



E108-GN Series User Manual

**GPS/BEIDOU MULTI-MODE SATELLITE POSITIONING AND
NAVIGATION MODULE**



CONTENTS

DISCLAIMER	7
1 PRODUCT OVERVIEW	8
1.1 PRODUCT INTRODUCTION	8
1.2 FEATURES	8
1.3 APPLICATION	8
2 SPECIFICATION AND PARAMETERS	9
2.1 WORKING PARAMETER	9
2.2 HARDWARE PARAMETER	9
2.3 GPS PERFORMANCE PARAMETER	9
3 SIZE AND PINS DEFINITION	11
3.1 E108-GN01 PINS DEFINITION	11
3.2 E108-GN02 PINS DEFINITION	12
3.3 E108-GN02D PINS DEFINITION	13
4 RECOMMENDED CIRCUIT DIAGRAM	14
4.1 E108-GN01	14
4.2 E108-GN02	14
4.3 E108-GN02D	15
5 HARDWARE DESIGN	16
6 E108-PRODUCT TEST	17
6.1 SERIAL PORT ASSISTANT	17
6.2 OPERATING NAVITRACK	18
7 COMMAND FORMAT	19
7.1 GKC INTERFACE DATA FORMAT	19
7.2 GKC COMMAND	19
7.2.1 Response message	19
7.2.2 System reboot	19
7.2.3 Erase auxiliary information	20
7.2.4 Low power mode	20
7.2.5 Message interval configuration	20
7.2.6 Periodic low power mode	20

7.2.7 Set star search mode	20
7.2.8 Save star search mode	21
7.2.9 Serial port parameter setting	21
7.2.10 Set NMEA output	22
7.2.11 GPD document delete	22
7.2.12 Set NMEA serial port parameter	22
7.2.13 PPS configuration	22
7.2.14 Query message interval	22
7.2.15 Return message interval	23
7.2.16 Set NMEA output frequency	23
7.2.17 Query NMEA output frequency	23
7.2.18 Return the NMEA output frequency	23
7.2.19 Set reference coordinates	23
7.2.20 Query Reference Coordinate System	24
7.2.21 Return Reference Coordinate System	24
7.2.22 Query RTC time	24
7.2.23 Return RTC time	24
7.2.24 Set the speed threshold	24
7.2.25 Set HDOP Threshold	25
7.2.26 Get HDOP Threshold	25
7.2.27 Version number query	25
7.2.28 Return the current version number	25
7.2.29 Set location and time information	25
7.2.30 Set positioning mode	26
7.2.31 Query ID information	26
7.2.32 Return ID information	26
7.3 SUPPORT NMEA0183 PROTOCOL	26
7.3.1 Statement identifier	26
7.3.2 GGA	27
7.3.3 GSA	27
7.3.4 GSV	28
7.3.6 VTG	29

8 GDP USER GUIDANCE **29**

8.1 GDP INTRODUCTION	29
8.2 HOW TO GET GPD DOC.	29
8.3 HOW TO USE GPD DOC.	29
8.4 HOW TO DELETE GPD DATA IN CHIPSET	29
8.5 THE EFFECT AFTER USING GPD	30
8.6 ASSISTED LOCALIZATION METHODS TO ACCELERATE GPD	30
8.7 GPD COMMUNICATION	30
8.7.1 Switch NMEA reception to BINARY reception mode	30
8.7.2 Send GPD first data block, wait for ACK response	31
8.7.3 Send the remaining data blocks in sequence and wait for the ACK response	31

8.7.4 Send GPD transfer end statement and wait for response	31
8.7.5 Switch BINARY reception to NMEA reception mode	31
9 FAQ	32
9.1 COMMUNICATION RANGE IS TOO SHORT	32
9.2 MODULE IS EASY TO DAMAGE	32
9.3 BER(BIT ERROR RATE) IS HIGH	32
10 WELDING INSTRUCTION	33
10.1 REFLOW SOLDERING TEMPERATURE	33
10.2 REFLOW SOLDERING CURVE	33
11 E108 SERIES	34
12 PACKING FOR BATCH ORDER	34
REVISION HISTORY	34
ABOUT US	35

Disclaimer

EBYTE reserves all rights to this document and the information contained herein. Products, names, logos and designs described herein may in whole or in part be subject to intellectual property rights. Reproduction, use, modification or disclosure to third parties of this document or any part thereof without the express permission of EBYTE is strictly prohibited.

The information contained herein is provided “as is” and EBYTE assumes no liability for the use of the information. No warranty, either express or implied, is given, including but not limited, with respect to the accuracy, correctness, reliability and fitness for a particular purpose of the information. This document may be revised by EBYTE at any time. For most recent documents, visit www.cdebyte.com.

1 Product overview

1.1 Product introduction

E108-GN series is a high-performance, high-integration, low-power, low-cost multi-mode satellite positioning and navigation module, for BDS/GPS/GLONASS, small size, low power consumption, can be used for car navigation, smart wear, In the application of GNSS positioning such as drones, it also provides software and hardware interfaces compatible with other module manufacturers, which greatly reduces the user's development cycle.

The module adopts the integrated design of RF baseband, integrates DC/DC, LDO, RF front-end, low-power application processor, RAM, Flash storage, RTC and power management, etc. It supports crystal oscillator or external pin clock input, which can be input through a coin cell battery or farad capacitor powers the RTC and backup RAM to reduce the time to first fix. It also supports a variety of ways to connect with other peripherals, and supports UART and GPIO interfaces. If you need I2C and SPI interfaces, please contact customer service for customization.

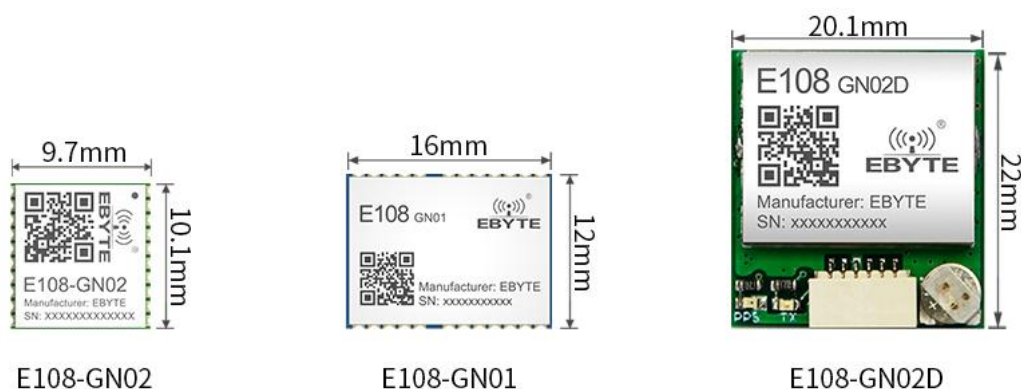

1.2 Features

- Support BDS/GPS/GLONASS multi-system joint positioning and single-system independent positioning;
- D-GNSS differential positioning, A-GNSS assisted positioning, ephemeris prediction, DR integrated navigation application, the fastest data update rate 10Hz;
- 32-bit application processor, the highest frequency is 133MHz, supports dynamic frequency adjustment;
- Support PPS output;
- Built-in reset controller;
- UART, GPIO interface;
- RTC: Support 32.768KHz±20ppm crystal oscillator, 1.1VRTC clock output, support external signal wake-up;
- Output format: support NMEA0183V4.1 and previous versions, the maximum fixed update frequency can reach 10Hz;
- High sensitivity: capture cold start -149dBm, hot start -162dBm, tracking -166dBm;
- The software and hardware are compatible with those of other manufacturers, which greatly reduces the user's development cycle;

1.3 Application

- Vehicle positioning and navigation equipment;
- Wearable devices, such as GPS trackers, etc.;
- UAV positioning, industrial computer, etc.;
- Industry equipment that needs GNSS positioning or navigation;

2 Specification and parameters

2.1 Working parameter

Main parameters		Performance			Remarks
		Min.	Typ.	Max.	
Working voltage (V)		3.0	5.0	5.5	≥5.0V can guarantee the output power
Communication level (V)			2.8		Risk of burnout with 5V TTL
Working temperature (°C)		-35	-	+85	Industrial grade design
Working frequency band (MHz)		2400	-	2518	Support ISM band
Power consumption	Emission current (mA)		35		Instantaneous power consumption
	Receive current (mA)		20		
	Sleep current (μA)		120		Software shutdown

2.2 Hardware parameter

Main parameters	Description	Remarks
Baud rate (bps)	9600-921600	Default 9600
Data bits	8bit	
Stop bit	1	
Communication Interface	UART (TXD/RXD) or GPIO	
Packaging method	Half hole	SMT
Dimensions	See Chapter 3 Pin Definitions	
Antenna interface	Stamp hole	
Letter of agreement	Support NMEA0183 V4.1 and previous versions	Maximum fixed update frequency up to 10Hz
Supported positioning systems	BDS/GPS/GLONASS	

2.3 GPS performance parameter

Category	Index Item	Typical Value	Unit
Positioning time (Test Condition 1)	Cold start	27.5	s
	Hot Start	<1	s
	Recapture	<1	s
Positioning time (Test Condition 1)	A-GNSS	<10	s
Sensitivity (Test Condition 2)	Cold start	-149	dBm
	Hot Start	-162	dBm
	Recapture	-164	dBm

	Track	-166	dBm
Precision (Test Condition 3)	Horizontal positioning accuracy	2.5	m
	High positioning accuracy	3.5	m
	Speed positioning accuracy	0.1	m/s
	Timing accuracy	30	ns
Power consumption (Test Condition 4)	Capture current	35	mA
	Tracking current	20	mA
Operating temperature	--	-35°C-85°C	--
Storage temperature	--	-55°C-100°C	--
Humidity	--	5%-95%RH(No condensation)	--

Note: The above results are GPS/Beidou dual-mode working mode; the highest altitude can reach 18,000 meters, but the accuracy of the data will be deviated after more than 10,000 meters.

[Test condition 1]: The number of receiving satellites is greater than 6, the signal strength of all satellites is -130dBm, the average value is obtained for 10 tests, and the positioning error is within 10 meters.

[Test condition 2]: The noise figure of the external LNA is 0.8, the number of receiving satellites is greater than 6, and the received signal strength value under the condition of locking within five minutes or not losing the lock.

[Test condition 3]: Open and unobstructed environment, 24 hours of continuous power-on test, 50% CEP.

[Test condition 4]: The number of receiving satellites is greater than 6, and the signal strength of all satellites is -130dBm.

3 Size and pins definition

3.1 E108-GN01 pins definition

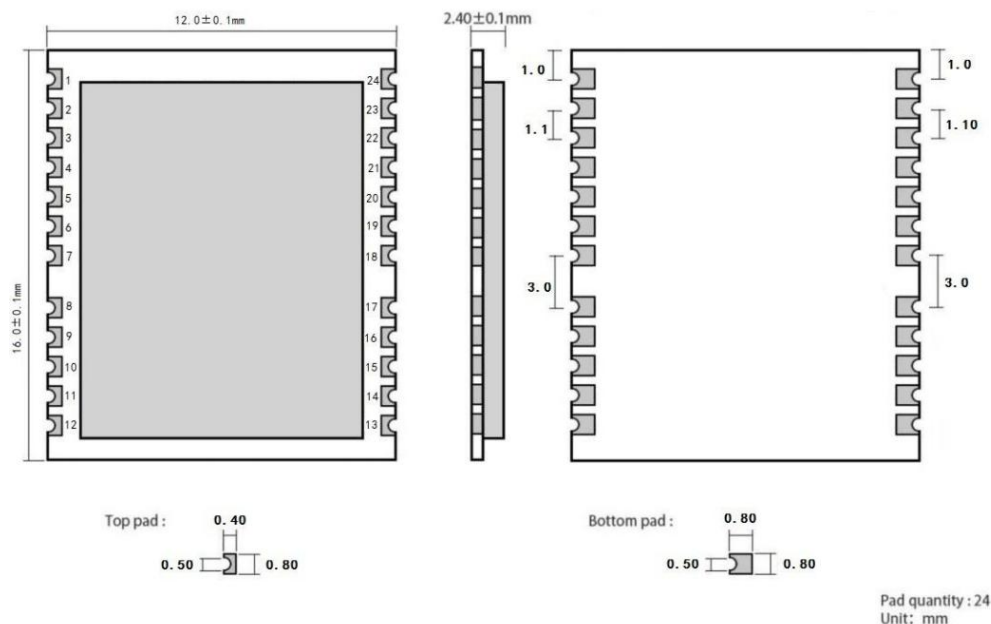

No.	Name	Direction	Function
1	NC	Remained pins	
2	NC	Remained pins	
3	1PPS	Location indicator	If the positioning is successful, a square wave will be output
4	EINT3	External Interrupt 3	Default: pull-down, 8mA drive current
5	FORCE_ON	Sleep wake-up pin	When the module enters low power consumption, pull this pin high to exit the low power consumption mode (the level voltage of this pin is 1.1V, if the level of the control pin is not 11V, it needs to divide the voltage)
6	EINT0	External interrupt 0	Default: pull-down, 8mA drive current
7	NC	Remained pins	
8	RSTN	Reset pin	Pull high by default, pull low to reset.
9	VCC_RF	RF power output	Power supply for active antenna (this RF output power supply voltage is equal to VCC)
10	GND	Module ground	
11	RF IN	RF input	
12	GND	Module ground	
13	GND	Module ground	
14	NC	Remained pins	
15	NC	Remained pins	
16	RSTN	Reset pin	Pull high by default, pull low to reset
17	EINT1	External Interrupt 1	Default: pull-down, 8mA drive current
18	TX1	UART1 output	(Reserved, 28V level)
19	RX1	UART1 input	(Reserved, 28V level)
20	TXD	UART output	(AT port, 28V level)

21	RXD	UART input	(AT port, 28V level)
22	VBKP	RTC power input	The RTC power supply must be powered, the module
23	VCC	Module power	The module startup voltage needs to provide a stable voltage of 4.2V. If the startup voltage is lower than this value, it may cause no printout of the serial port. After startup, it can be reduced to normal 3.3V voltage operation.
24	GND	Module ground	

3.2 E108-GN02 pins definition

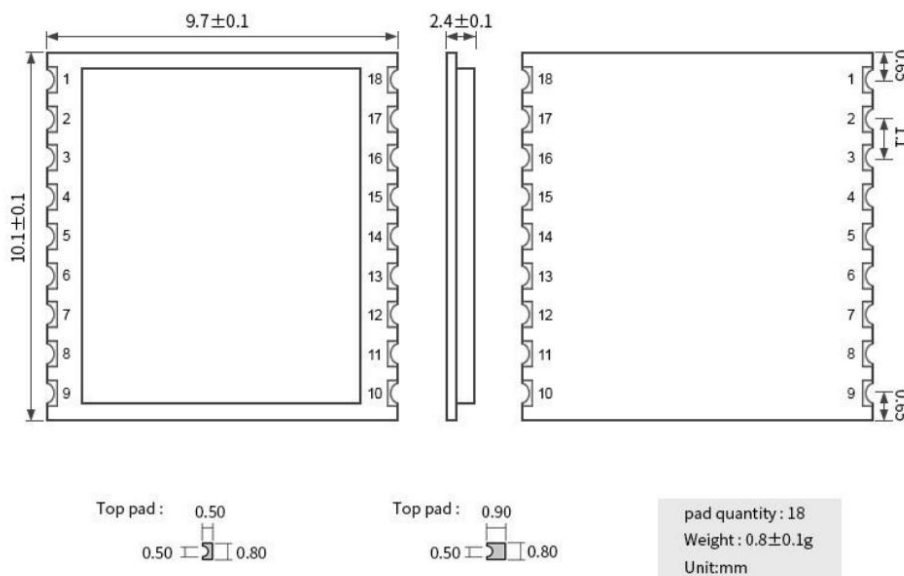

No.	Name	Direction	Function
1	GND	Module power ground wire	
2	TXD	Output	UART output (2.8V level)
3	RXD	Enter	UART input (2.8V level)
4	1PPS	Second pulse output	User can set frequency, duration, etc. by command
5	FORCE_ON	Sleep wake-up pin	When the module enters the ultra-low power consumption, pull this pin high to exit the ultra-low power consumption mode (this pin is powered)
6	VBKP	RTC power input	The voltage is 11V, if the control pin level is not 11V, it needs to divide the voltage)
7	NC	Remained pins	
8	VCC	Module power	(2.8V-4.2V)
9	RSTN	Reset pin	Pull high by default, pull low to reset;
10	GND	Module ground	
11	RF IN	RF input	
12	GND	Module ground	
13	ANTON	External	External LNA or active antenna power control pin 28V level:
14	VCCRF	RF power output	Power supply for external active antenna (this VCC RF output voltage is equal to VCC)
15	NC	Remained pins	
16	NC	Remained pins	
17	NC	Remained pins	
18	NC	Remained pins	

3.3 E108-GN02D pins definition

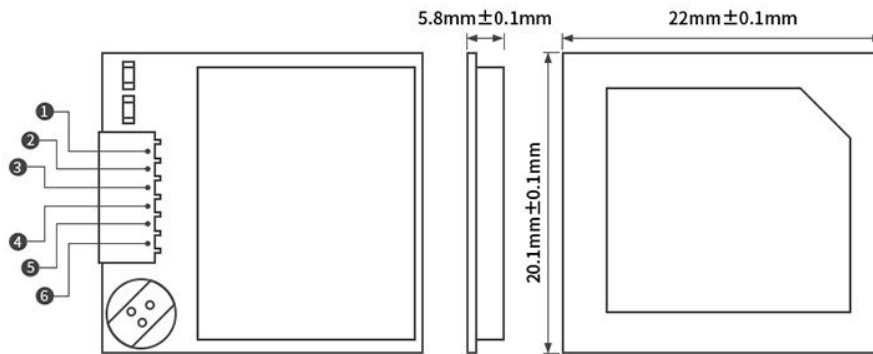

No.	Name	Direction	Function
1	CE	Power enable terminal	Power enable terminal, can be pulled low to enter low power mode (default is high)
2	1PPS	1PPS output	1PPS output, the user can set the frequency, duration, etc. through commands
3	GND		Module power ground wire
4	TXD	output	UART output (2.8V level)
5	RXD	enter	UART input (2.8V level)
6	VCC		Module power supply (3~5.5V)

4 Recommended circuit diagram

4.1 E108-GN01

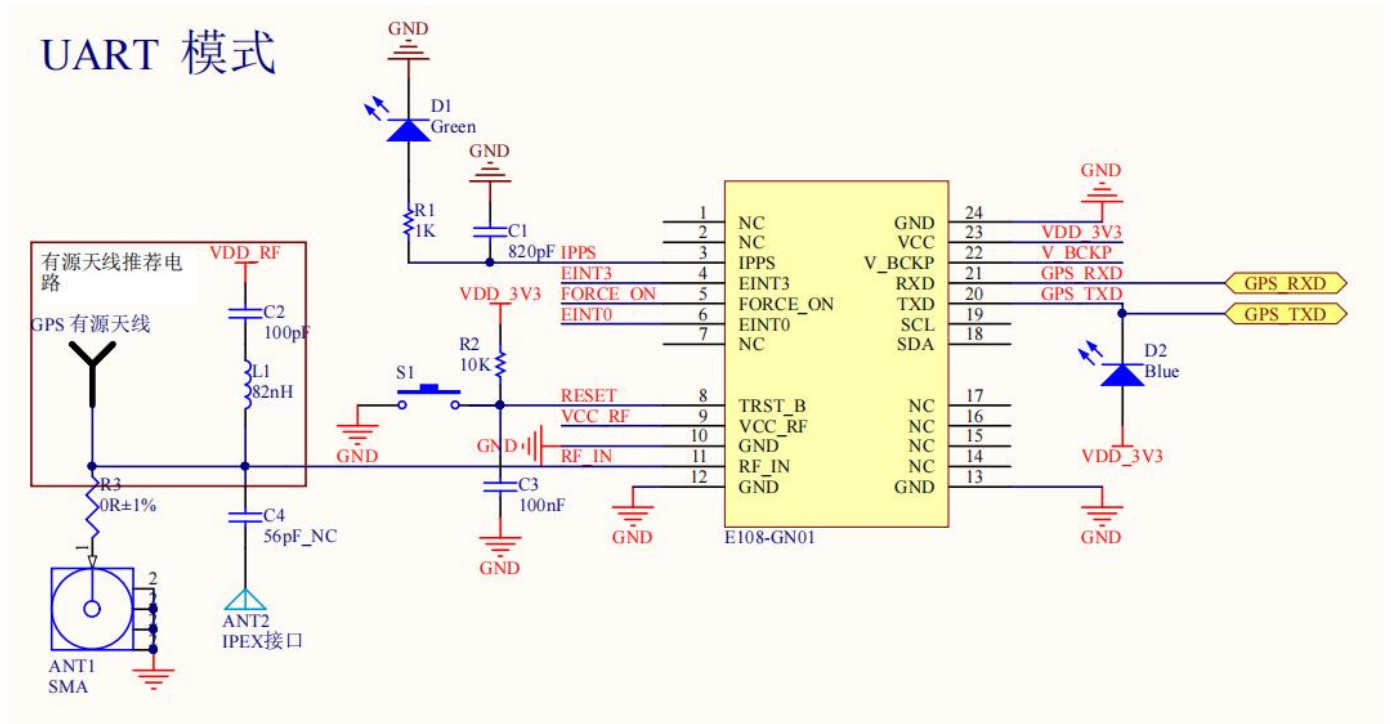

4.2 E108-GN02

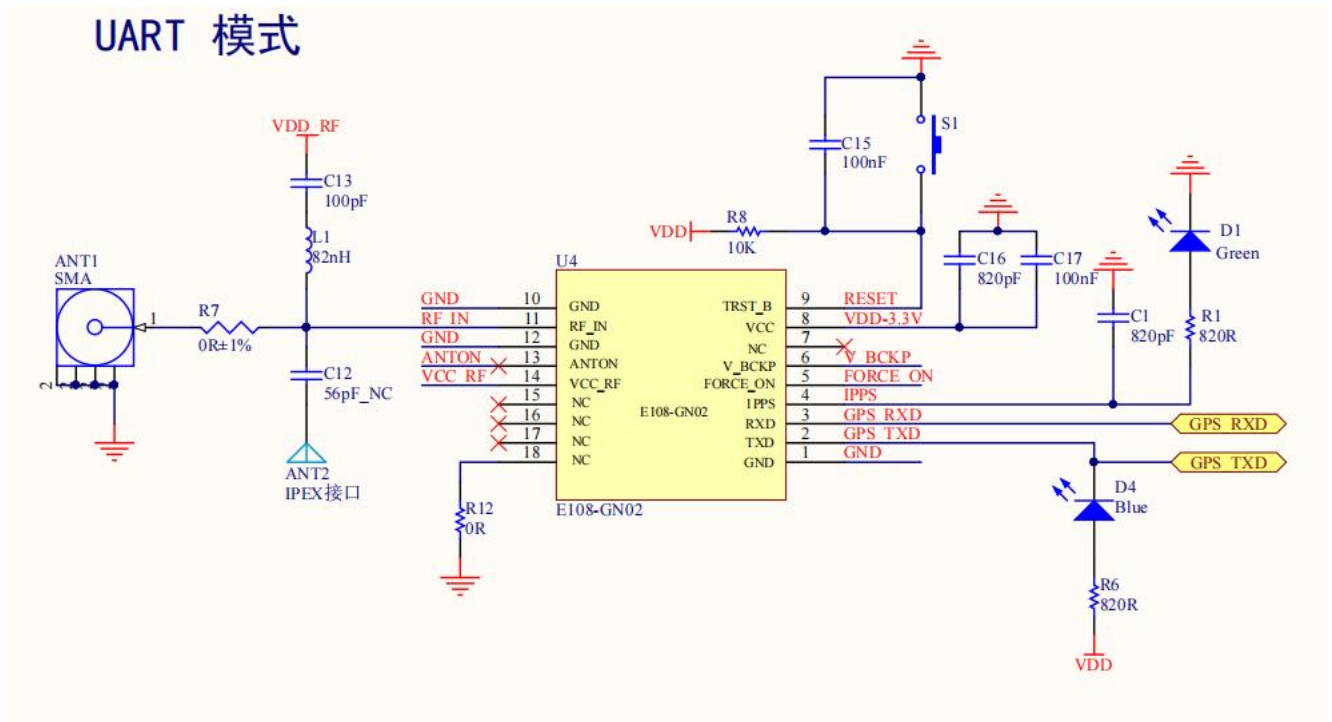

4.3 E108-GN02D

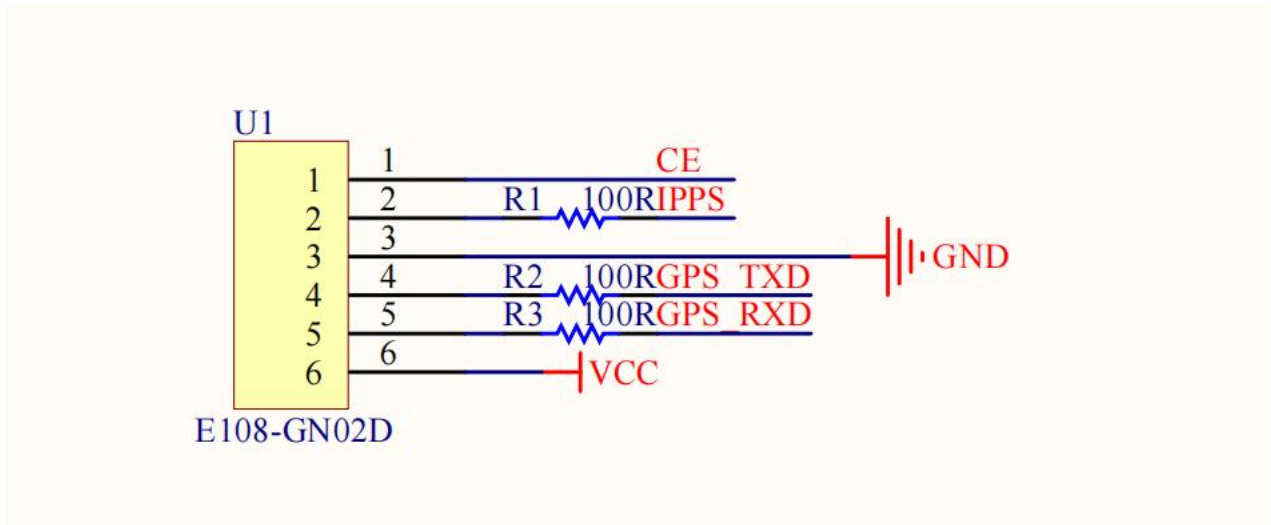

5 Hardware design

- For the schematic design of the module, you can directly refer to the E108-GN01-TB-SCH in the data package;
- It is recommended to use a DC regulated power supply to power the module, the power supply ripple should not exceed 50mV, and the module must be grounded reliably;
- Please pay attention to the correct connection of the positive and negative poles of the power supply, such as reverse connection may cause permanent damage to the module;
- Please check the power supply to ensure that it is between the recommended power supply voltages. If it exceeds the maximum value, the module will be permanently damaged;
- The serial port TXD and RXD are LVTTTL level, if connected with PC, it needs to be converted by RS232 level. Users can use this serial port to receive positioning information data and software upgrades;
- This module is a temperature-sensitive device, and its performance will be degraded due to severe temperature changes. Try to keep away from high-temperature airflow and high-power heating devices during use;
- When designing the power supply circuit for the module, it is often recommended to reserve more than 30% of the margin, so that the whole machine can work stably for a long time;
- The module should be kept away from parts with large electromagnetic interference such as power supply, transformer, and high-frequency wiring as far as possible. High-frequency digital wiring, high-frequency analog wiring, and power wiring must be avoided under the module.
- Assuming that the module is soldered on the TopLayer, the TopLayer in the contact part of the module is covered with ground copper (all copper and well grounded), which must be close to the digital part of the module and routed on the BottomLayer;
- Assuming that the module is soldered or placed on the TopLayer, it is also wrong to arbitrarily route wires on the BottomLayer or other layers, which will affect the stray and receiving sensitivity of the module to varying degrees;
- Assuming that there are devices with large electromagnetic interference around the module, it will also greatly affect the performance of the module. It is recommended to stay away from the module according to the intensity of the interference. If the situation allows, appropriate isolation and shielding can be done;
- Assuming that there are traces with large electromagnetic interference around the module (high-frequency digital, high-frequency analog, power traces), it will also greatly affect the performance of the module. It is recommended to stay away from the module according to the intensity of the interference. Proper isolation and shielding;
- The antenna installation structure has a great influence on the performance of the module, make sure that the antenna is exposed and preferably vertically upward;
- When the module is installed inside the casing, a high-quality antenna extension cable can be used to extend the antenna to the outside of the casing;
- The antenna must not be installed inside the metal shell, which will greatly weaken the transmission distance.

6 E108-Product test

6.1 Serial port assistant

Test based on E108-GN01-TB, if there is no test board, you can refer to the backplane schematic diagram in the data package (this test content is also applicable to E108-GN02/D).

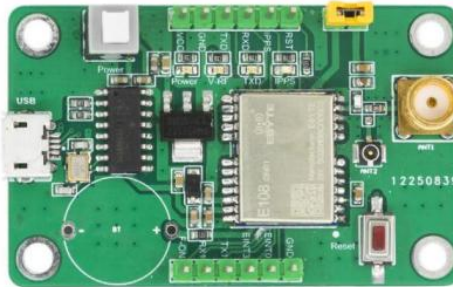

1. After connecting the GPS antenna, connect to the computer through the USB cable at the same time, there is a USB port on the opposite side of the antenna of the board, and then press the switch button to turn it on.
2. Note that when using an active antenna, the two pins of RF_POWER need to be short-circuited with jumpers.
3. You can open the serial port assistant to view the data reported by the serial port, or use our naviTrack to view it.

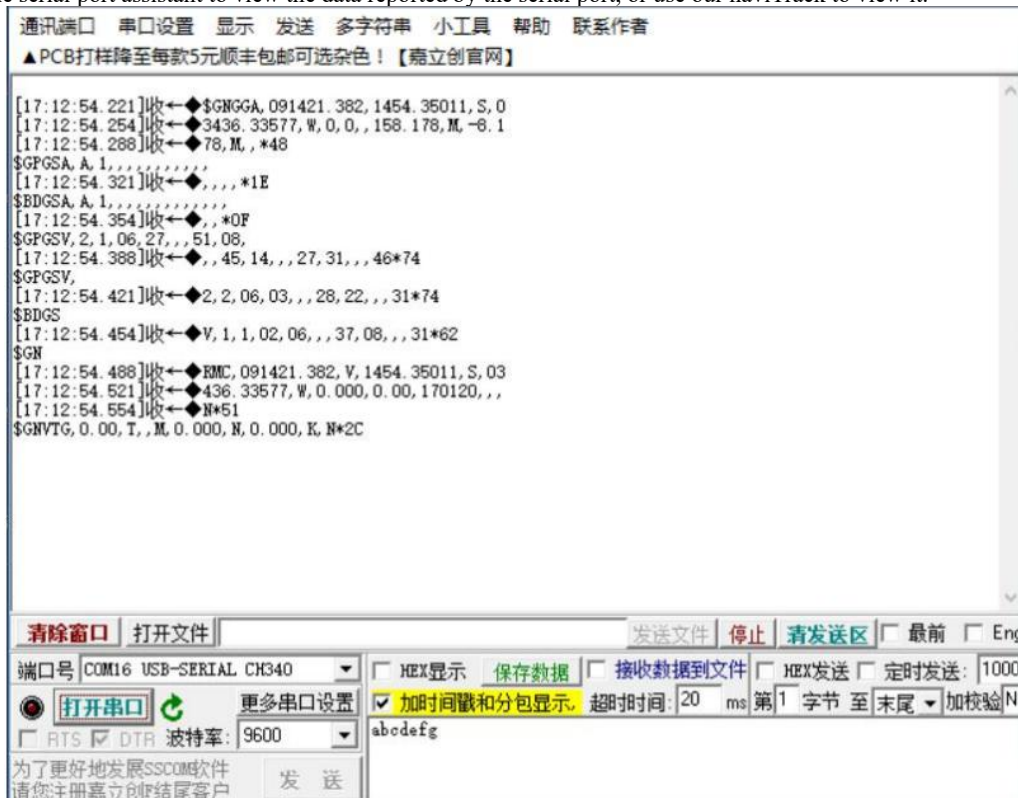

When the baud rate is set to 9600bps, data will be reported all the time after opening the serial port. The common output format is as follows:
 GGA: time, location, number of satellites;
 GSA: GPS receiver operation mode, satellites used for positioning, DOP value, positioning status;
 GSV: visible GPS satellite information, elevation angle, azimuth angle, signal-to-noise ratio;
 RMC: time, date, position, speed;
 VTG: ground speed information (for details, please refer to the NMEA0183 protocol);

6.2 Operating naviTrack

For the convenience of use, we recommend using the exclusive tool TaviTrack for debugging. For details, see the "naviTrack User Manual".

1. Run naviTrack with administrator privileges and run the following page:
2. Select the corresponding com port and click connect. After the connection is successful, you can see the reported data in the NMEA window.
Note: For the detailed meaning, please refer to the description in Section 3 NMEA0183 protocol.
3. After the positioning is successful, the latitude and longitude information can be obtained in the \$GPRMC field reported by the serial port.
For more detailed tool usage information, please refer to the tool manual in the kit.

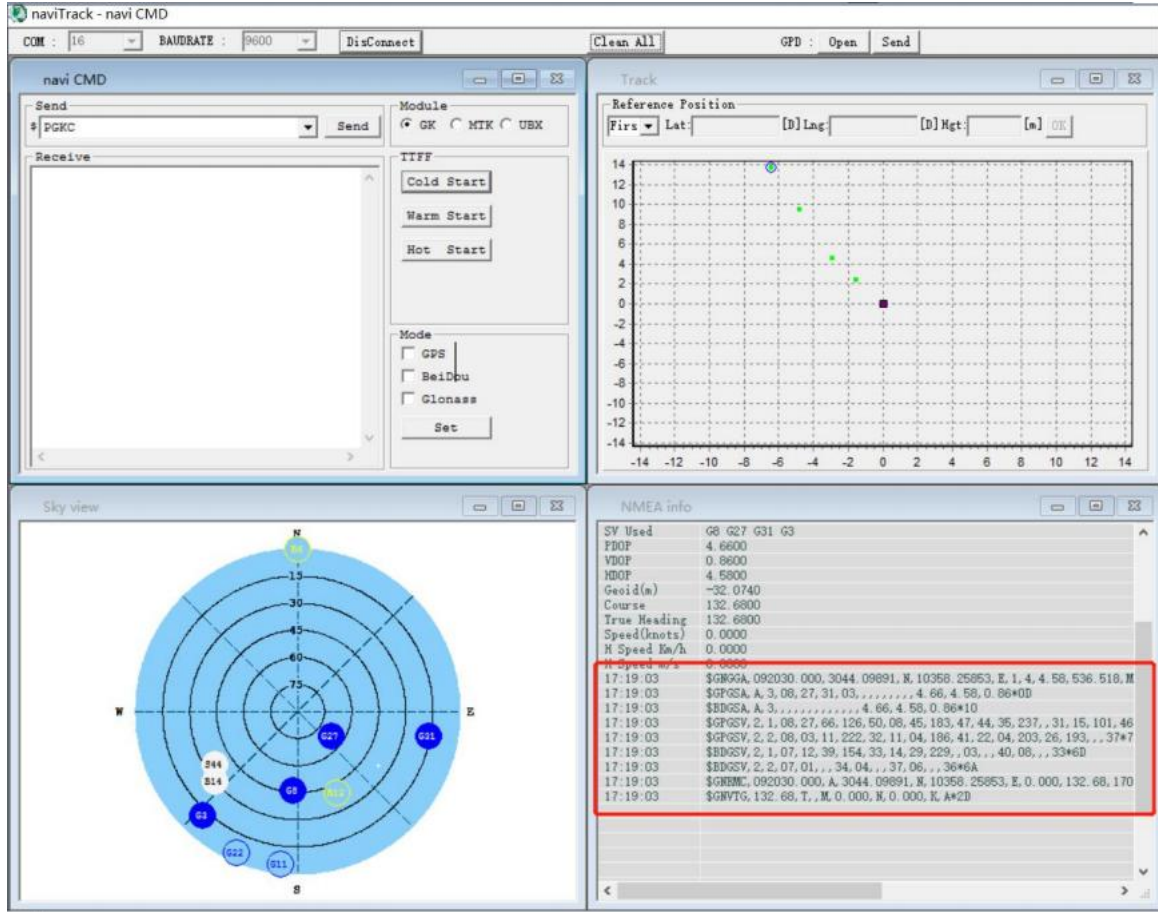

7 Command format

7.1 GKC interface data format

The Goke Command (GKC) interface is the interface for interaction between the user and GK9501. Its command format is as follows:

\$PGKC	Command	Arguments	*	CheckSum	CR	LF
--------	---------	-----------	---	----------	----	----

7.2 GKC command

Name	Description	Remarks
Command	Indicates the command number sent	The reference value refers to the next GKC instruction
Arguments	Indicates the parameters required to send the command, the parameters can be multiple, and different commands correspond to different data	The reference value refers to the next GKC instruction
*	end of data sign	
CheckSum	Checksum data for the entire command	CheckSum value is in the whole command from PGKC to
CR, LF	end of package sign	*The previous argument XOR value, such as "\$PGKC030,3,1", its check value is the XOR value of "PGKC030,3,1", its XOR value is 2E

7.2. Response message

Command: 001

reply message

Response to the message processing result sent by the other party

Arguments:

Arg1: the command of the message to which this message responds

Arg2:

"1", the received message is not supported

"2", valid message, but incorrect execution

"3", valid message, and executed correctly

Example:

Send a single GPS command: \$PGKC115,1,0,0,0*2B<CR><LF>

Reply message: \$PGKC001,115,3,1,0,0,0,1*28<CR><LF>

7.2.2 System reboot

Command: 030

System reboot command

Arguments:

Arg1:

"1", warm start

"2", warm start

"3", cold start

"4", full cold start

Arg2:

"1", software restart

"2", hardware restart

"3", clear nvram, keep flash reboot

Example:

Full cold start command: \$PGKC030,4,2*2A<CR><LF> Hot start command: \$PGKC030,1,1*2C<CR><LF>

Remarks: Arg2 is set to 1 for both warm start and warm start, and Arg2 is 1, 2, and 3 for full cold start.

In general, the cold start is the full cold start mode, Arg1 is set to 4, Arg2 is set to 2, and the hardware boot mode is not used.

7.2.3 Erase auxiliary information

Command: 040

Erase auxiliary information in flash Arguments: None

Example:

\$PGKC040*2B<CR><LF>

7.2.4 Low power mode

Command: 051

Enter standby low power mode

Arguments:

Arg1: "0", stop mode

Example:

\$PGKC051,0*37<CR><LF>

This command can be woken up by sending any command, invalid commands can also be used, the hardware can be woken up by plugging and unplugging the serial port, and the original low-power command can be sent directly.

7.2.5 Message interval configuration

Command: 101

Configure the interval for outputting NMEA messages (unit: ms)

Arguments:

Arg1: 100-10000

Example:

\$PGKC101,1000*02<CR><LF>

The command set is to output NMEA data every 1000ms, which is 1s.

Remarks: When setting the message interval output above 2HZ, first increase the baud rate to above 115200 to ensure high-frequency NMEA message output. This command is not saved in Flash, and will be restored to the original NMEA output frequency after power failure; baud rate Modification requires firmware version 3.0 or above to support configuration, and NMEA frequency does not support saving.

7.2.6 Periodic low power mode

Command: 105

Enter periodic low power mode

Arguments:

Arg1:

"0", normal operating mode

"1", period ultra-low power tracking mode

"4", directly enter ultra-low power tracking mode

"8", low power consumption mode, you can wake up by sending commands through the serial port

Arg2:

Run time (ms), this parameter has effect in periodic mode with Arg1 = 1.

Arg3:

Sleep time (milliseconds), in periodic mode where Arg1 is 1, this parameter works.

Example:

\$PGKC105,8*3F<CR><LF>

\$PGKC105,1,5000,8000*3B<CR><LF>

Note: In low-power mode, the CPU will sleep and can be woken up through the serial port; in ultra-low-power tracking mode, when the CPU is powered off, it will automatically wake up periodically for positioning output.

7.2.7 Set star search mode

Command: 115

Set star search mode

Arguments:

Arg1:

“1”, GPS on

“0”, GPS off

Arg2:

“1”, Glonass on

“0”, Glonass off

Arg3:

“1”, Beidou on

“0”, Beidou off

Arg4:

“1”, Galileo on

“0”, Galileo off

Example:

To set the star search mode to single GPS mode, the command is as follows:

```
$PGKC115,1,0,0,0*2B<CR><LF>
```

Note: Although the single Galileo mode command \$PGKC115,0,0,0,1*2B can be sent successfully, the current GK9501 firmware does not support Galileo star search mode.

7.2.8 Save star search mode

Command: 121

Set star search mode, save it to flash

Arguments:

Arg1:

“1”, GPS on

“0”, GPS off

Arg2:

“1”, Glonass on

“0”, Glonass off

Arg3:

“1”, Beidou on

“0”, Beidou off

Arg4:

“1”, Galileo on

“0”, Galileo off

Example:

Set star search mode to single GPS mode

```
$PGKC121,1,0,0,0*2C<CR><LF>
```

Remarks: The difference between Command115 and 121 commands is that the 115 command will not be saved in flash after setting, the star search mode set will disappear after restarting, the 121 command setting will be saved in flash, and the star search mode set after restarting will be retained. Neither 115 nor 121 support Galilean galaxies.

7.2.9 Serial port parameter setting

Command: 146

Set the serial port input and output format and baud rate

Arguments:

Arg1:

”3”, NMEA format

Arg2:

“3”, NMEA format

Arg3:

9600, 19200, 38400, 57600, 115200.....921600,

Example:

```
$PGKC146, 3, 3, 9600*0F<CR><LF>
```

7.2.10 Set NMEA output

Command: 147
 Set NMEA output baud rate;
 Arguments:
 Arg1:
 9600, 19200, 38400, 57600, 115200.....921600,
 Example:
 \$PGKC147,115200*06<CR><LF>

7.2.11 GPD document delete

Command: 047
 Delete GPD doc in flash
 Arguments: None
 Example:
 \$PGKC047*2C<CR><LF>

7.2.12 Set NMEA serial port parameter

Command: 149
 Set NMEA serial port parameter
 Arguments:
 Arg1:
 "0", NMEA data
 "1", Binary data
 Arg2:9600, 19200, 38400, 57600, 115200.....921600,
 Example:
 \$PGKC149, 0, 38400*2C<CR><LF>
 \$PGKC149, 1, 115200*15<CR><LF>

Remarks: This command is usually used in AGPS to load GPD files into Flash; the baud rate modification requires firmware version 3.0 or above to support configuration;

7.2.13 PPS configuration

Command: 161
 PPS configuration
 Arguments:
 Arg1:
 "0", turn off PPS output
 "1", first time fix
 "2", 3D fix
 "3", 2D/3D fix
 "4", always on
 Arg2:
 PPS pulse width (ms)
 Arg3:
 PPS pulse period (ms)
 Example:
 \$PGKC161, 2, 500, 2000*0<CR><LF>
 Note: The maximum pulse width of PPS is 998ms, the minimum is 1ms, and the minimum range of pulse period is 1000ms.

7.2.14 Query message interval

Command: 201
 Query interval for NMEA messagesArguments: None

Example:
\$PGKC201*2C<CR><LF>

7.2.15 Return message interval

Command: 202
Interval for returning NMEA messages (response to 201 command)
Arguments: None
Example:
\$PGKC202, 1000, 0, 0, 0, 0, 0, 0, 0*02<CR><LF>

7.2.16 Set NMEA output frequency

Command: 242
Set NMEA sentence output frequency
Arguments:
Arg1: GLL
Arg2: RMC
Arg3: VTG
Arg4: GGA
Arg5: GSA
Arg6: GSV
Arg7: GRS
Arg8: GST
Arg9~Arg21: Remain
Example:
\$PGKC242,1,1,1,1,1,1,0,0,0,0,0,0,0,0,0,0,0,0*37 <CR><LF>

7.2.17 Query NMEA output frequency

Command: 243
Query NMEA sentence output frequency
Arguments: None
Example:
\$PGKC243*2A<CR><LF>

7.2.18 Return the NMEA output frequency

Command: 244
Return the NMEA sentence output frequency (in response to the 243 command)
Arguments:
Args: Refer to 242 Commands
Example:
\$PGKC244,1,1,1,1,1,1,0,0,0,0,0,0,0,0,0,0,0,0*31<CR><LF>

7.2.19 Set reference coordinates

Command: 269
Set reference coordinates
Arguments:
Arg1:

“0”, WGS84
 Example:
 \$PGKC269,0*3E<CR><LF>

7.2.20 Query Reference Coordinate System

Command: 270
 Query Reference Coordinate System
 Arguments: None
 Example:
 \$PGKC270*2A<CR><LF>

7.2.21 Return Reference Coordinate System

Command: 271
 Return to the reference frame (response to command 270)
 Arguments:
 Arg1: Refer to 269 Commands
 Example:
 \$PGKC271, 0*37<CR><LF>

7.2.22 Query RTC time

Command: 279
 Query RTC time
 Arguments: None
 Example:
 \$PGKC279*23<CR><LF>

7.2.23 Return RTC time

Command: 280
 Return RTC time (response to command 279)
 Arguments:
 Args:
 Refer to 278 Commands
 Example:
 \$PGKC280,2017,3,15,12,0,0*15<CR><LF>

7.2.24 Set the speed threshold

Command: 284
 Set the speed threshold, when the speed is lower than the threshold, the output speed is 0
 Arguments:
 Arg1:
 Threshold value
 Example:
 \$PGKC284,0.5*26<CR><LF>

Note: The speed unit is m/s. If the speed is set to a negative number, the command will not take effect, and the original speed threshold output will be maintained.

7.2.25 Set HDOP Threshold

Command: 356

Set the HDOP threshold, when the actual HDOP is greater than the threshold, no positioning

Arguments:

Arg1: Threshold value

Example:

```
$PGKC356,0.7*2A<CR><LF>639
```

7.2.26 Get HDOP Threshold

Command: 357

Get HDOP Threshold

Arguments: None

Example:

```
$PGKC357*2E<CR><LF>
```

7.2.27 Version number query

Command: 462

Query the version number of the current software

Arguments: None

Example:

```
$PGKC462*2F<CR><LF>
```

7.2.28 Return the current version number

Command: 463

Return the version number of the current software (responds to the 462 command)

Arguments: None

Example:

```
$PGKC463,GK9501_2.0_Aug 10 2020,GOKE microsemi *3F<CR><LF>
```

7.2.29 Set location and time information

Command: 639

Set approximate location and time information for faster positioning

Arguments:

Arg1: Latitude, eg: 28.166450

Arg2: Longitude, eg: 120.389700

Arg3: height, eg: 0

Arg4: Year

Arg5: month

Arg6: Day

Arg7: Hour, time is UTC time

Arg8: points

Arg9: seconds

Example:

```
$PGKC639,28.166450,120.389700,0,2017,3,15,12,0,0*33<CR><LF>
```

Remarks: Among them, the unit of latitude and longitude is degrees, and the height is meters

7.2.30 Set positioning mode

Command: 786
 Set positioning mode
 Arguments:
 Arg1:
 "0", normal mode
 "1", fitness mode for walking and jogging
 "2", aero mode, suitable for high-speed sports mode
 "3", balloon mode, for elevation mode
 Example:
 \$PGKC786,1*3B<CR><LF>

7.2.31 Query ID information

Command: 490
 Query the current FLASH unique ID information.
 Arguments: None
 Example:
 \$PGKC490*22<CR><LF>

7.2.32 Return ID information

Command: 491
 Return the current FLASH unique ID information (response to 490 command)
 Arguments:
 Arg1:
 ManufacturerID and DeviceID in Flash, For example: 1351
 Arg2:
 UniqueID1, For example: 32334C30,AE000230
 Arg3:
 UniqueID2, For example: FF507900,FFFFFFFF
 Example:
 \$PGKC491,1351,32334C30,AE000230,FF507900,FFFFFFFF,*5E<CR><LF>

7.3 Support NMEA0183 protocol

GK9501 supports NMEA0183 V4.1 protocol and is compatible with previous versions. For more information about NMEA0183 V4.1, please refer to the official NMEA 0183 V4.1 document. Common output formats are as follows:

- GGA: time, location, number of satellites
- GSA: GPS receiver operating mode, satellites used for positioning, DOP value, positioning status
- GSV: visible GPS satellite information, elevation, azimuth, signal-to-noise ratio
- RMC: time, date, position, speed
- VTG: ground speed information

7.3.1 Statement identifier

Statement identifier	Description
BD	BDS,Beidou second generation satellite system
GP	GPS
GL	GLONASS
GA	Galileo
GN	GNSS,Global Navigation Satellite System

7.3.2 GGA

\$--GGA,hhmmss.ss,llll.ll,a,yyyy.yy,a,x,xx,x.x,x.x,M,x.x,M,x.x,xxxx*hh

Sample data: \$GPGGA,065545.789,2109.9551,N,12023.4047,E,1,9,0.85,18.1,M,8.0,M,,*5E

Name	Example	Unit	Description
message ID	\$GPGGA		GGA protocol header
UTC time	065545.789		hhmmss.sss
latitude	2109.9551		ddmm.mmmm
N/S indication	N		N=North, S=South
longitude	12023.4047		dddmm.mmmm
E/W indication	E		W=west, E=east
Positioning instructions			0: not located 1: SPS mode, positioning is valid 2: Differential, SPS mode, positioning is valid 3: PPS mode, positioning is valid
number of satellites	9		Range 0 to 12
HDOP	0.85		Horizontal accuracy
MSL amplitude	18.1	M	
unit	M	M	
the earth	-2.2	M	
unit	M		-
differential time	8.0	S	Invalid when there is no DGPS
Differential ID	0000		
checksum	*5E		
<CR><LF>			End of message

7.3.3 GSA

\$--GSA,a,a,x*x*hh

Sample data: \$GPGSA,A,3,10,24,12,32,25,21,15,20,31,,,,,1.25,0.85,0.91*04

Name	Example	Unit	Description
message ID	\$GPGS		GSA protocol header
Mode 1	A		M>manual, force in 2D or 3D mode
Mode 2	3		A=Auto
satellite use	10		1: Positioning invalid; 2: 2D positioning; 3: 3D positioning
satellite use	24		Channel 1
satellite use	12		Channel 2
satellite use	32		Channel 3
satellite use	25		Channel 4
satellite use	21		Channel 5
satellite use	15		Channel 6
satellite use	20		Channel 7
...
satellite use			Channel 12
PDOP	1.25		Position accuracy
HDOP	0.85		Horizontal accuracy
VDOP	0.91		vertical accuracy
checksum	*04		
<CR><LF>			End of message

7.3.4 GSV

\$--GSV,x,x,x,x,x,x,x,x...*hh

Sample data:

\$GPGSV,3,1,12,14,75,001,31,32,67,111,38,31,57,331,33,26,47,221,20*73
 \$GPGSV,3,2,12,25,38,041,29,29,30,097,32,193,26,176,35,22,23,301,30*47
 \$GPGSV,3,3,12,10,20,185,28,44,20,250,,16,17,217,21,03,14,315,*7D

Name	Example	Unit	Description
message ID	\$GPGSV		GSV protocol header
number of messages	3		Range 1 to 3
message number	1		Range 1 to 3
number of satellites	12		
Satellite ID	14		Range 1 to 32
Elevation angle	75	Degree	up to 90°
Azimuth	001	Degree	Range 0 to 359°
Carrier-to-Noise Ratio (C/No)	31	dBHz	Range 0 to 99, null if no trace
Satellite ID	32		Range 1 to 32
Elevation angle	67	Degree	up to 90°
Azimuth	111	Degree	Range 0 to 359°
Carrier-to-Noise Ratio (C/No)	38	dBHz	Range 0 to 99, null if no trace
Satellite ID	31		Range 1 to 32
Elevation angle	57	Degree	up to 90°
Azimuth	331	Degree	Range 0 to 359°
Carrier-to-Noise Ratio (C/No)	33	dBHz	Range 0 to 99, null if no trace
Satellite ID	26		Range 1 to 32
Elevation angle	47	Degree	up to 90°
Azimuth	221	Degree	Range 0 to 359°
Carrier-to-Noise Ratio (C/No)	20	dBHz	Range 0 to 99, null if no trace
checksum	*73		
<CR><LF>			End of message

7.3.5 RMC

\$--RMC,hhmmss.ss,A,llll.ll,a,yyyyy.yy,a,x.x,x.x,xxxx,x.x,a*hh example data:

\$GPRMC,100646.000,A,3109.9704,N,12123.4219,E,0.257,335.62,291216,,A*59

Name	Example	Unit	Description
message ID	\$GPRMC		RMC protocol header
UTC time	100646.000		hhmmss.ss
state	A		A=Data valid; V=Data invalid
latitude	2109.9704		ddmm.mmmm
N/S indication	N		N=North, S=South
longitude	11123.4219		dddmm.mmmm
E/W indication	E		W=west, E=east
ground speed	0.257	Knot (section)	
position	335.62	degree	
date	291216		ddmmyy
Magnetic variable			-
checksum	*59		
<CR><LF>			End of message

7.3.6 VTG

\$--VTG,x.x,T,x.x,M,x.x,N,x.x,K*hh

Sample data: \$GPVTG,335.62,T,,M,0.257,N,0.477,K,A*38

Name	Example	Unit	Description
message ID	\$GPVTG		VTG protocol header
position	335.62	degree	
refer to	T		True
position	335.62	degree	
refer to	M		Magnetic
speed	0.257	Knot (section)	
unit	N		section
speed	0.477	km/h	
unit	K		km/h
unit	A		Positioning system mode indication: A—autonomous mode; D—differential mode; E—estimation (dead reckoning) mode; M—manual input mode; S—simulator mode; N—Data is invalid.
checksum	*10		
<CR><LF>			End of message

8 GDP User Guidance

8.1 GDP introduction

GPD is an implementation method defined by Goke to achieve AGPS-assisted positioning. Mainly use the current navigation data Rinex file from the IGS website, and then convert it into the current ephemeris, and transmit it to the chip through the serial port, thereby realizing the accelerated positioning of the GPS chip.

8.2 How to get GPD doc.

Download the GPD file corresponding to the current time by visiting Goke's GPD server website (<http://www.goke-agps.com:7777/brdcGPD.dat>). Since the real-time ephemeris published on the IGS website is updated every 2 hours, the relative GPD file is also updated every 2 hours.

8.3 How to use GPD doc.

Upload to the chip through the serial port through the naviTrack tool provided by GOKE.

1. After the chip is powered on, click the "open" button next to the GPD icon above, and select the GPD file downloaded from the Internet. The selected file information is displayed below the tool.
2. After the file is successfully selected, click the "send" button, and the tool starts uploading.
3. After waiting for a while, the completion prompt box will appear, indicating that the upload is successful, otherwise it fails and re-upload.

8.4 How to delete GPD data in chipset

Since the GPD data is only valid for 6 hours, if the time limit is exceeded, the GPD data stored in the chip will have no effect. The user

can clear the GPD data in the chip by sending serial commands. Of course, every time new GPD data is uploaded, the original old GPD data will be cleared first.

Delete GPD data command: Enter "PGKC047" in the command input box of the naviTrack navigation tool.

8.5 The effect after using GPD

Since the ephemeris data of the currently visible satellites have been acquired, the positioning time can be effectively reduced. After using GPD, the cold start positioning time can be improved by about 10~15 seconds. Especially in the case of weak signal, it is possible to improve the positioning speed even more.

8.6 Assisted localization methods to accelerate GPD

Since pure GPD assistance also needs to rely on the GPS time information of the search sky, sometimes when the signal is poor, it still consumes too much time. Setting the current time information and rough coordinate information through the PGKC639 command can achieve faster positioning time.

Note: When setting by the 639 command, the range of latitude and longitude should be within 20km of the actual position, and the time deviation should not exceed 5 minutes.

Command: 639

Set approximate location and time information for faster positioning.

Arguments:

Arg1: Latitude, eg: 28.166450

Arg2: Longitude, for example: 120.389700

Arg3: height, eg: 0 Arg4: year

Arg5: month

Arg6: day

Arg7: Hour, time is UTC time

Arg8: points

Arg9: seconds

Example:

\$PGKC639,28.166450,120.389700,0,2017,3,15,12,0,0*33<CR><LF>

After the 639 command is successfully executed, GK9501 will return the following format:

\$PGKC001,639,3*21

8.7 GPD communication

Mainly through serial communication to transmit GPD data to the chip in blocks. The main process is as follows:

8.7.1 Switch NMEA reception to BINARY reception mode

(For the command format, please refer to GK9501 Input and Output Format.pdf)

Send: message type + toggle mode + baud rate + CheckSum

Data: \$PGKC149,1,115200*15

(Message type 149 for GPD transport)

Receive: packet header (2B) + packet length (2B) + ACK type (2B) + message type (2B) + valid flag (1B) + CheckSum (1B) + packet tail (2B)

Data: 0xaa, 0xf0, 0x0c, 0x00, 0x01, 0x00, 0x95, 0x00, 0x03, (chk), 0x0d, 0x0a

(checksum is a byte-by-byte XOR from the start of the packet length field to the field before the checksum)

8.7.2 Send GPD first data block, wait for ACK response

Send: packet header (2B) + packet length (2B) + transmission type (2B) + GPD packet number (2B) + data payload (512B) + CheckSum (1B) + packet tail (2B)

Data: 0xaa, 0xf0, 0x0b, 0x02, 0x066, 0x02, 0x00, 0x00, ..., (chk), 0x0d, 0a

Receive: packet header (2B) + packet length (2B) + ACK type (2B) + GPD packet number (2B) + valid flag (1B) + CheckSum (1B) + packet tail (2B)

Data: 0xaa, 0xf0, 0x0c, 0x00, 0x03, 0x00, 0x00, 0x00, 0x01, (chk), 0x0d, 0x0a

8.7.3 Send the remaining data blocks in sequence and wait for the ACK response

Send: packet header (2B) + packet length (2B) + transmission type (2B) + GPD packet number (2B) + data payload (512B) + CheckSum (1B) + packet tail (2B)

Data: 0xaa, 0xf0, 0x0b, 0x02, 0x066, 0x02, 0x01, 0x00,, (chk), 0x0d, 0a

(The GPD file is divided into 512-byte data blocks for transmission, and the last block less than 512 bytes is filled with 0s)

Receive: packet header (2B) + packet length (2B) + ACK type (2B) + GPD packet number (2B) + valid flag (1B) + CheckSum (1B) + packet tail (2B)

Data: 0xaa, 0xf0, 0x0c, 0x00, 0x03, 0x00, 0x01, 0x00, 0x01, (chk), 0x0d, 0x0a

8.7.4 Send GPD transfer end statement and wait for response

Send: packet header (2B) + packet length (2B) + transmission type (2B) + GPD terminator (2B) + CheckSum (1B) + packet tail (2B)

Data: 0xaa, 0xf0, 0x0b, 0x00, 0x066, 0x02, 0xff, 0xff, (chk), 0x0d, 0a

Receive: packet header (2B) + packet length (2B) + ACK type (2B) + GPD terminator (2B) + valid flag (1B) + CheckSum (1B) + packet tail (2B)

Data: 0xaa, 0xf0, 0x0c, 0x00, 0x03, 0x00, 0xff, 0xff, 0x01, (chk), 0x0d, 0x0a

8.7.5 Switch BINARY reception to NMEA reception mode

Send: Packet header (2B) + Packet length (2B) + Message type (2B) + Transmission type (1B) + Baud rate (4B) + CheckSum (1B) + Packet tail (2B)

Data: 0xaa, 0xf0, 0x0e, 0x00, 0x95, 0x00, 0x00, 0x00, 0xc2, 0x01, 0x00, (chk), 0x0d, 0x0a

Receive: packet header (2B) + packet length (2B) + ACK type (2B) + message type (2B) + valid flag (1B) + CheckSum (1B) + packet tail (2B)

Data: 0xaa, 0xf0, 0x0c, 0x00, 0x01, 0x00, 0x95, 0x00, 0x03, (chk), 0x0d, 0x0a

(Status flags: 0 for invalid, 1 for unsupported, 2 for failure, 3 for success)

9 FAQ

9.1 Communication range is too short

- The communication distance will be affected when obstacle exists.
- Data lose rate will be affected by temperature, humidity and co-channel interference.
- The ground will absorb and reflect wireless radio wave, so the performance will be poor when testing near ground.
- Sea water has great ability in absorbing wireless radio wave, so performance will be poor when testing near the sea.
- The signal will be affected when the antenna is near metal object or put in a metal case.
- Power register was set incorrectly, air data rate is set as too high (the higher the air data rate, the shorter the distance).
- The power supply low voltage under room temperature is lower than 2.5V, the lower the voltage, the lower the transmitting power.
- Due to antenna quality or poor matching between antenna and module.

9.2 Module is easy to damage

- Please check the power supply source, ensure it is in right range. Voltage higher than max value will damage the module.
- Please check the stability of power source, the voltage cannot fluctuate too much.
- Please make sure antistatic measure are taken when installing and using, high frequency devices have electrostatic susceptibility.
- Please ensure the humidity is within limited range, some parts are sensitive to humidity.
- Please avoid using modules under too high or too low temperature.

9.3 BER(Bit Error Rate) is high

- There are co-channel signal interference nearby, please be away from interference sources or modify frequency and channel to avoid interference;
- Poor power supply may cause messy code. Make sure that the power supply is reliable.
- The extension line and feeder quality are poor or too long, so the bit error rate is high;

10 Welding instruction

10.1 Reflow soldering temperature

Profile Feature	Sn-Pb Assembly	Pb-Free Assembly
Solder Paste	Sn63/Pb37	Sn96.5/Ag3/Cu0.5
Preheat Temperature min(T_{smin})	100°C	150°C
Preheat temperature max(T_{smax})	150°C	200°C
Preheat Time(T_{smin} to T_{smax})(t_s)	60-120 sec	60-120 sec
Average ramp-up rate(T_{smax} to T_p)	3°C/second max	3°C/second max
Liquidous Temperature(T_L)	183°C	217°C
Time(t_L)MaintainedAbove(T_L)	60-90 sec	30-90 sec
Peak temperature(T_p)	220-235°C	230-250°C
Average ramp-downrate(T_p to T_{smax})	6°C/second max	6°C/second max
Time 25° to peak temperature 25°C	6 minutes max	8 minutes max

10.2 Reflow soldering curve

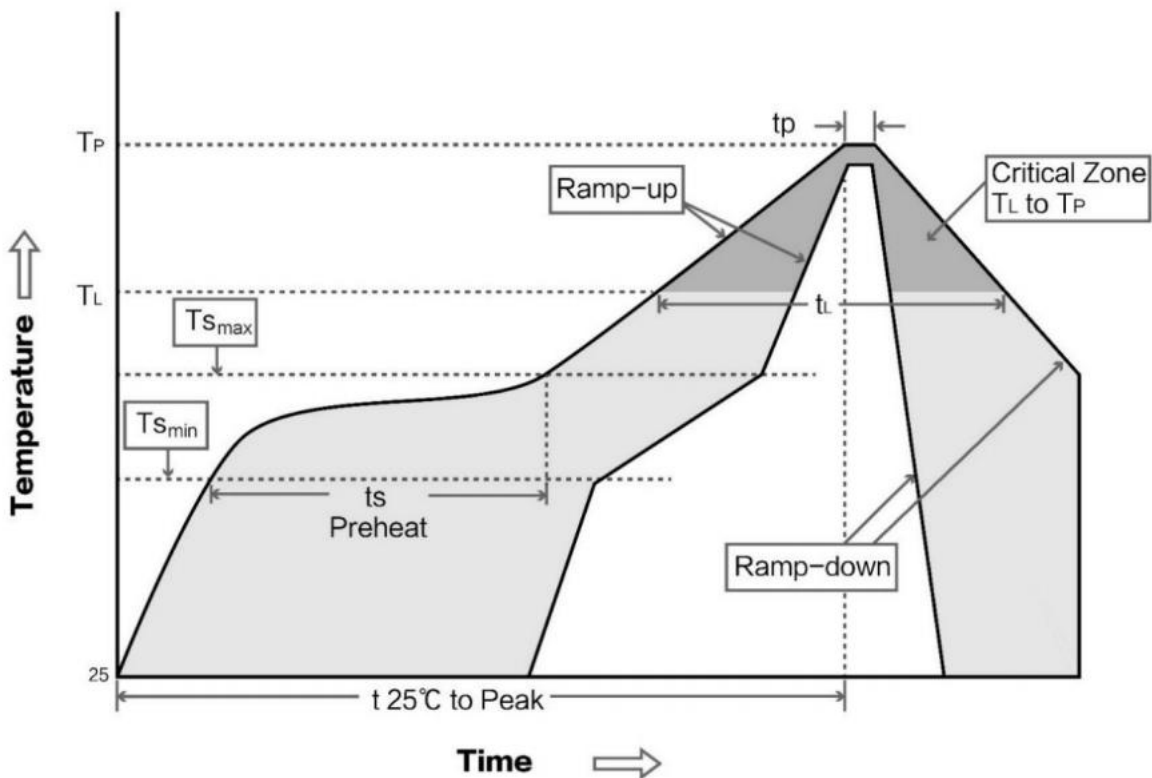

11 E108 Series

Model No.	Chipset	Satellite	Package	Size mm	Interface
<u>E108-GN02</u>	GK9501	BDS/GPS/GLONASS	SMD	16*12*2.4	UART/GPIO
<u>E108-GN02D</u>	GK9501	BDS/GPS/GLONASS	SMD	10.1*9.7*2.4	UART/GPIO
<u>E108-GN01</u>	GK9501	BDS/GPS/GLONASS	DIP	22*20*5.8	UART

12 Packing for batch order

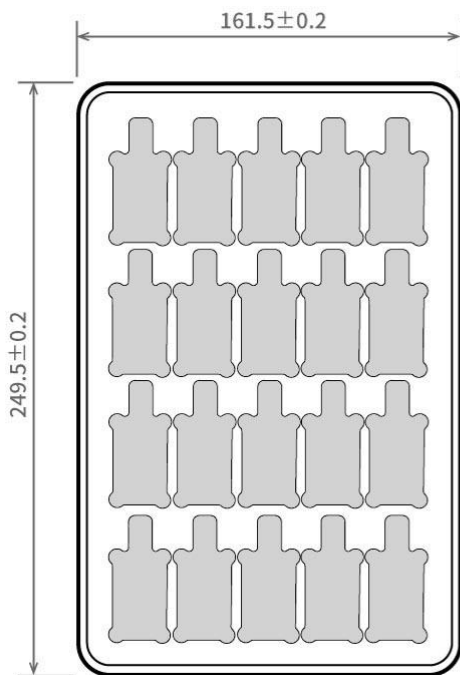

Unit: mm
 Each Layer: 20 pcs
 Each Package: 5 layers

Revision history

Version	Date	Remark	by
v1.0	2020-08-28	Original version	—
v1.1	2022-6-22	Modified version	Yan

About us

Technical support: support@cdebyte.com

Documents and RF Setting download link: www.ebyte.com

Thank you for using Ebyte products! Please contact us with any questions or suggestions: info@cdebyte.com

Phone: +86 028-61399028

Web: www.cdebyte.com

Address: B5 Mould Park, 199# Xiqu Ave, High-tech District, Sichuan, China



Chengdu Ebyte Electronic Technology Co.,Ltd.