

QRP Labs Si5351A Synthesiser Module, PCB Rev 5

The QRP Labs Si5351A-based synthesizer module can generate up to 3 different square-wave frequencies simultaneously in the range 8kHz to 160MHz with 50-ohm output impedance. It is easy to build, requiring no surface mount soldering. The Si5351A chip is truly tiny (3 x 3mm chip, 10 pins with 0.5mm spacing) but for your convenience, has been pre-soldered already to the PCB by the manufacturer! The chip is set-up using the I2C (two-wire interface) serial data protocol.

PCB Revision 4 includes pads for using a TCXO instead of the supplied 27MHz crystal. A TCXO has higher frequency stability than a crystal (less variation of frequency with temperature). The photographs in this manual are an earlier PCB revision. Please refer to the section below about using the TXCO, if you wish to use a TCXO instead of the crystal.

PCB Revision 5 is compatible with the QRP Labs 25MHz TCXO module <http://shop.qrp-labs.com/qcxptcxo> – See below section for details.

The Si5351A Synth module has a 2 x 10-pin header connector, with a footprint and pinout (see diagram, right) somewhat similar to the popular AD9850 DDS module (from eBay and elsewhere). In particular, the module is directly compatible with the Ultimate3 QRSS/WSPR kits (U3) [see Ref 1], it may be used in place of the original AD9850 DDS module, without hardware modification. Use with the U3 kit requires firmware versions v3.07 or higher, which are able to drive the I2C programmed Si5351A. Provision on the board is also made for soldering SMA sockets at the board edges for each of the three outputs, so that the module may also be used as an Si5351A “break-out” board.

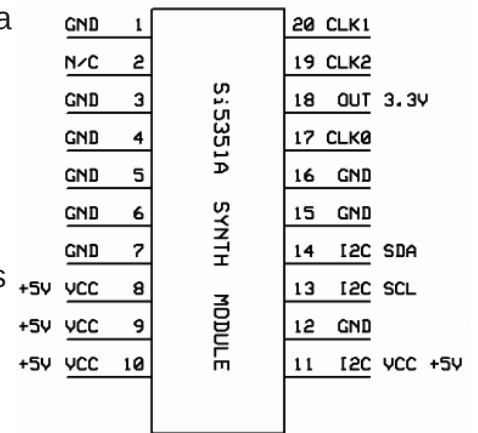

The module may be powered by 5V as it has an on-board voltage regulator to supply the Si5351A chip with 3.3V. This regulated supply voltage is also made available at pin 18. The circuit also includes level converters to interface to a 5V I2C bus. If desired, the voltage regulator and level converters can be left off the board, converting it for 3.3V operation. In this case do not fit R1, R2, R5, R6, IC2, Q1 and Q2. Fit a jumper wire across IC2 pins 2 and 3, and jumper wire between drain and source connections of the Q1 and Q2 pads.

Theory of Operation

The SiLabs Si5351A chip is a cousin of the famous and popular Si570 chip, but is much less expensive. Unlike the Si570 however, the Si5351A has no quartz crystal inside. An external reference oscillator or crystal must be provided. The reference frequency may be 25MHz or 27MHz.

In this module, a 27MHz crystal is used. This frequency is chosen because it is possible to configure the chip to produce the exact

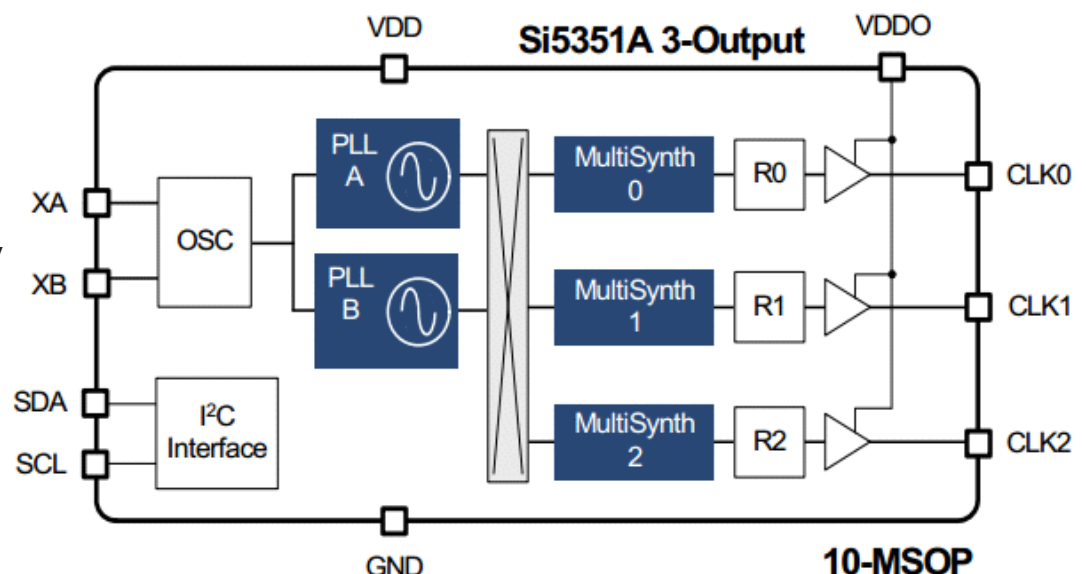

1.46Hz tone spacing for WSPR, on any amateur radio band from 2200m (136kHz) to 2m (145MHz). A 25MHz crystal cannot provide WSPR tone spacing on the 2m band.

In summary, the Si5351A chip synthesizes output frequencies in three stages. The block diagram of the chip is shown to the above (from the Si5351A datasheet).

First, a crystal reference oscillator is multiplied up to internal frequency in the range 600-900MHz. There are two PLL's in the chip, each may be selected to choose a different internal frequency. At the second stage one of the PLL frequencies is divided down to each of up to three required output frequencies. Both the upward multiplication to the internal PLL Output frequency, and the division down to the output frequency, use fractional ratios – an integer plus a fractional part consisting of 20-bit numerator and denominator. Optionally a third division stage may be configured to divide each output by a power of 2, for a maximum division ratio of 128. It is used for generating low frequency outputs between 8kHz and 500kHz.

There are a great many other facilities available in this synthesis chip. Please study the Si5351A datasheet for all the details [Ref 2].

Other than the Si5351A chip, the other components on the board are a LM317LZ variable voltage regulator configured for about 3.3V output, and a pair of bi-directional 3.3 to 5V level converters for the I2C interface. The level conversion circuit using two BS170 MOSFETs is popular and well-proven.

The circuit diagram of the Si5351A synthesizer module kit is shown below.

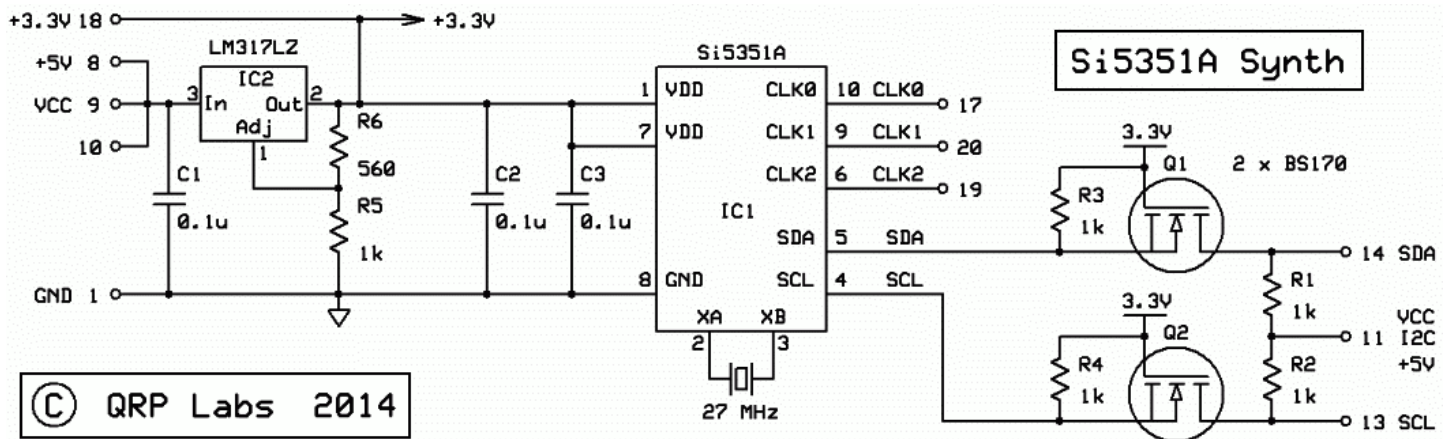

All module pins labeled “GND” are internally connected within the module. Similarly +5V pins (8, 9, 10) are also internally connected on the module PCB. Pin 11 is the pull-up resistor positive supply voltage for the level converters. For ordinary use, with a +5V I2C bus, pin 11 should be connected to +5V. The connection is provided separately (not connected to +5V internally) in case you wish to use a different I2C bus voltage.

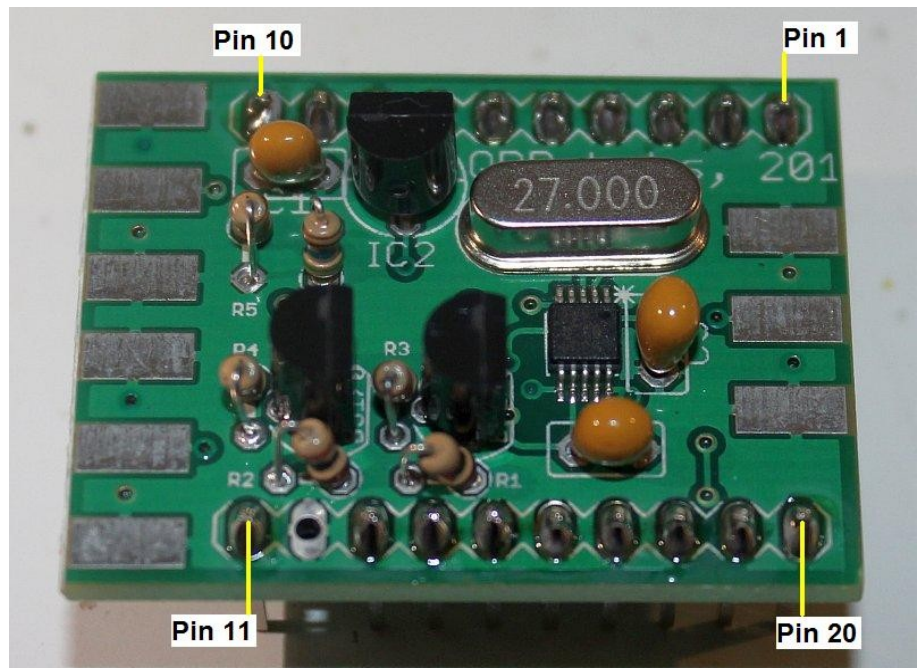

Note that in relating the pinout to the physical module, designated pin 1 is near the shorter PCB end of the module, as shown in this photograph. The photograph is an earlier PCB revision without the TXCO pad.

Construction

Assembly is very straightforward, there are very few components and the board density is not high. Please refer to the parts placement diagram below.

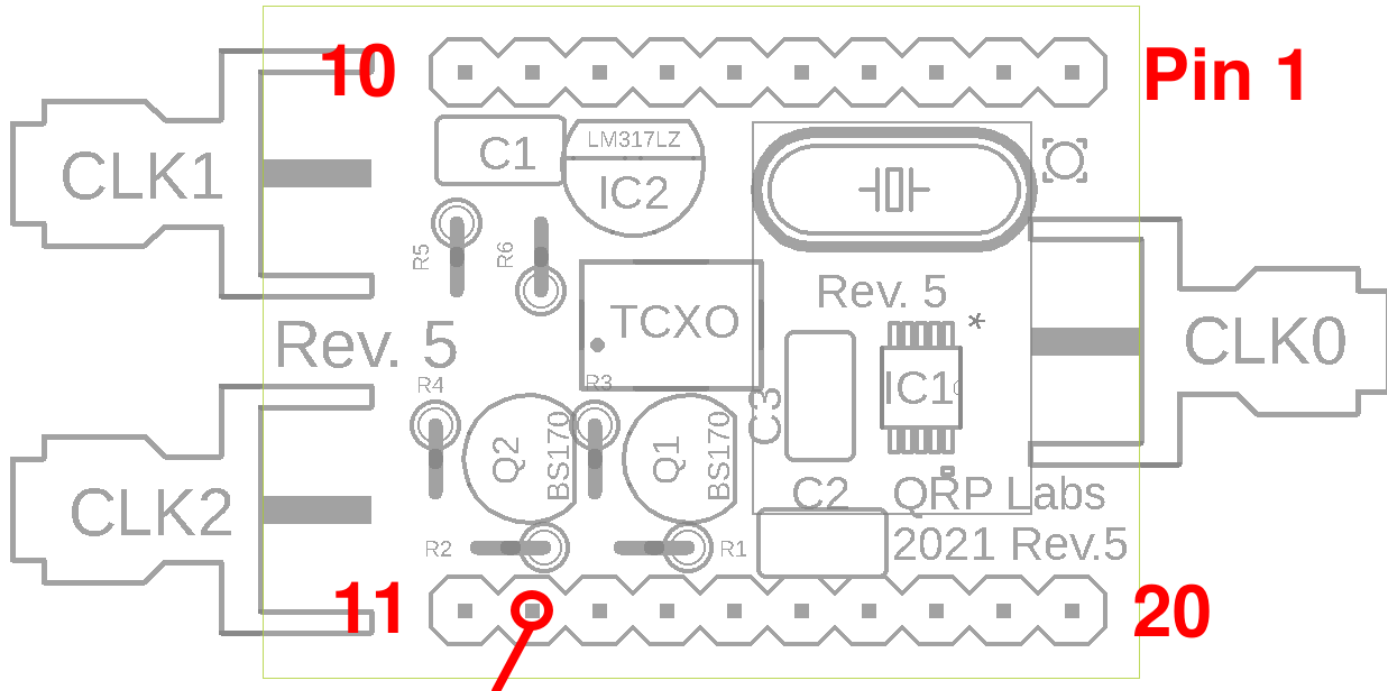

Remove pin 12 for U3 use for U3S etc., it is fine

The PCB tracks diagram (blue is bottom layer, red is top layer). The top and bottom layers are also covered by groundplanes stitched together by vias at frequent intervals, for best RF performance.

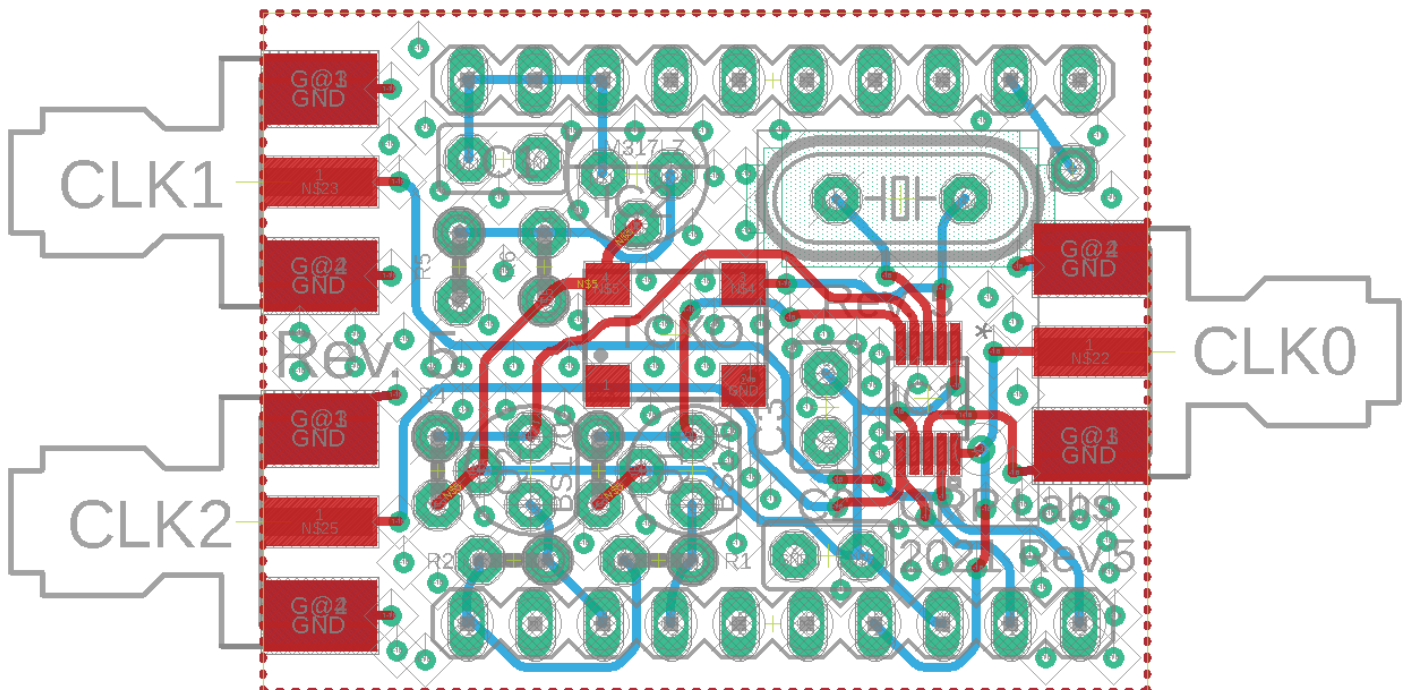

For those of you intending to use this module with an older Ultimate3 QRSS/WSPR kit [Ref 1], you must remove pin 12 from the pin header, as indicated in the diagram above, and also in the photograph on the previous page. This is because this pin is grounded on the module, but on the U3 the connection was used for one of the data control signals to the AD9850 DDS module, and is also shared with an LCD data pin. Grounding this connection would prevent anything being displayed on the U3 LCD, so the pin must be removed from the pin header, before installation. The pin is easy to pull out with pliers or a wire-cutter (see photograph, right). **The pin does not need to be removed for use in the U3S kit.**

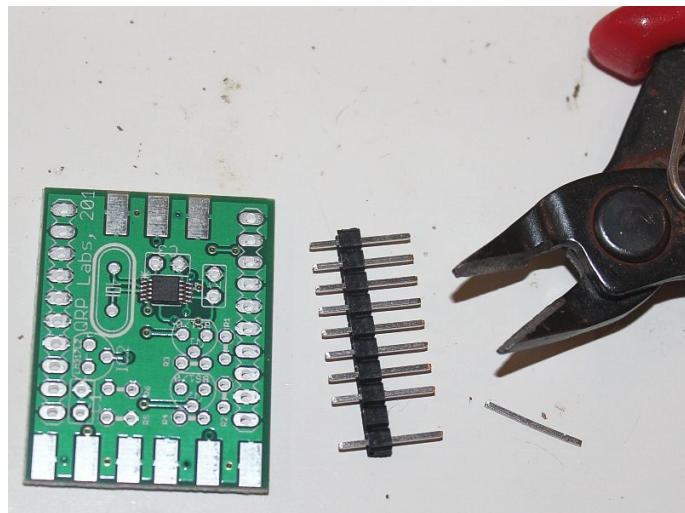

Take care to follow the silkscreen printing on the PCB for the correct position and orientation of IC2 (the LM317LZ) and transistors Q1/Q2. Capacitors C1, C2 and C3 are identical (0.1uF). Be careful to check the resistors carefully before installation:

R1-5: 1K-ohm (colour code: brown-black-red)
R6: 560 ohms (colour code: green-blue-brown)

I recommend installation in this order: resistors, capacitors, crystal, then transistors/voltage regulator, and finally the two 10-pin headers. It will be easier to solder the components BEFORE installation of the pin headers. But really, construction order is not critical at all.

NOTE: commonly the PCBs are supplied with an extra strip of PCB material down one edge, this is just part of the manufacturing process and should be snapped off.

Do not install the crystal and C3 if you intend to use a TCXO instead (see below).

If you are using this Si5351A Synthesizer module for your own projects (not in the Ultimate3 kit), you may wish to solder on SMA socket connectors to positions CLK0, CLK1 and CLK2 as indicated in the parts placement diagram above.

After completing the soldering, it is always a good idea to admire (and check!) your work using a magnifying glass or jewelers loupe such as the one pictured here.

Check the resistors are installed in the right place (remember R6 is 560 ohms) and the voltage regulator is IC2 (don't mix LM317LZ and BS170!). Check the Si5351A chip is nicely soldered too: even factory SMD robots might make mistakes sometimes!

For those using the module in the Ultimate3 kit, make sure there is

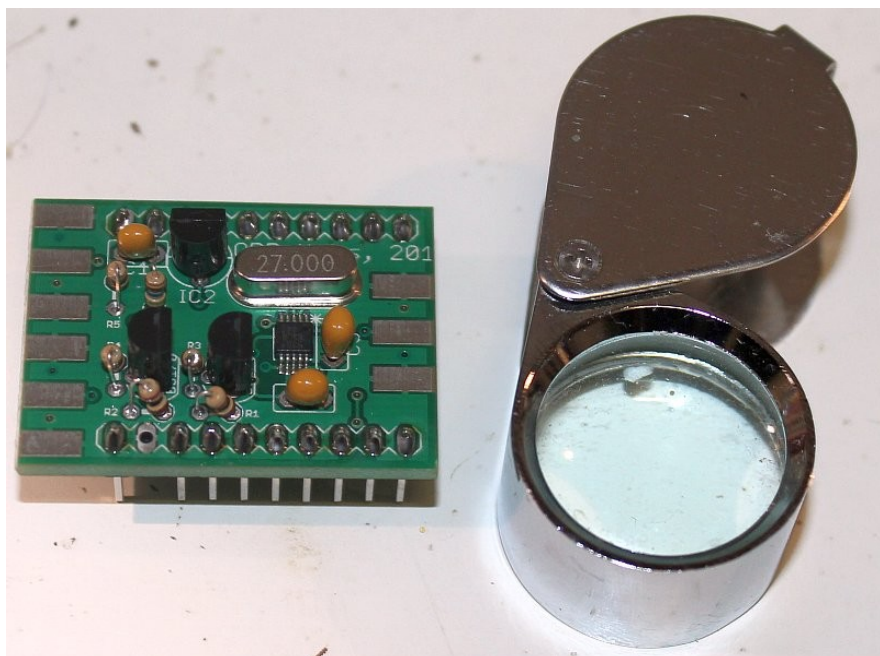

no pin soldered at pin 12. When using the module in the Ultimate3S kit, you can keep pin 12.

On applying power to the board, you should find a voltage of approximately 3.3V (up to 3.5V) at pin 18 of the module. No output frequencies are generated until you have programmed the Si5351A configuration registers via the I2C interface.

TCXO option:

PCB revision 4 (and above) include component pads for a 5 x 7mm Temperature Controlled Crystal Oscillator. This has higher frequency stability than a crystal. Make sure that your TCXO matches the pinout, see this diagram. Simply solder the SMD TCXO in the position labelled "TCXO" on the PCB silkscreen, and do not install the 27MHz crystal.

5 x 3.2mm sized TCXOs can also be soldered to these pads. A possible part is FOX924B-27.000 see <http://www.foxonline.com/pdfs/fox924.pdf> which is inexpensive at Digi-key, part number 631-1075-1-ND.

Note that many TCXO's have discrete frequency jumps which can cause problems with narrow-band modes such as WSPR. **The above-mentioned FOX924B component has this frequency stepping problem.**

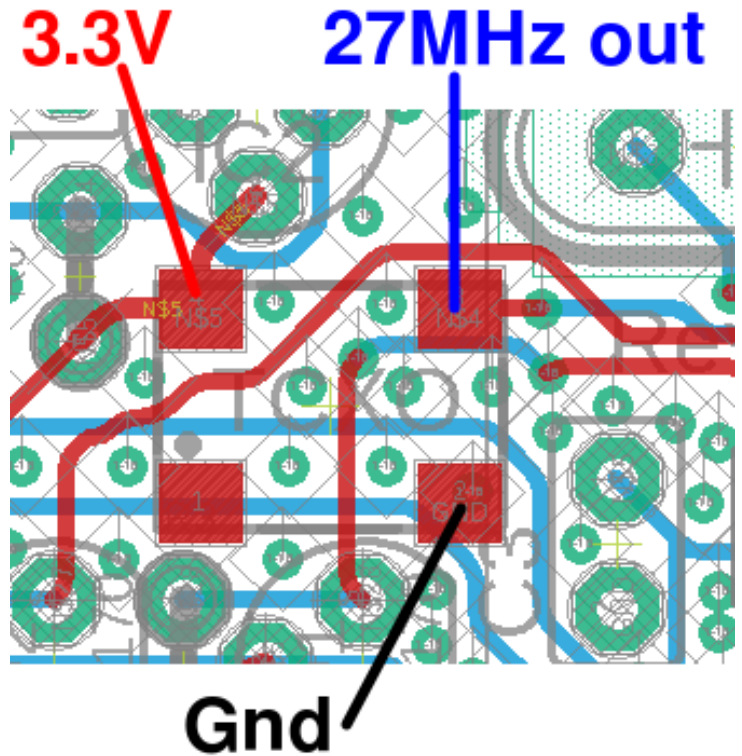

QRP Labs TCXO option:

PCB revision 5 (and above) is compatible with the QRP Labs TCXO module <http://shop.qrp-labs.com/qcxptcxo>. This is a 25MHz TCXO that has excellent performance yet low cost, and it has an analog correction circuit, suitable for WSPR and other narrow-band modes (it has NO frequency stepping problem mentioned above in relation to the FOX924 and others).

To install the 25MHz TCXO module, simply do not install the 27MHz crystal supplied, and do not install C3. Place the TCXO module on the board as shown in the following photographs. There are three connections between the TCXO module and the main board:

- GND (Ground, 0V)
- VDD (3.3V supply)
- 25Mhz Output

When the TCXO module is placed on the board with its "window" over the Si5351A, the three connection pads line up perfectly with the holes on the main PCB. You can make the connections with component off-cut wires. For Gnd and VDD you can use the 0.1uF ("104") C3 capacitor as shown, passed through the holes of both the main board and the TCXO module board. **In that case, remember to solder the C3 wires both on the underside of the main board, and on the top side of the 25MHz TCXO board.**

Remember that for most QRP Labs kits, you will need to manually adjust the reference frequency configuration from the default 27MHz to 25MHz for the TCXO; even if you are using GPS frequency discipline, this is still the case: it must be set manually to 25MHz first.

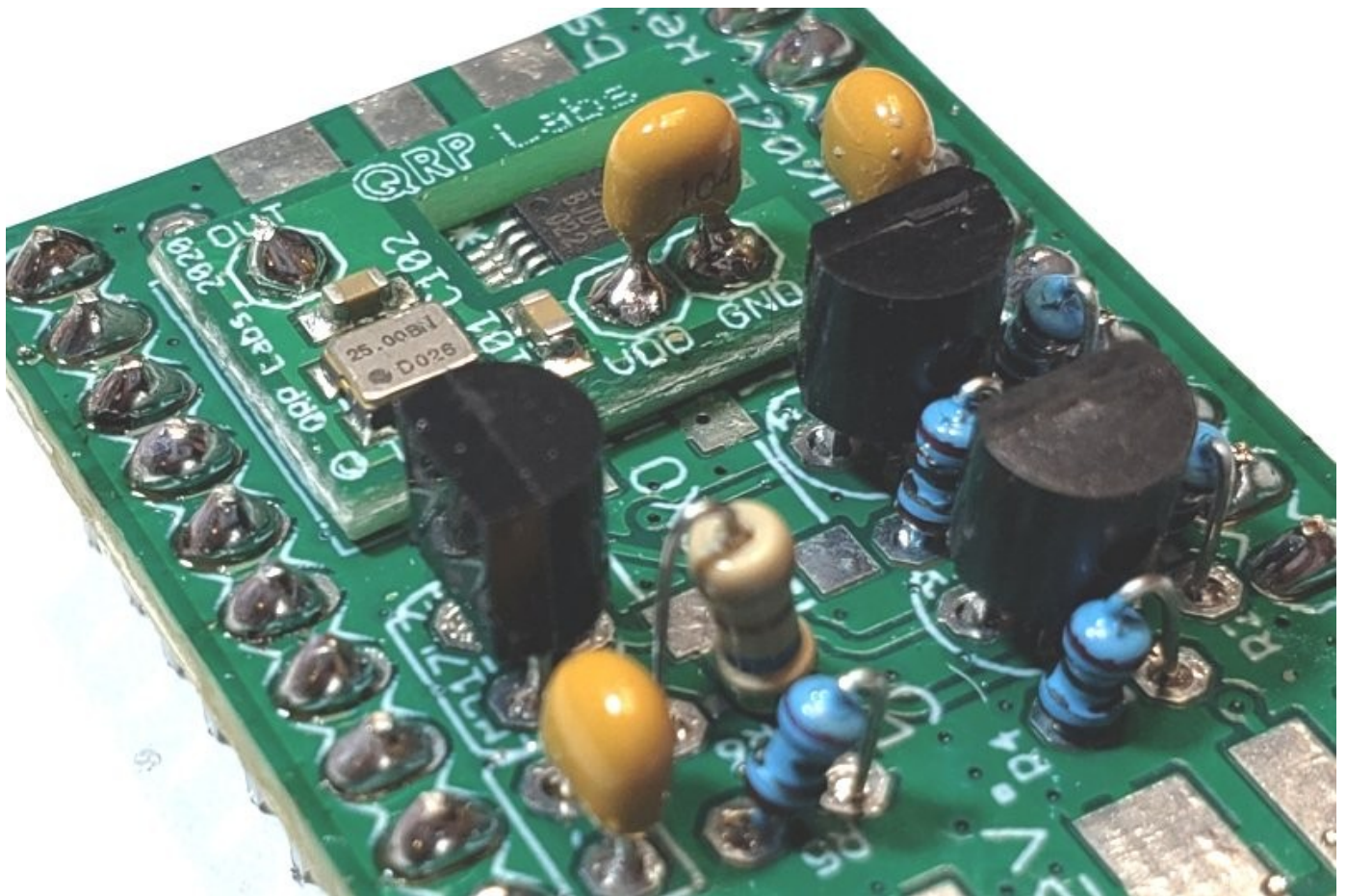
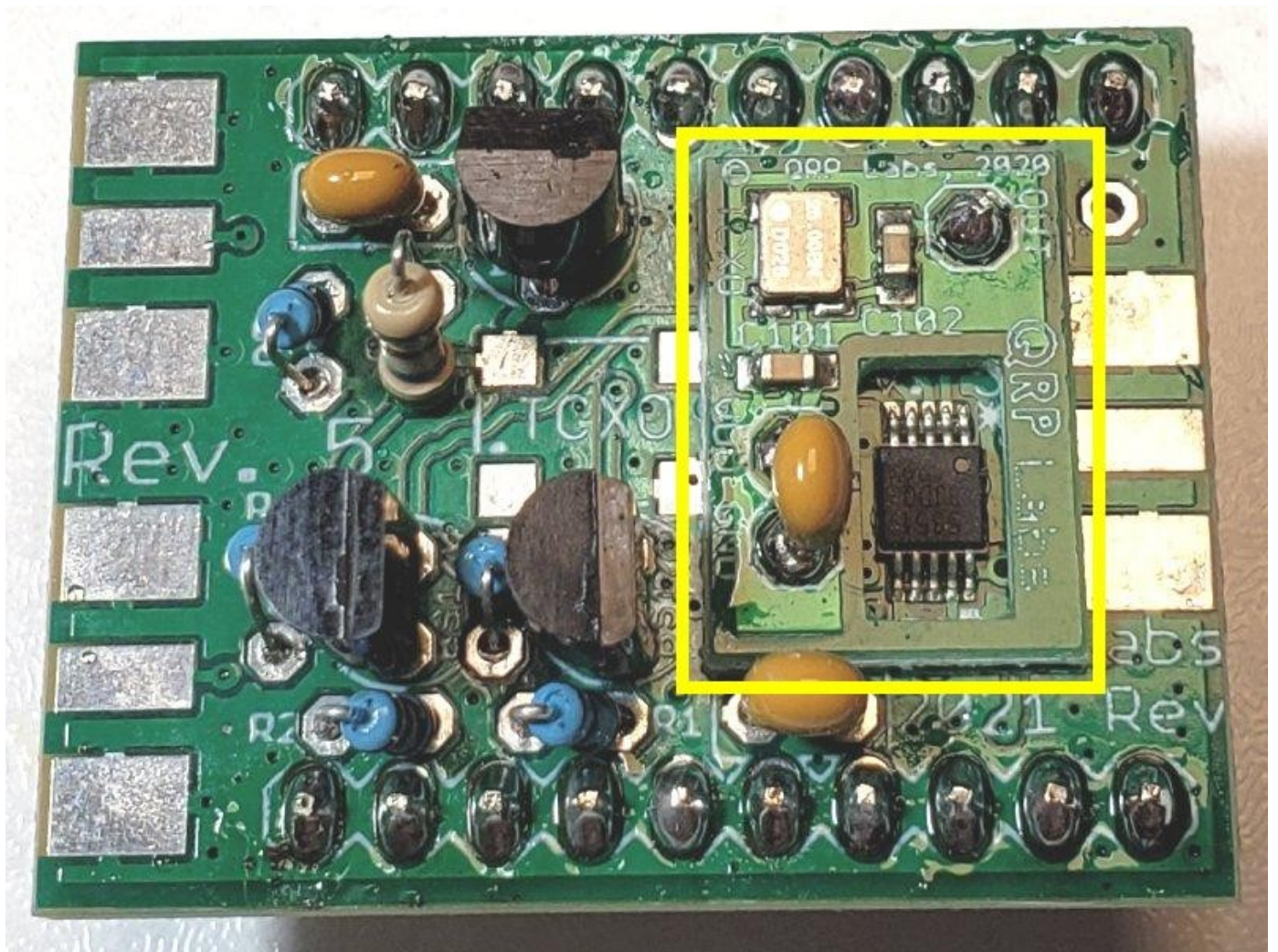

References:

- 1) Ultimate3 QRSS/WSPR kit: <http://www.qrp-labs.com/ultimate3>
- 2) SiLabs Si5351A page (including datasheet):
<http://www.silabs.com/products/clocksoscillators/clock-generator/Pages/clock-vcxo.aspx>
- 3) QRP Labs web site kit page: <http://www.qrp-labs.com/synth>
- 4) QRP Labs discussion group <https://groups.io/g/qrplabs>
- 5) Follow QRP Labs on Twitter @qrplabs and Facebook <http://www.facebook.com/QRPlabs>

Document updates:

- 1) 05-Jan-2016: clarification of what components to omit and jumpers to fit, for 3.3V supply operation. References updated to <http://www.qrp-labs.com> and kit web page
- 2) 26-Sep-2016: For PCB revision 4; added pads for TCXO
- 3) 29-Oct-2020: Correct URL for discussion group, now at groups.io
- 4) 10-Nov-2020: Add PCB track diagram
- 5) 30-Jul-2021: For PCB revision 5, added details of how to install the QRP Labs 25MHz TCXO module.