

Controlling additional relays using the Ultimate3S “Aux”

1. Introduction

The Ultimate3S kit is built around the inexpensive 28-pin ATmega328 processor. This processor has limited Input/Output (I/O) pins yet is able to control the LCD, buttons, 6 relays, and Si5351A synthesiser. This is accomplished by sharing I/O pins in some cases so that they are used by more than one peripheral.

A firmware feature exists which allows control of up to 4 external relays (or other digital I/O), in addition to everything the processor is already doing. These additional outputs might be used to control relays to switch between different antennas (for realtime comparative antenna testing), or for switching attenuators to achieve different power level transmissions, or for many other purposes!

This document explains how to use this feature.

2. The Aux configuration parameter in the Ultimate3S menu

Each of the Ultimate3S mode transmission screens contains a parameter at the bottom right of the screen, shown here circled in red:



This parameter (3 in this example) is the “Aux” output setting for this transmission screen. It may have the values 0..F. In binary this corresponds to 0000..1111. The value configured here appears on the 4-bit LCD data bus, signals labelled D4..D7 at the edge of the Ultimate3S PCB:

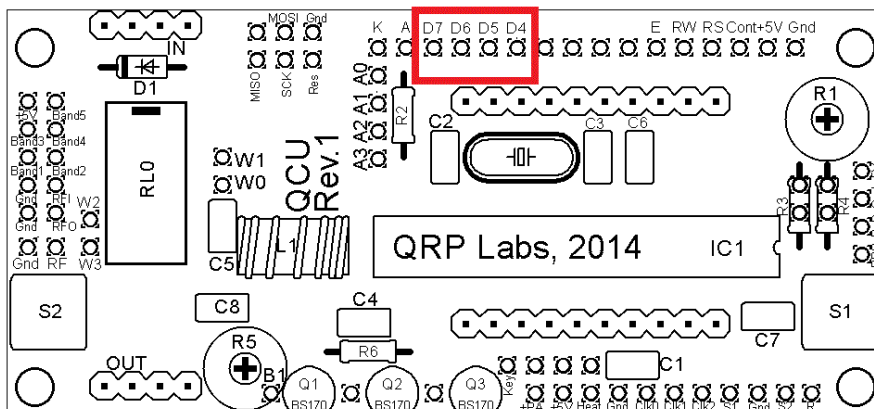

This configuration allows a different value for each of the transmission screens. These four output signals can be used to control external relays, for example.

The mapping of “Aux” parameter to the output voltages at the LCD pins D4..D7 is as follows:

Aux setting	D4	D5	D6	D7
0	Low	Low	Low	Low
1	Low	Low	Low	High
2	Low	Low	High	Low
3	Low	Low	High	High
4	Low	High	Low	Low
5	Low	High	Low	High
6	Low	High	High	Low
7	Low	High	High	High
8	High	Low	Low	Low
9	High	Low	Low	High
A	High	Low	High	Low
B	High	Low	High	High
C	High	High	Low	Low
D	High	High	Low	High
E	High	High	High	Low
F	High	High	High	High

In this table “Low” means a binary 0, a voltage of approximately 0V. “High” means a binary 1, a voltage of approximately 5V. The state of these four outputs can therefore be individually controlled, with a different setting for each transmission configuration of the Ultimate3S.

Readers familiar with binary to hexadecimal conversion will easily recognise the pattern of this table. But note that “D4” is the most significant bit, and “D7” is the least significant bit, which is the opposite “significance” to the LCD module connection.

3. “Noise” on the 4 output control signals

The four outputs controlled by the “Aux” parameter are shared with the LCD. This means that when the microcontroller updates the text on the LCD, it sends 1’s and 0’s to this 4-bit LCD data bus. When the display write is finished, the state of the 4 signals is returned to the value controlled by the “Aux” parameter. The pulse width and the number of pulses depends on what is being written to the screen. This pulsing of the four control signals may need to be considered, depending on the application.

The typical pulse width is less than 2us, as shown in this oscilloscope trace of the LCD’s D7 output where the horizontal timebase is 500ns/division. In this case the “Aux” setting was for the D7 output to be zero (low).

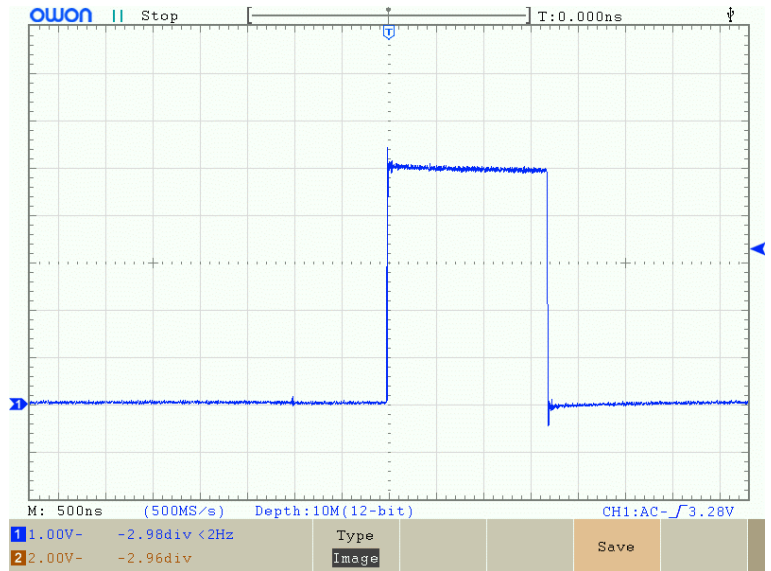

The following oscilloscope trace has a horizontal timebase of 200ms/division and was taken during a WSPR transmission. During a WSPR transmission the Ultimate3S kit writes the current symbol transmitted to the display on the bottom row. Again the trace shows the D7 output and D7 is configured to be zero (low). Note the short burst of activity on the D7 signal, which occurs once per WSPR symbol (every 0.68 seconds).

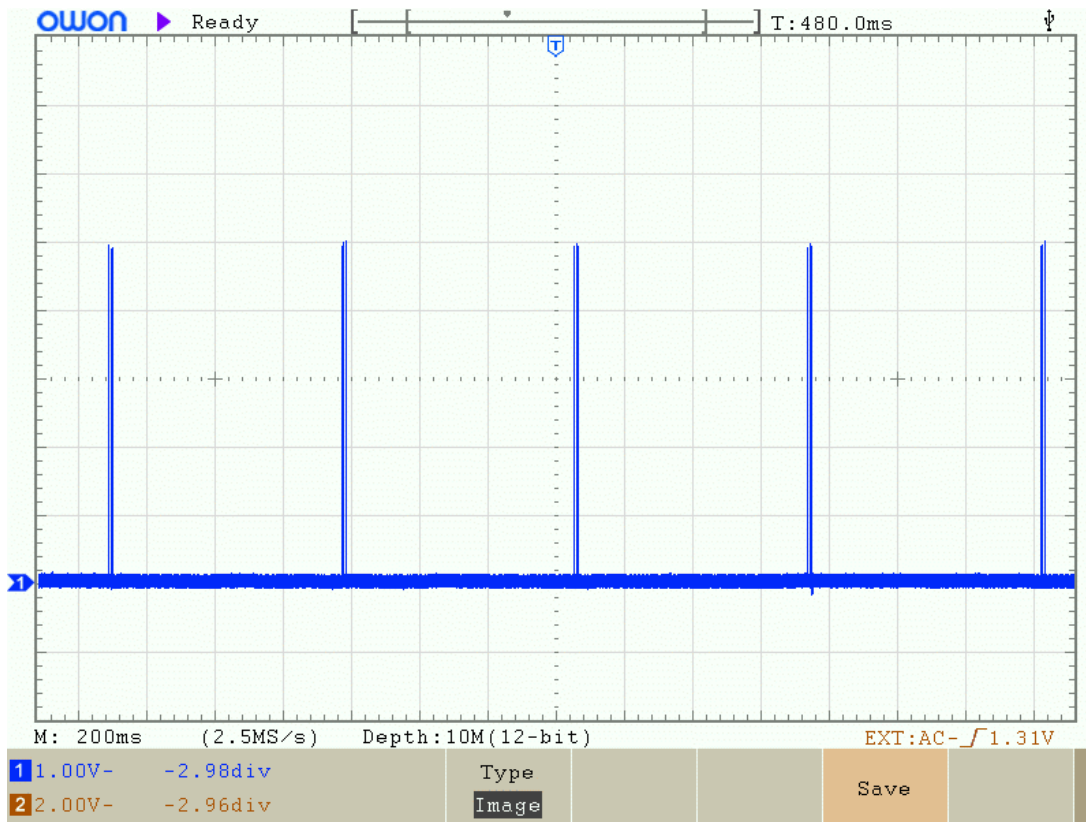

A relay controlled by these outputs will not actually change state due to these short bursts of data. The relay coil simply is slower to react than the duration of the short burst of data. The relay coil cannot de-energise enough for the contact to switch. So the short data bursts are just ignored, as far as the relay is concerned, in this typical use case.

However, when the Ultimate3S kit is powered up, a short “Buzz” of relay chatter can be heard, since there are many display writes when the kit is initialising. Again when the menu system is exited and the system prepares to start transmissions, there is a similar short relay chatter. There may be other conditions when a lot of display write occurs, where the amount of data transfer to the LCD is sufficient to cause the relay to activate/de-activate.

For this reason it is probably best practice to take simple precautions to filter out the short pulses during LCD write, to avoid causing false activation/de-activation of relays (or other circuits) connected to these outputs. Fortunately this circuit contains few parts and is simple to construct.

4. A simple circuit to filter LCD write pulses

Filtering out these pulses during LCD writes is a simple Low Pass Filter or “integrator”, something to slow down the reaction to pulses enough that short pulses are ignored. This “integrator” may be easily included in the usual transistor driver circuit that controls a relay coil.

An example circuit is shown below (left). It was constructed on a small piece of perforated matrix board. The relay used here is a TX2-5V, the same type as used in the QRP Labs relay-switched filter kit, which is also available for sale in the spare parts category of the QRP Labs shop. Other relays could also be used, and the supply voltage shown for this circuit can be changed to 12V to suit 12V relays.

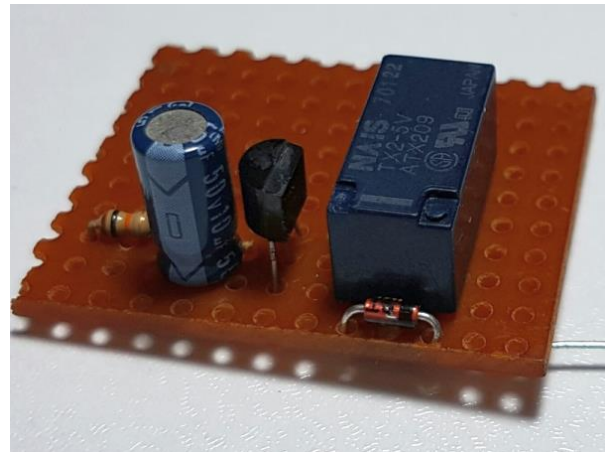
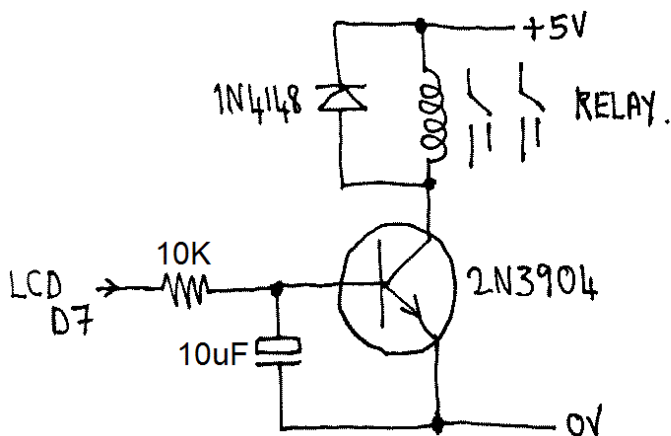

The resistor and capacitor in the base circuit of the transistor form an integrator which ignores the rapid pulses of the LCD write. It also delays the activation of the relay activation/de-activation. But this will usually not be critical. The “Aux” parameter is effected on the LCD signals D4-D7 at the end of the prior transmission. So in the case of a sequence of WSPR transmissions for example, the next Aux



setting is applied 8 seconds at the end of the previous transmission, and there is an 8 second gap before the start of the next.

None of the component values are critical. Any small-signal NPN transistor will suffice, and similarly any small diode across the relay coil (to protect the transistor. The resistor should be kept higher than 1K to protect the base-emitter junction of the transistor. The time-constant of the resistor-capacitor combination shown is $10,000 \times 0.00001 = 0.1$ seconds. This is not the same as the delay time since the transistor will “switch” at approximately 0.7V but it will give some rough idea of the time delay involved.

5. Conclusion

This simple circuit can be used to interface these four auxiliary output control signals to relays to control external equipment such as relay switching between antennas for comparison purposes, or switched attenuators, or many other possible uses.

Antonio EA1CDV presents a method for real-time antenna comparisons here <http://qrp-labs.com/ultimate3/u3info/antcomp.html> that is an excellent discussion of using the “Aux” outputs for a practical purpose.

6. Document history

1.1 07-Dec-2016 Just a minor typo correction in section 2