

QRP Labs QCX+ CW Transceiver

QCX+ 5W CW Transceiver kit assembly instructions

PCB Rev 4

The “QCX+”: a single band, high performance 5W CW Transceiver with built-in alignment and test equipment, iambic keyer, WSPR beacon mode, and more...

Designed and produced by QRP Labs, 2017-2025



pictured with:

Heil Sound Pro Set 3 headphones <https://heilsound.com/products/pro-set-3/>

and

Palm Radio pico paddle <http://palm-radio.de>

Contents

1. Introduction.....	5
2. Parts list.....	6
3. Assembly – general guidelines.....	11
3.1 Inventory parts.....	17
3.2 Wind and install transformer T1.....	18
3.3 Install IC2 socket.....	24
3.4 Install DIP integrated circuits IC3, IC5-10.....	25
3.5 Install all 100nF (0.1uF, “104”) capacitors.....	26
3.6 Install all 470nF, “474” capacitors.....	27
3.7 Install all 1nF, “102” capacitors.....	28
3.8 Install all 10nF, “103” capacitors.....	29
3.9 Install 47nF, “473” capacitors.....	30
3.10 Install 39nF, “393” capacitor.....	31
3.11 Install 2.2nF, “222” capacitors.....	32
3.12 Install 33nF, “333” and 3.3nF, “332” capacitors.....	33
3.13 Install capacitors C25 and C26 from the Low Pass Filter kit.....	34
3.14 Install capacitors C27 and C28 from the Low Pass Filter kit.....	35
3.15 Install capacitor C30.....	36
3.16 Install capacitors C5 and C8.....	37
3.17 Install 1uF, “105” capacitors C21, and C22.....	38
3.18 Install 2.2uF, “225” capacitor C31.....	39
3.19 Install 1N4148 diodes.....	40
3.20 Install 1N5819 diode.....	41
3.21 Install 20MHz crystal XTAL1.....	42
3.22 Install 27MHz crystal XTAL2.....	43
3.23 Install all main PCB 10K resistors.....	44
3.24 Install all main PCB 1K resistors.....	45
3.25 Install all main PCB 3.3K resistors.....	46
3.26 Install all 100-ohm resistors.....	47
3.27 Install 120K resistors.....	48
3.28 Install 33K resistors.....	49
3.29 Install 47K resistors.....	50
3.30 Install 36K resistors.....	51
3.31 Install the main PCB 270-ohm resistor.....	52
3.32 Install 1.2K or 820-ohm resistor R42.....	53
3.33 Install 150-ohm resistor R41.....	54
3.34 Install 3.9K resistor R61.....	55
3.35 Install 4.3K resistor R18.....	56
3.36 Install 5.1K resistor R11.....	57
3.37 Install 750K resistor R35.....	58
3.38 Install 500-ohm multi-turn trimmer potentiometer.....	59
3.39 Install 50K multi-turn trimmer potentiometers.....	60
3.40 Install two 47uH inductors.....	61
3.41 Install 10uF capacitors.....	62
3.42 Install 470uF capacitors.....	63
3.43 Install 30pF trimmer capacitor C1.....	64
3.44 Install MPS751 transistor Q6.....	65
3.45 Install all BS170 transistors.....	66
3.46 Install 2x3-pin in-circuit programming header.....	67

3.47	Install power connector.....	68
3.48	Install 7805 voltage regulator IC11.....	69
3.49	Wind and install toroid L4.....	70
3.50	Wind and install toroid L2.....	72
3.51	Wind and install toroids L1 and L3.....	73
3.52	Install RF output BNC connector.....	74
3.53	Install 3.5mm stereo jack connectors.....	75
3.54	Install header pin connectors JP3, JP4 and JP5.....	76
3.55	Install Front panel PCB resistors R44 and R65.....	78
3.56	Install 270-ohm resistor R48.....	78
3.57	Install 1K resistor R45.....	79
3.58	Install 10K resistor R46.....	79
3.59	Install 2x5-pin header connector socket JP1.....	80
3.60	Install two 2x3-pin header connector socket JP2 and JP3.....	80
3.61	Install 22K trimmer potentiometer R47.....	81
3.62	Install button switches S2 and S3.....	81
3.63	Install On/Off switch S1.....	82
3.64	Install rotary encoder.....	82
3.65	Install gain control potentiometer.....	83
3.66	Install LCD module.....	84
3.67	Install knobs.....	85
3.68	Install optional AGC module.....	85
3.69	Install optional TCXO module.....	85
3.70	Install microcontroller.....	87
3.71	Plug together the two boards.....	87
3.72	Installation in optional Enclosure.....	87
3.73	Connections for basic operation.....	88
3.74	Adjustment and alignment.....	89
3.75	Experiments, modifications and the QCX+ Dev kit.....	94
3.76	QCX+ GPS interface and PTT output.....	97
3.77	QCX+ CAT port.....	100
4.	Operating instructions.....	100
5.	Circuit design of the QCX+.....	101
5.1	Block diagram and summary.....	101
5.2	Circuit diagram.....	101
5.3	Synthesised oscillator.....	103
5.4	Transmit/Receive switch.....	105
5.5	Band Pass, Phase Splitter, QSD and pre-amps.....	105
5.6	90-degree audio phase shift.....	106
5.7	CW filter.....	107
5.8	Audio amplifier.....	108
5.9	Transmit signal routing and PA driver.....	109
5.10	Class-E Power Amplifier.....	110
5.11	Low Pass Filter.....	112
5.12	Key-shaping circuit.....	112
5.13	Microcontroller.....	113
5.14	Optional GPS interface.....	118
5.15	In Circuit Programming (ISP) interface.....	119
5.16	Test Equipment.....	119
5.17	5V voltage regulator.....	121
6.	Fault-finding.....	122

6.1 Blank LCD or blocked LCD.....	122
6.2 No backlight at all.....	122
6.3 A row of blocks appears on the top row.....	122
6.4 DC voltage readings.....	123
6.5 RF Power output check.....	125
7. Measurements.....	127
7.1 Equipment.....	127
7.2 Transceiver current consumption.....	127
7.3 Transmitter power output.....	128
7.4 Class-E Power Amplifier drain waveform.....	129
7.5 RF envelope key-shaping.....	129
7.6 Low Pass transmitter harmonic output filter characteristics.....	130
7.7 Band Pass receiver input filter characteristics.....	130
7.8 Quadrature Sampling Detector bandwidth.....	133
7.9 CW Filter response.....	134
7.10 Unwanted sideband rejection.....	135
8. Resources.....	136
9. Document Revision History.....	136

1. Introduction

Thank you for purchasing this high performance single-band 5W CW transceiver kit, the QCX+ (for QRP Labs CW Xcvr +). This kit has a long list of features!

- Easy to build, two-board design, spacious 10 x 13cm main board with main circuit and connectors; vertical front panel board with LCD and all controls board-mounted
- Professional quality double-sided, through-hole plated, silk-screen printed PCBs
- Choice of single band, 160, 80, 60, 40, 30, 20 or 17m
- Approximately 3-5W CW output (depending on supply voltage)
- 7-16V recommended supply voltage
- Class E power amplifier, transistors run cool... even with no heatsinks
- 7-element Low Pass Filter ensures regulatory compliance
- CW envelope shaping removes key clicks
- High performance receiver with at least 50dB of unwanted sideband cancellation
- 200Hz CW filter with no ringing
- Si5351A Synthesized VFO with rotary encoder tuning
- 16 x 2 blue backlight LCD screen
- Iambic keyer or straight key option included in the firmware
- Simple Digital Signal Processing assisted CW decoder, displayed real-time on-screen
- On-screen S-meter
- On-screen real time clock
- Full or semi QSK operation using fast solid-state transmit/receive switching
- Frequency presets, VFO A/B Split operation, RIT, configurable CW Offset
- Configurable sidetone frequency and volume
- Connectors: Power, 3.5mm keyer jack, 3.5mm stereo earphone jack, BNC RF output
- Built-in test signal generator and alignment tools to complete simple set-up adjustments
- Built-in test equipment: voltmeter, RF power meter, frequency counter, signal generator
- Beacon mode, supporting automatic CW or WSPR operation
- GPS interface for reference frequency calibration and time-keeping (for WSPR beacon)
- CAT control interface
- Optional 50W PA kit
- Optional Dev board kit
- Optional TCXO module
- Optional aluminium extruded cut/drilled/laser-etched black anodized enclosure

No test equipment is required to build, align and operate this CW transceiver. Its innovative self-alignment and self-test features will help and guide you in setting up the transceiver in a few easy steps. The kit also includes a voltmeter, RF power meter, frequency counter and signal generator which can aid in debugging and fault-finding.

We hope you enjoy building and operating this kit! Please read this assembly manual carefully, and follow the instructions step by step in the recommended order. Later in the manual the circuit design is described in detail and we recommend reading and understanding this section too, to get the maximum enjoyment and education from your new radio.

Typical performance measurements are shown in the measurements section. The operation section of the manual describes transceiver, alignment and test equipment operation in detail.

There is a single page reference “cheat sheet” in the (separate) operating manual

Please check the QCX+ web page <http://qrp-labs.com/qcxp> for any updates tips, etc., before starting the assembly.

Please make use of troubleshooting resources at <http://grp-labs.com/qcxp> if you have any problems. If you need further help, join the QRP Labs discussion forum on groups.io and post a message about your problem.

2. Parts list

Resistors (all fixed resistors are ¼-Watt, 1% tolerance)

Qty	Value	Description	Component numbers
4	100-ohms	Brown-black-black-black-brown	R5, 6, 8, 9
1	150-ohms	Brown-green-black-black-brown	R41
2	270-ohms	Red-purple-black-black-brown	R48, 50
11	1K	Brown-black-black-brown-brown	R3, 4, 19, 26, 37, 45, 49, 54, 55, 62, 63
1	1.2K or 820-ohms	Brown-red-black-brown-brown or Grey-red-black-black-brown	R42 (supplied as 820-ohms from July 2022)
13	3.3K	Orange-orange-black-brown-brown	R12, 13, 15, 16, 20, 22, 23, 25, 44, 53, 56, 59, 65
1	3.9K	Orange-white-black-brown-brown	R61
1	4.3K	Yellow-orange-black-brown-brown	R18
1	5.1K	Green-brown-black-brown-brown	R11
16	10K	Brown-black-black-red-brown	R1,2,7,10,14,21,34,36,39,40,46,51,52,57,58, 64
2	33K	Orange-orange-black-red-brown	R28, 29
2	36K	Orange-blue-black-red-brown	R32, 33
2	47K	Yellow-purple-black-red-brown	R30, 31
3	120K	Brown-red-black-orange-brown	R38, 43, 60
1	750K	Purple-green-black-orange-brown	R35
1	500-ohm	Multi-turn trimmer potentiometer	R27
2	50K	Multi-turn trimmer potentiometer	R17, 24
1	5K	Linear potentiometer	R1 (Front panel)
1	22K	Trimmer potentiometer	R47

Capacitors (50V, Multi-layer Ceramic capacitors)

Qty	Value	Description	Component numbers
5	1nF	Label "102"	C14, 16, 18, 23, 33
2	2.2nF	Label "222"	C19, 20
1	3.3nF	Label "332"	C53
4	10nF	Label "103"	C4, 7, 10, 42
1	33nF	Label "333"	C15
1	39nF	Label "393"	C17
2	47nF	Label "473"	C9, 13
16	0.1uF	Label "104"	C2, 3, 6, 12, 29, 32, 34-36, 39-41, 48-50, 52
5	0.47uF	Label "474"	C11, 43-46
2	1uF	Label "105"	C21, 22

Qty	Value	Description	Component numbers
1	2.2uF	Label "225"	C31
3	10uF	Electrolytic	C37, 38, 51
2	470uF	Electrolytic	C24, 47
1	30pF	Ceramic trimmer capacitor	C1

Band-specific capacitors (50V, 5% capacitors which must be C0G/NP0 type)

Note: depending on band, some capacitors may be left over at the end. This is normal!

160m

Qty	Value	Description	Component numbers
1	22pF	Label "220"	C5
1	100pF	Label "101"	C8
1	820pF	Label "821"	C30
2	820pF	Label "821"	C27, 28
2	2200pF	Label "222"	C25, 26

80m

Qty	Value	Description	Component numbers
1	39pF	Label "390"	C5
1	22pF	Label "220"	C8
1	180pF	Label "181"	C30
2	470pF	Label "471"	C27, 28
2	1200pF	Label "122"	C25, 26

60m (C30 is two capacitors in parallel)

Qty	Value	Description	Component numbers
1	39pF	Label "390"	C5
1	22pF	Label "220"	C8
1	30pF	Label "300"	C30 (C30 is two capacitors in parallel)
1	56pF	Label "560"	C30 (C30 is two capacitors in parallel)
2	680pF	Label "681"	C27, 28
2	1200pF	Label "122"	C25, 26

40m (no C8 capacitor)

Qty	Value	Description	Component numbers
1	39pF	Label "390"	C5
1	56pF	Label "560"	C30
2	270pF	Label "271"	C27, 28
2	680pF	Label "681"	C25, 26

30m (no C8 capacitor)

Qty	Value	Description	Component numbers
1	22pF	Label "220"	C5
1	30pF	Label "300"	C30
2	270pF	Label "271"	C27, 28
2	560pF	Label "561"	C25, 26

20m (no C5 or C8 capacitors)

Qty	Value	Description	Component numbers
1	30pF	Label "300"	C30
2	180pF	Label "181"	C27, 28
2	390pF	Label "391"	C25, 26

17m (no C5 or C8 capacitors)

Qty	Value	Description	Component numbers
1	30pF	Label "300"	C30
2	100pF	Label "101"	C27, 28
2	270pF	Label "271"	C25, 26

Semiconductors

Qty	Description	Component numbers
5	1N4148 diode (small red glass body)	D1, 2, 4, 5, 6
1	1N5819 diode (black plastic body)	D3
1	Si5351A, 10-pin MSOP, pre-soldered to PCB	IC1
1	ATmega328, 28-pin microcontroller	IC2
1	74ACT00N, 14-pin quad NAND gate	IC3
1	FST3253, 16-pin SOIC, pre-soldered to PCB	IC4
1	LM4562, 8-pin dual op-amp	IC5
5	NE5532, 8-pin dual op-amp (was LM4562 on kits produced before July 2022)	IC6-10
1	7805, TO220 5V voltage regulator	IC11
6	BS170 TO92 MOSFET	Q1-5, 7
1	MPS751 TO92 transistor	Q6

Inductors

Qty	Description	Component numbers
2	47uH axial molded inductor, green, colour code yellow-purple-black-silver	L5, 6

Band-specific inductors

160m

Qty	Value	Description	Component numbers
1	4.0uH	31 turns on T37-2 core (red)	L1
1	6.4uH	40 turns on T37-2 core (red)	L2
1	3.9uH	30 turns on T37-2 core (red)	L3
1	1.4uH	19 turns on T37-2 core (red)	L4
1		3+3+3+10 turns, FT50-43 (black)	T1

80m

Qty	Value	Description	Component numbers
2	2.4uH	25 turns on T37-2 core (red)	L1, L3
1	3.0uH	27 turns on T37-2 core (red)	L2
1	2.3uH	24 turns on T37-2 core (red)	L4
1		5+5+5+68 turns, T50-2 core (red)	T1

60m

Qty	Value	Description	Component numbers
2	2.1uH	23 turns on T37-2 core (red)	L1, L3
1	2.3uH	24 turns on T37-2 core (red)	L2
1	2.3uH	24 turns on T37-2 core (red)	L4
1		5+5+5+46 turns, T50-2 core (red)	T1

40m

Qty	Value	Description	Component numbers
2	1.4uH	21 turns on T37-6 core (yellow)	L1, L3
1	1.7uH	24 turns on T37-6 core (yellow)	L2
1	1.0uH	16 turns on T37-2 core (red)	L4
1		5+5+5+38 turns, T50-2 core (red)	T1

30m

Qty	Value	Description	Component numbers
2	1.1uH	19 turns on T37-6 core (yellow)	L1, L3
1	1.3uH	20 turns on T37-6 core (yellow)	L2
1	0.78uH	14 turns on T37-2 core (red)	L4
1		4+4+4+30 turns, T50-2 core (red)	T1

20m

Qty	Value	Description	Component numbers
2	0.77uH	16 turns on T37-6 core (yellow)	L1, L3
1	0.90uH	17 turns on T37-6 core (yellow)	L2
1	0.40uH	10 turns on T37-2 core (red)	L4
1		3+3+3+30 turns, T50-2 core (red)	T1

17m

Qty	Value	Description	Component numbers
2	0.55uH	13 turns on T37-6 core (yellow)	L1, L3
1	0.67uH	15 turns on T37-6 core (yellow)	L2
1	0.32uH	9 turns on T37-2 core (red)	L4
1		3+3+3+22 turns, T50-2 core (red)	T1

Miscellaneous

Qty	Value	Description	Component numbers
1	2x3-pin	Male pin header	
1	1x16-pin	Male pin header	
1	2.1mm	2.1mm DC Power barrel connector	
4	3.5mm	3.5mm stereo jack socket	
1	BNC	BNC connector socket	
1	2x12-pin	Right-angled male pin header	
1	2x5-pin	Female pin header socket	
2	2x3-pin	Female pin header socket	
2	6x6x12	6x6x12mm tactile switch button	S2, 3
2	11x7.5	7,5mm diam 11mm long button cap	For S2, 3
1	7x7mm	7x7mm locking DPDT switch	
1		Cap for locking DPDT switch	
1		Rotary encoder with shaft button	SW1
1	1602	HD44780 LCD 1602, blue backlight	
1	20MHz	HC49/4H quartz crystal	XTAL1
1	27MHz	HC49/4H quartz crystal	XTAL2
1	PCB	Main PCB	
1	PCB	Front panel PCB	
4	M3 7mm	Nylon 7mm long M3 hex spacer	
8	M3	Nylon M3 nut	
4	M3 20mm	Black steel 20mm long M3 screw	
2	Knob	Knob to fit rotary encoder and R36	
1	200cm	0.33mm diameter wire (AWG #28)	
2	M3 12mm	Steel 12mm long M3 screw	
2	M3	Steel M3 nut	

Qty	Value	Description	Component numbers
1	M3 12mm	Steel 12mm diameter M3 washer	

3. Assembly – general guidelines

Assembly of this kit is quite straightforward. But there are quite a lot of components. So please keep them methodically in trays or some convenient storage boxes, and be careful not to misplace any. The usual kit-building recommendations apply: work in a well-lit area, with peace and quiet to concentrate. **The IC (chips) and some of the other semiconductors in the kit are sensitive to static discharge. Therefore, observe Electrostatic discharge (ESD) precautions.** And I say it again: **FOLLOW THE INSTRUCTIONS!!** Don't try to be a hero and do it without instructions!

A jeweller's loupe is really useful for inspecting small components and soldered joints. You'll need a fine-tipped soldering iron too. It is good to get into the habit of inspecting every joint with the magnifying glass or jeweller's loupe (like this one I use), right after soldering. This way you can easily identify any dry joints or solder bridges, before they become a problem later on when you are trying to test the project.



You could also take photos with a mobile phone, and use the phone's zoom features to view the board in detail.

Triple check every component value and location BEFORE soldering the component! It is easy to put component leads into the wrong holes, so check, check and check again! It is difficult to de-solder and replace components, so it is much better to get them correctly installed the first time. In the event of a mistake, it is always best to detect and correct any errors as early as possible (immediately after soldering the incorrect component). Again, a reminder: removing a component and re-installing it later is often very difficult!

Please refer to the layout diagram and PCB tracks diagrams below, and follow the steps carefully.

Assembly steps will be in the order of smallest to largest components. I follow the order semiconductors, capacitors, resistors and finally all other (generally larger) components. It is probably unnecessarily thorough and complex to build the radio one stage at a time and test each stage one by one... I recommend just install everything then power up.

As per standard QRP Labs practice, the ATmega328P microcontroller has a 28-pin DIP socket in case you may wish to subsequently replace it for firmware upgrades etc. The Si5351A and FST3253 ICs are only available in surface mount packages so these are already soldered to the PCB for you, at the factory. All other components used are all leaded through-hole packages, and all are installed on the top side of the PCB.

Some people like using IC sockets, some don't. Undoubtedly there is a cost impact, of course. Personally, I believe that on average, the use of IC sockets causes more problems than it solves. They create the potential for bent pins that don't make contact properly, hidden shorts under the socket, issues with increased lead length, etc. Accordingly, the remaining ICs are soldered directly into the PCB without IC sockets. Please forgive me if you disagree.

You may find it convenient to inventory the resistors and capacitors and sort them by value, so that you can easily find the correct ones as you work through the assembly steps.

Use of a good quality soldering iron and solder is highly recommended for best results!

The following diagrams show the PCB layout and track diagrams of the front panel and main PCBs of the QCX+ kit.

Front PCB Layout:

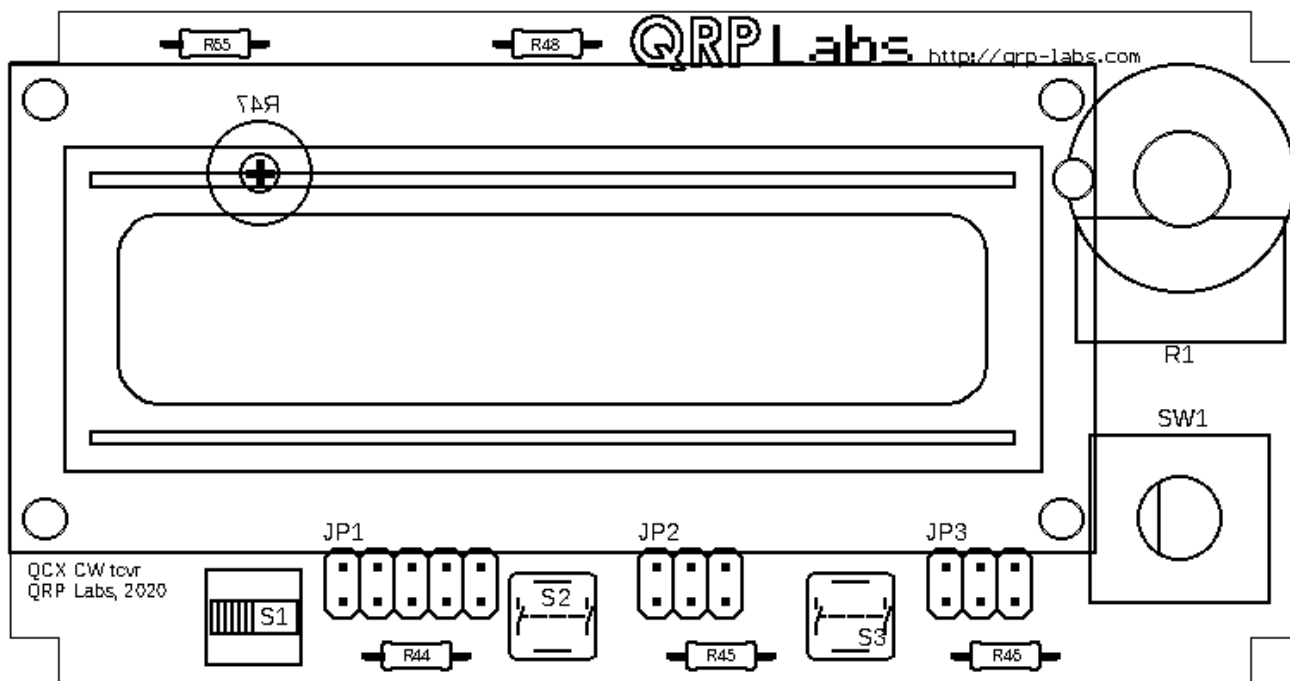

Front PCB tracks:

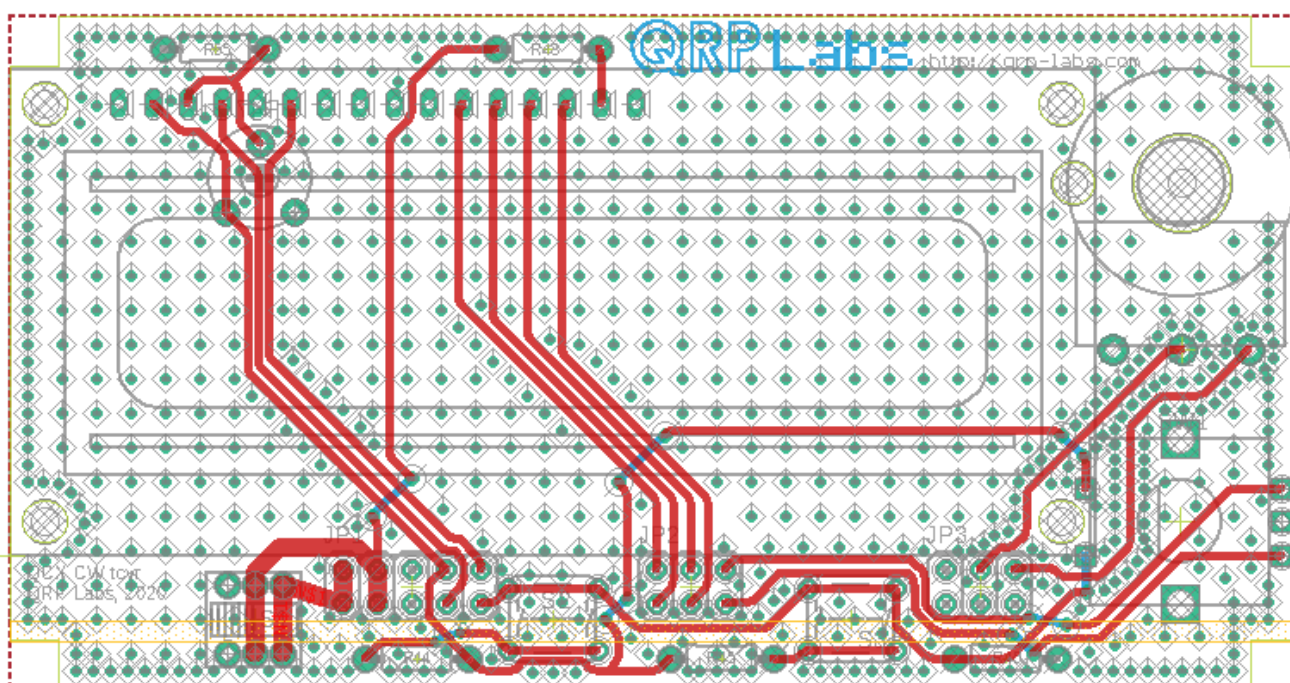

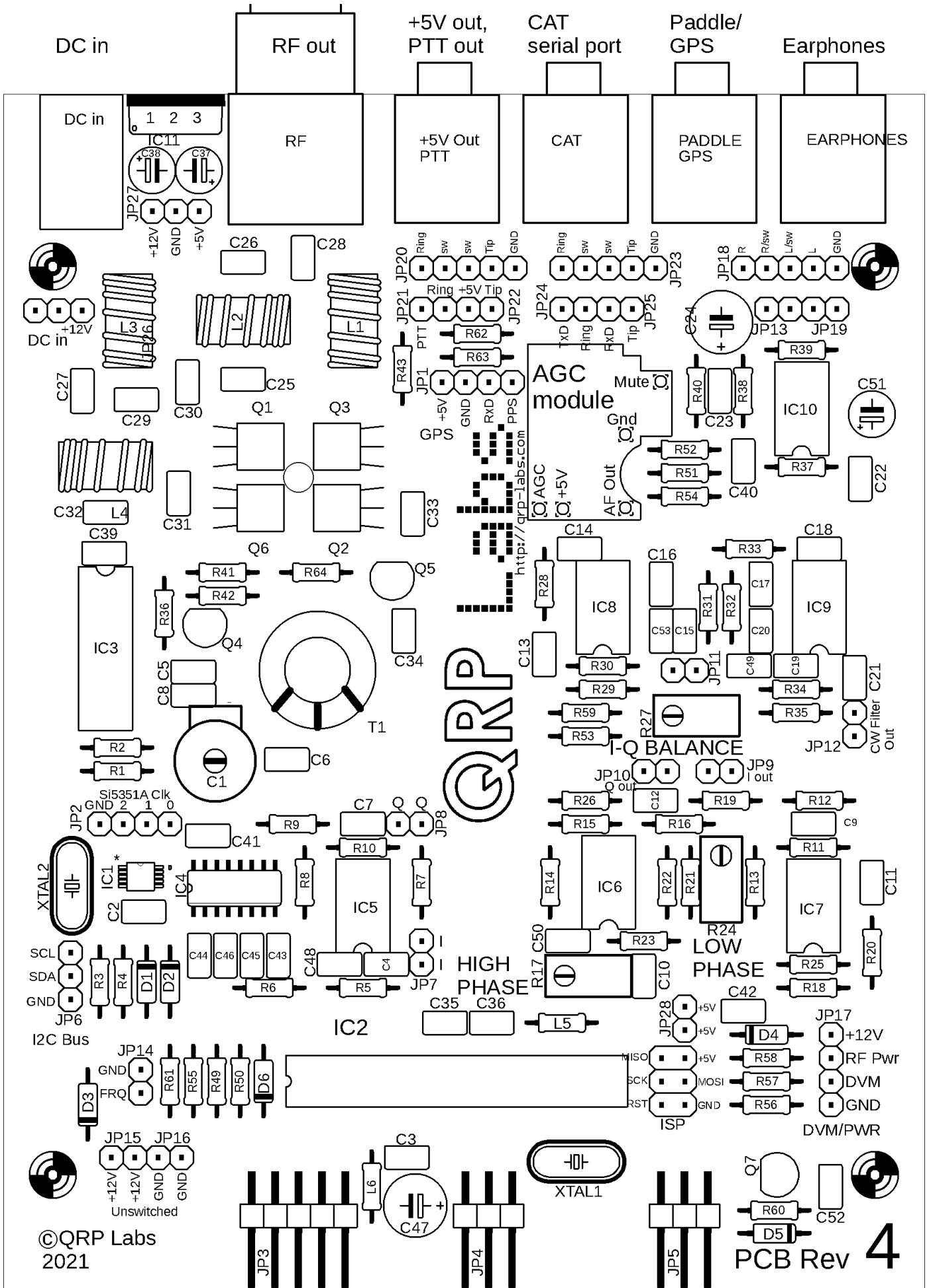

©QRP Labs
2021

PCB Rev 4

DC in RF out +5V out, PTT out CAT serial port Paddle/GPS Earphones

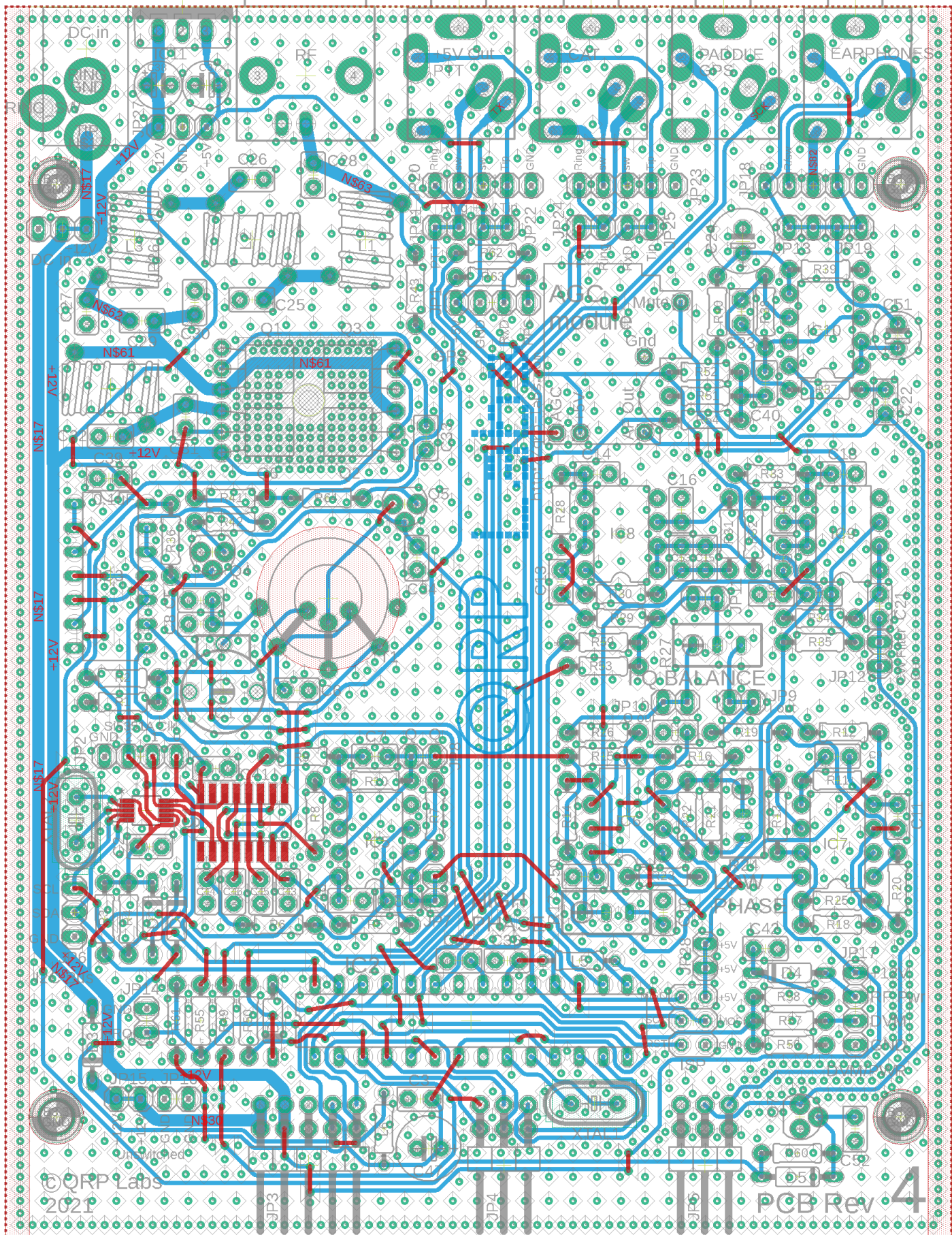

Tracks shown in BLUE are on the bottom layer. Tracks shown in RED are on the top layer. There are only two layers (nothing is hidden in the middle). Not shown in this diagram are the extensive ground-planes, on both sides of the board. Practically everything on both layers that isn't a RED or BLUE track, is ground-plane! The two ground-planes are connected at frequent intervals (not more than 0.1-inches) by vias. This is the kind of layout I have done previously for a quad-band GSM device operating at up to 1900MHz... it is probably overkill in an HF transceiver... but if you can, why not! I used to say often that you can never have too much supply line filtering and decoupling, and never have too much shielding. Both these statements don't apply so conveniently to kits as they do to homebrew projects. In a kit every decoupling capacitor has a cost in both money and PCB area (which also means more money). Shielding is even more difficult and expensive. So shielding and decoupling should be applied where needed only! But ground-plane – well that's another story. It's free, and without drawbacks – so why not, let's just put it everywhere.

All components on the main PCB are installed on the top (component side) of the PCB and soldered on the bottom (solder side) of the PCB. Some of the components of the front panel PCB are installed on the reverse side so refer to the assembly manual steps very carefully when installing the front panel components.

The PCB may be supplied with 1/4-inch / 5mm approx of blank PCB strips along one or more edges; these are part of the manufacturing process during which the PCBs are assembled on a larger panel. Simply snap the waste strip off with finger-and-thumb or pliers.

Take care when installing integrated circuits. All through-hole integrated circuits are supplied by the manufacturers with their pins bent a little wide. You need to carefully bend the rows of pins together a little, in order to fit them in the PCB holes, or in the 28-pin IC socket in the case of the ATmega328P microcontroller.

The band-specific Low Pass Filter (LPF) parts are supplied in a separate LPF kit bag.

In the construction for some bands, not all of the capacitors supplied in the kit are used. Do not be alarmed if you have a few components left over at the end!

Wind the L1-3 inductors with the enamelled copper wire supplied in the LPF kit bag. Wind the other inductors (L4 and transformer T1) using the wire supplied in the main kit bag.

The component colour coding of the layout diagram at every step of the assembly instructions is as follows (kind of: components past, present and future):

- Components shaded grey have already been installed
- Components shaded red are the ones being installed in the current assembly step
- Components shaded white are the ones which have not yet been installed

The following photographs show the final assembly. You can keep these photographs in mind when assembling the kit, they will give you some idea of how the kit fits together and help avoid assembly errors.

Capacitor pin spacing

In general, the capacitors supplied in the kit have 2.54mm (0.1-inch) pin spacing. From time to time, a supplier shortage may require us to change a capacitor to 5.08mm (0.2-inch). If you have a capacitor with the 0.2-inch spacing do not worry, this is not an abnormal problem; just bend the wires inwards as shown (right) and proceed regardless.



Main board:

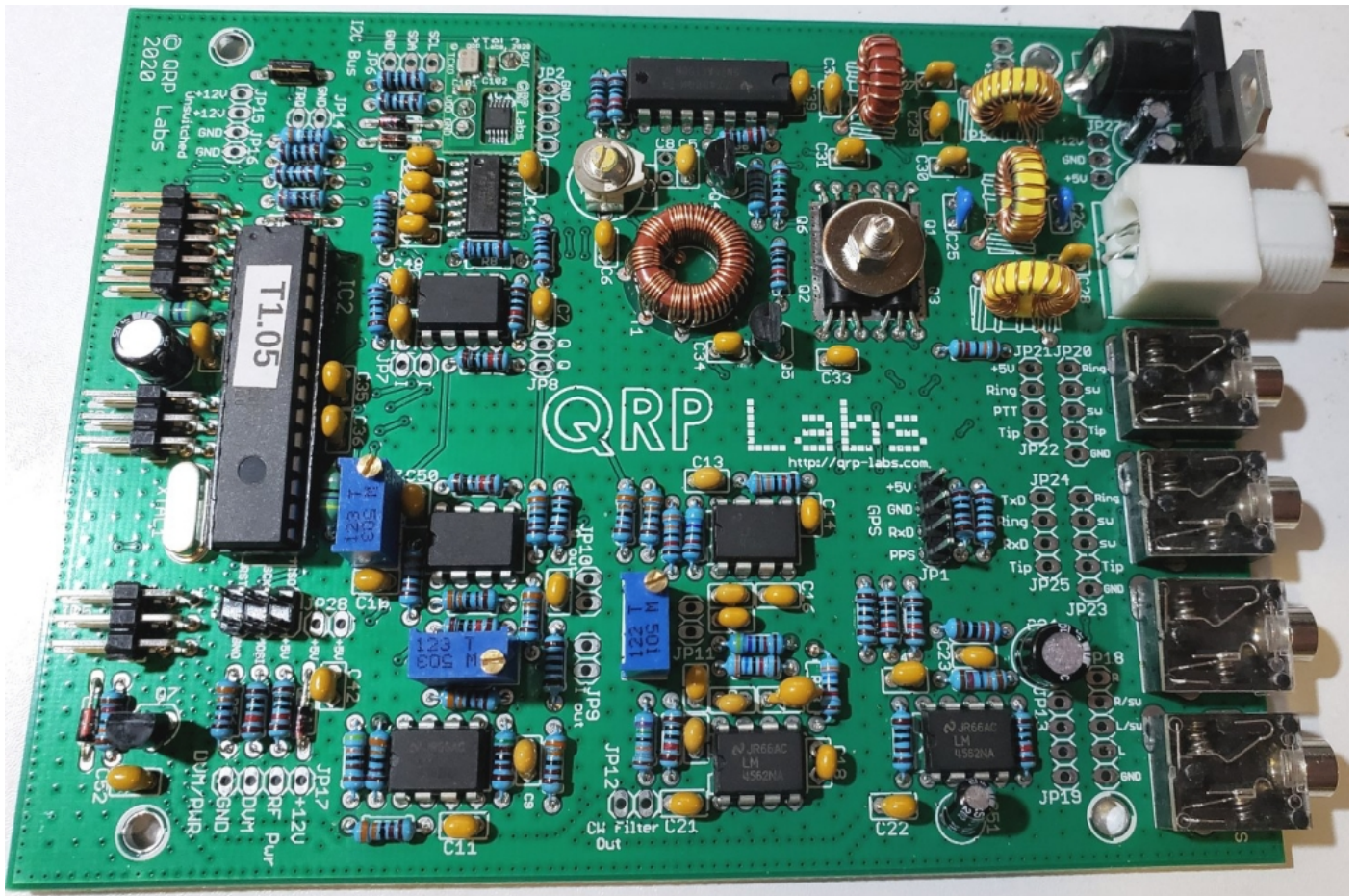

Front panel board:

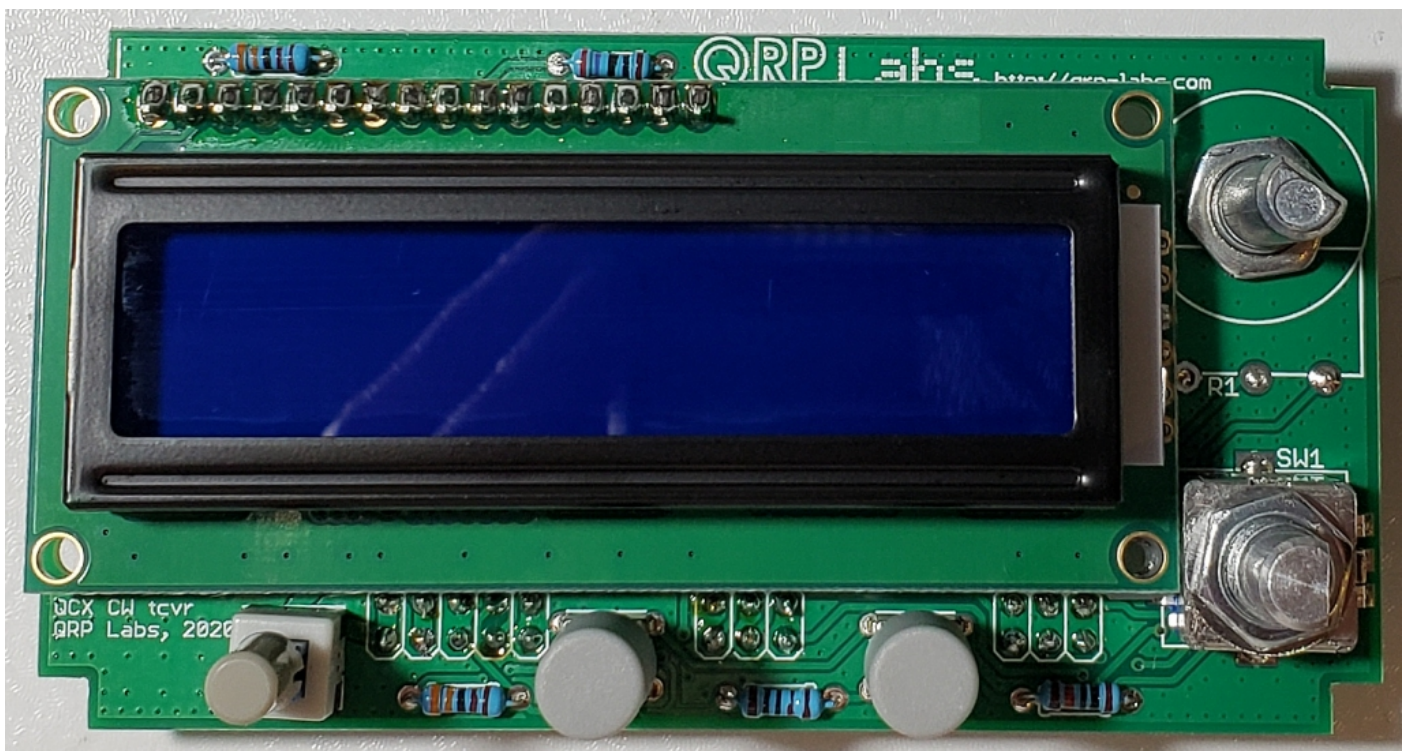

3.1 Inventory parts

Refer to parts list in section 2. The following photographs are to aid component identification. The resistors and capacitors are omitted. Si5351A and FST3253 are already soldered to the board.

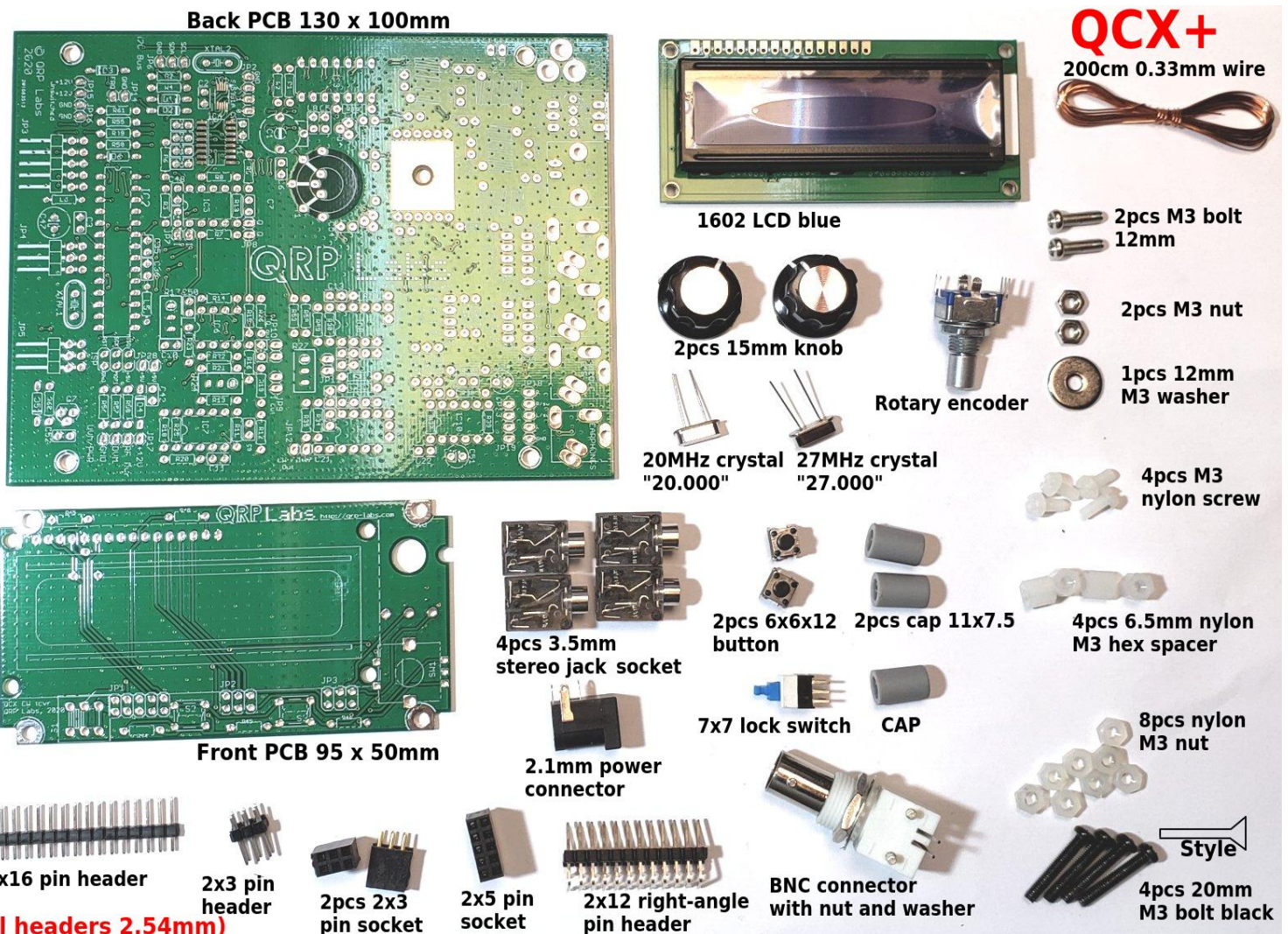
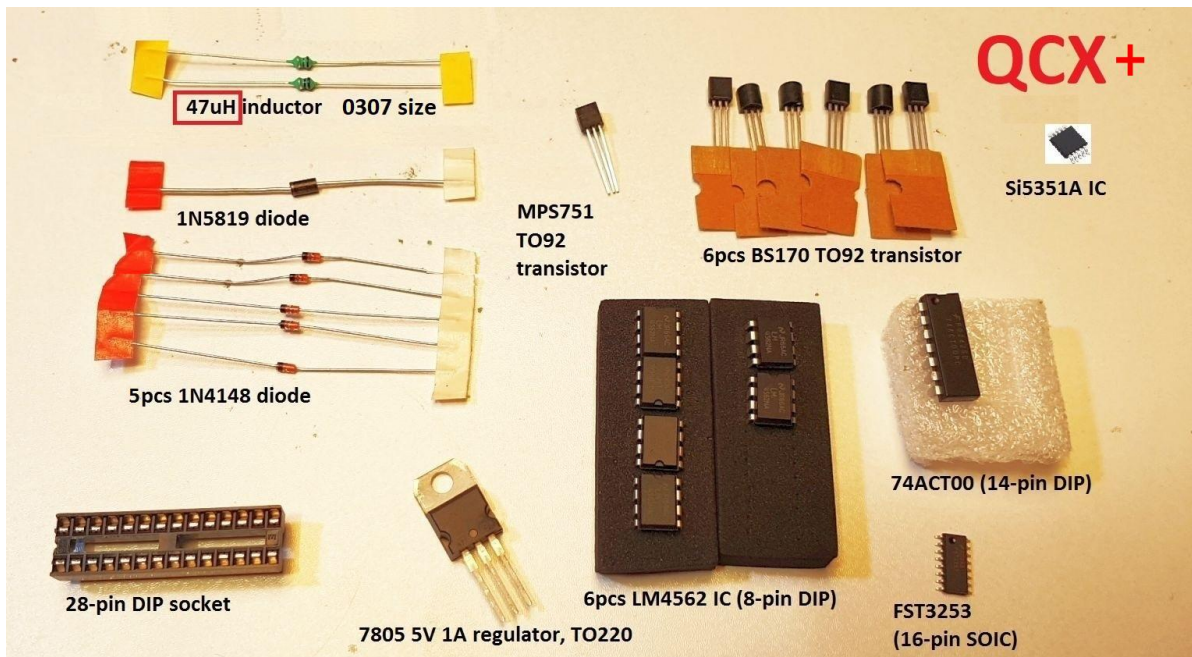

3.2 Wind and install transformer T1

This is the only really tricky piece of the assembly: the receiver input transformer T1. Follow these instructions carefully, it is tricky but quite feasible if you go step by step.

Note that this installation used to be done later in the manual. It has been moved to the FIRST step because it is easiest to do the installation when there are no other components nearby.

In the end, you are going to end up with an installed transformer which hopefully looks something like the photo (right, shows 40m version).

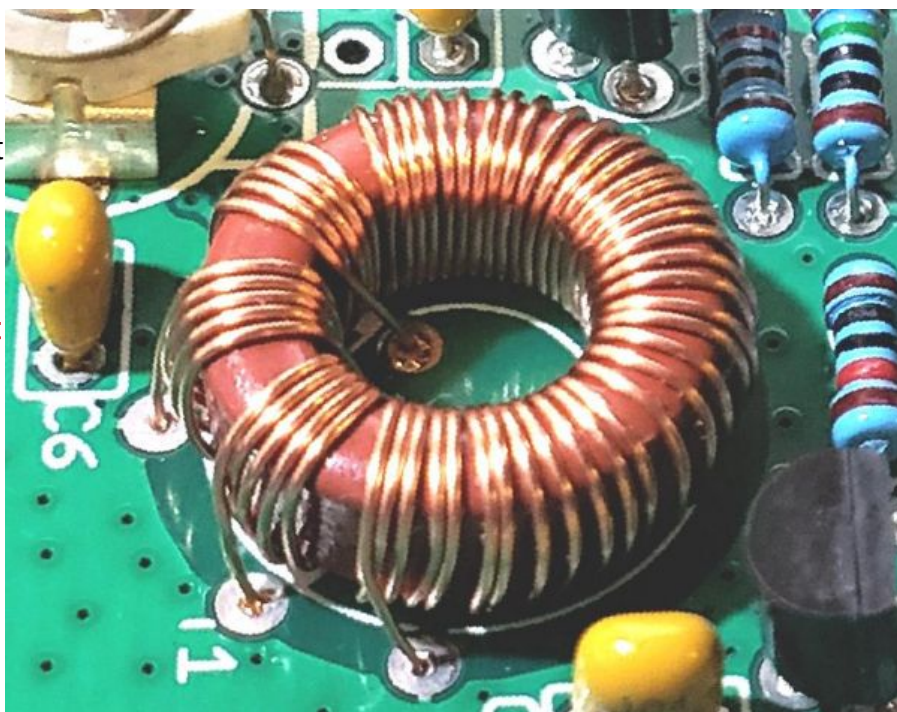

This transformer has FOUR windings. Three identical short windings, and one long winding. There are therefore eight wire ends, which must all be soldered into the correct holes on the PCB, and with the enamel properly removed.

Here are two diagrams which enumerate each of the windings, wire endings and holes on the PCB, on both the layout diagram and on the circuit (schematic) diagram. It should help to explain diagrammatically which wires must go where.

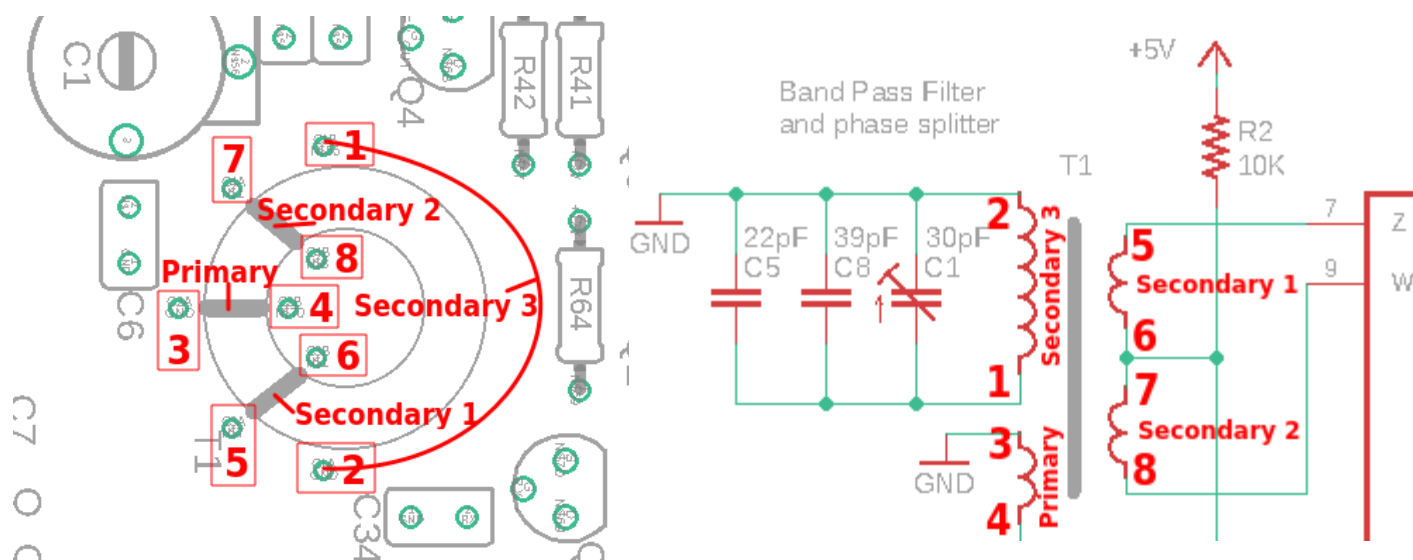

On the following page is a diagram hand-drawn by Ed WA4MZS (thanks Ed!) which may also clarify the construction and installation of T1.

The four windings on T1 must all be in the same “sense”. There are two ways to wind toroids. You might call them left-handed and right-handed; clockwise and counter-clockwise; whether the wire goes through the toroid from top to bottom, or from bottom to top. Whatever you call it, all the four windings have to be the same, to be sure to get the phasing to the quadrature sampling detector correct.

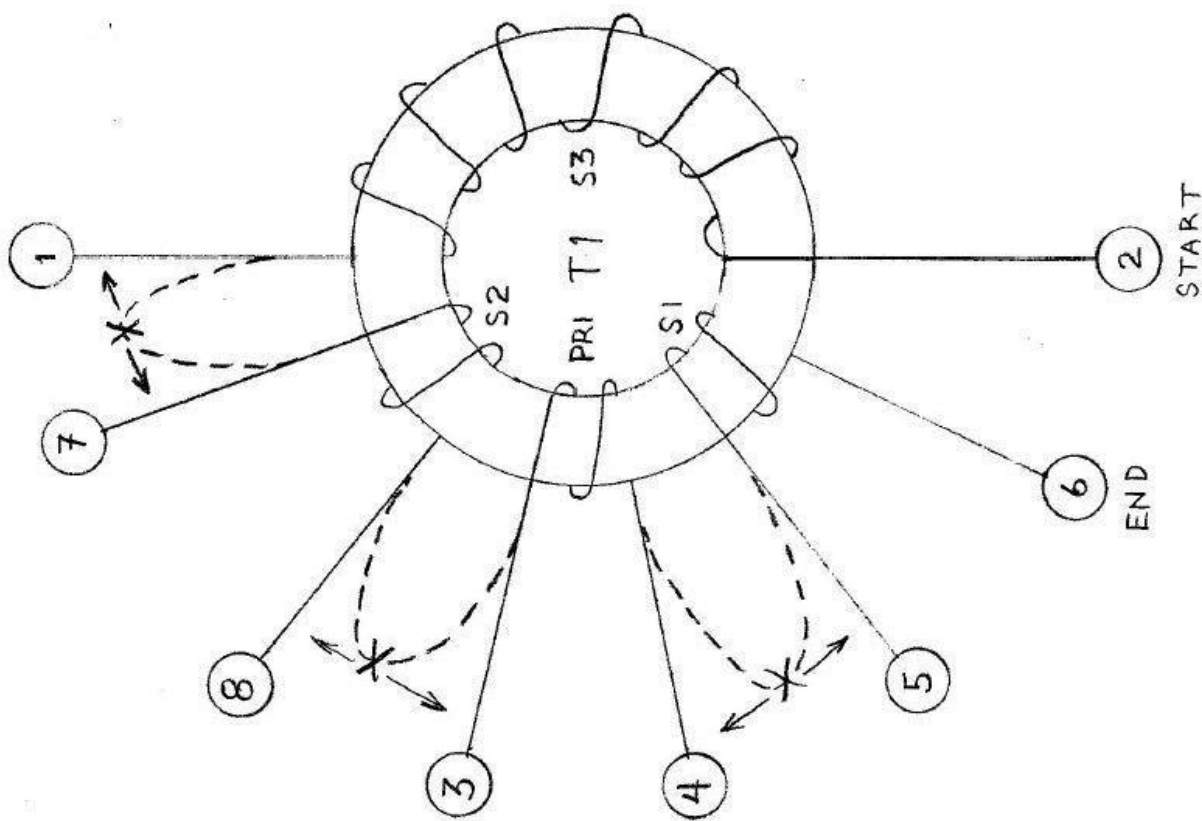
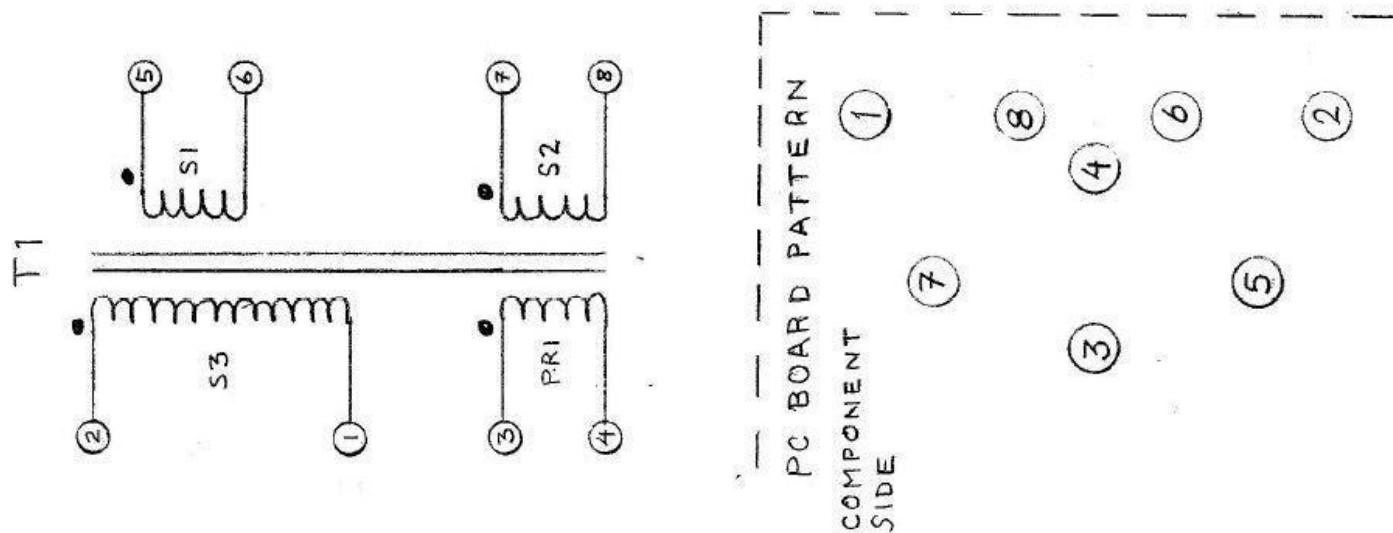

BAND	PRI	S1	S2	S3
80m	5T	5T	5T	68T
60m	5T	5T	5T	46T
40m	5T	5T	5T	38T
30m	4T	4T	4T	30T
20m	3T	3T	3T	30T
17m	3T	3T	3T	22T

CORE = T50-2

WIND w/ #28 ENAM.
(0.33 mm)

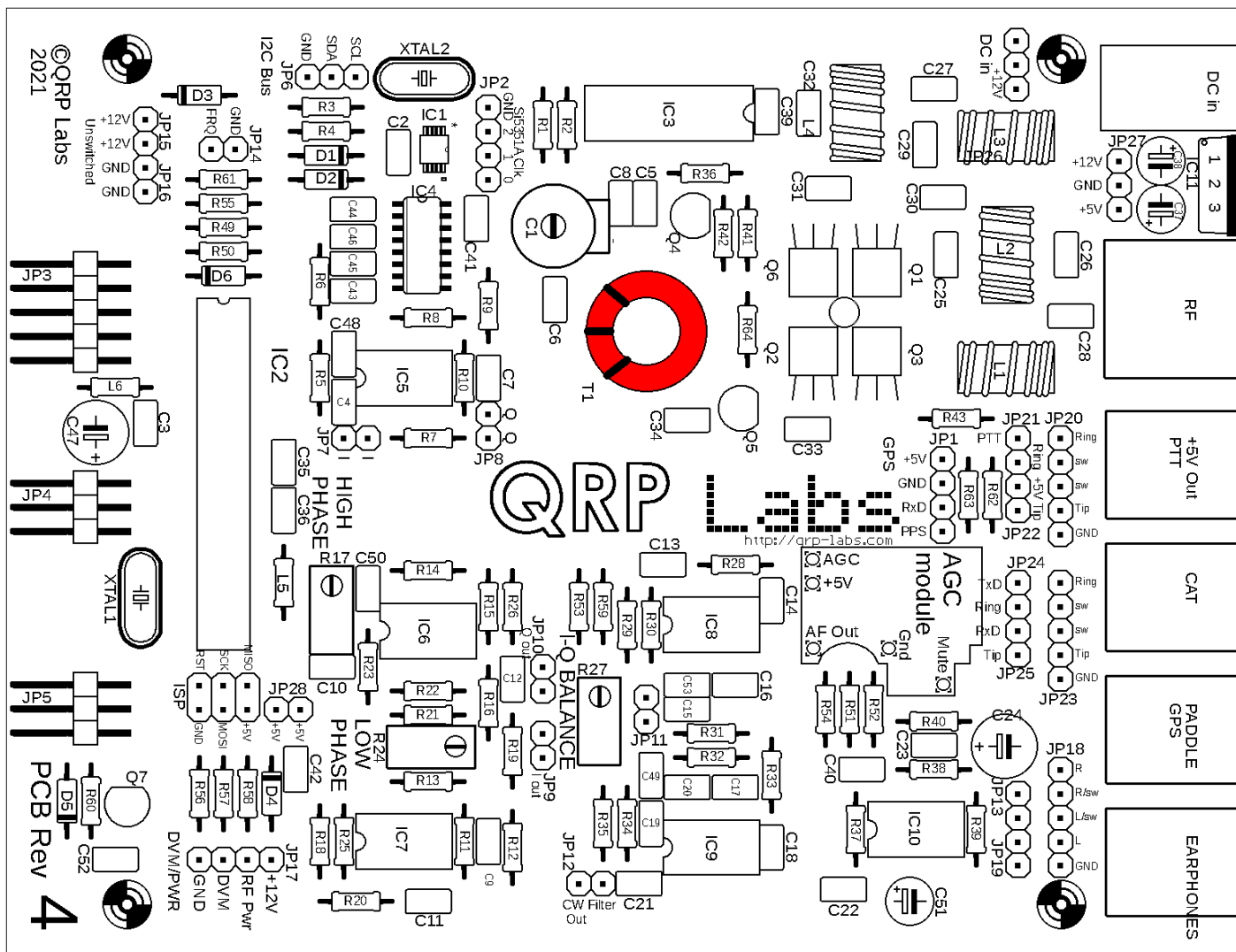

The number of turns in each winding depends on the band you are building the kit for. Refer to the following table. **For convenience, the remainder of the instructions in this section refer to the 40m version (38 + 5 + 5 + 5 turns).**

But MAKE SURE you wind the correct number of turns and toroid for your band!

Band	Toroid	Primary	Secondary	Secondary	Secondary
			1	2	3
160m	FT50-43	3	3	3	10
80m	T50-2	5	5	5	68
60m	T50-2	5	5	5	46
40m	T50-2	5	5	5	38
30m	T50-2	4	4	4	30
20m	T50-2	3	3	3	30
17m	T50-2	3	3	3	22

Note for 80m and 60m versions: the toroid ring is not large enough to neatly hold all of those turns in a single flat tidy winding. The large secondary winding WILL end up looking messy, with overlaps in some places. You should try to ensure any overlaps turns are evenly spaced throughout the winding! Do not try to wind one neat layer, then wind the remaining turns as an additional neat layer on top of that. Just go with the messy overlapping turns and don't worry about it: everything will work fine, regardless.

There is a suggested modified way of winding the turns for 60/80m versions, which may make it easier; see <http://www.qrp-labs.com/qcx/qcxmods.html#80m>

In all cases, there is one long secondary winding, and three other short identical windings. To make things easier, we will wind all windings together in one go, this will guarantee that the “sense” of each winding will be the same. At the intended breaks between the windings, we will leave large loops of wire, that we can later cut one by one to make sure the wires go in the correct holes.

There are a lot of steps listed below but in reality, it is easier DOING it than it is writing instructions how to do it. Take it patiently, step by step:

- 1) Hold the toroid between thumb and finger, and thread the first turn of the wire through from top to bottom. Leave about 3cm of wire at the free end.
- 2) Apply tension to the wire after each pass through the centre hole, to try to keep the windings tight and even. The wire turns should sit neatly side-by-side on the toroid, without overlapping.
- 3) Grip the toroid between thumb and finger as you wind.

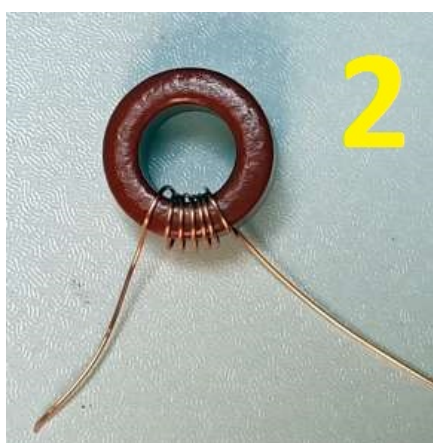
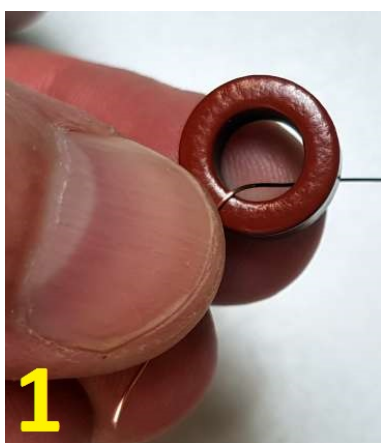

- 4) When you have completed 38 turns, pass the wire through the hole for the 39th turn but leave a large loop of wire between the 38th and 39th, without pulling it tight.
- 5) Grip the toroid and wound turns tightly between thumb and finger, and with the other hand apply some twists the wire loop, tight next to the toroid.
- 6) The result is a wire loop after 38 turns, as shown.

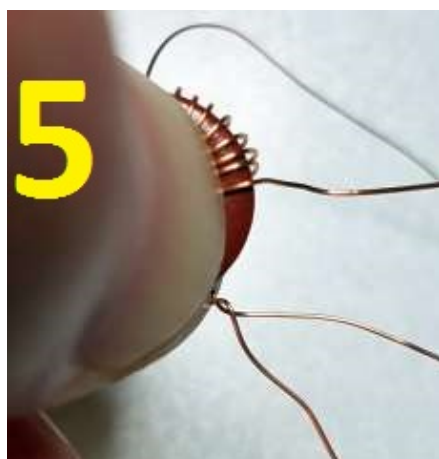
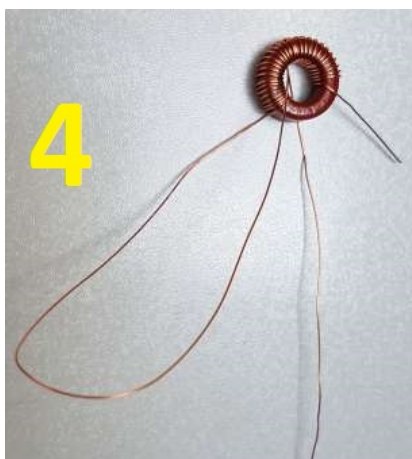

- 7) Do the same thing for two more loops, which are between the 43rd and 44th turns, and 48th and 49th turns respectively. It is easy to lose count. An easy way is after step 6, pass the wire through the hole 5 more times, and on the 5th one, make a loop. Similarly count

five more and make a loop on the fifth. Then finally five more turns to complete the toroid's 53 windings. Count the windings to make sure you have 53. When you are sure everything is fine, cut the wire leaving about 3cm of wire free at the end.

- 8) Thread the original start of your winding (from step 1) into hole 2 in the diagram. Thread the final end of your winding (from step 7) into hole 6.
- 9) Twist these two wires under the board to keep the toroid in place while you deal with the remaining wires.

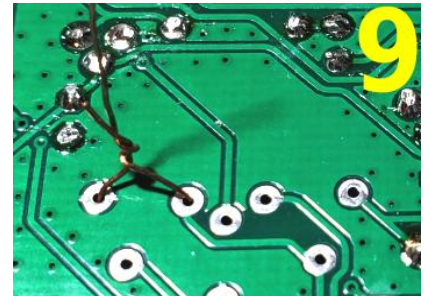
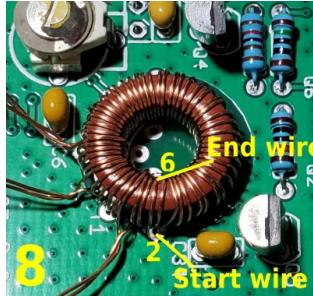

- 10) Now cut the 3rd loop (the one nearest the end of the winding work), and un-twist the twisted section you made near the toroid body.
- 11) When you cut the loop, you therefore created two wires. One of these came over the top of the toroid, and you can easily verify that this is the one which has five turns through the toroid then passes through hole 6. So, insert this wire into hole 5. Once again to be clear: you should now have a winding of five turns (which is labelled "secondary 1", above), with one end inserted into hole 6 and one end inserted into hole 5. The other wire came from UNDER the toroid. You must push this wire towards the toroid and pull it out through the centre hole of the toroid. Now thread it through hole 4. Under the board, twist the two new ends of wire together to keep them in place.

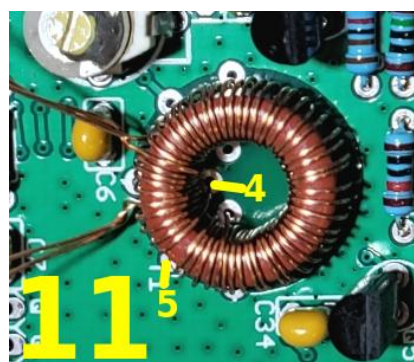
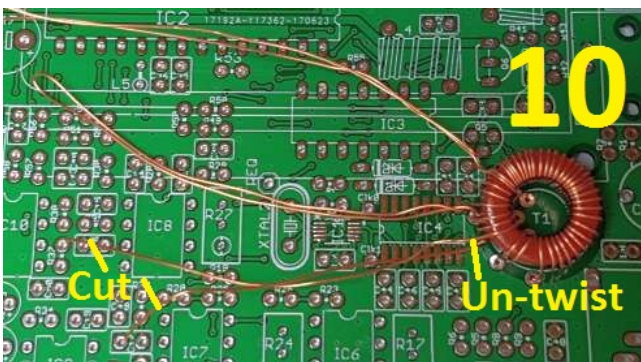

- 12) Next cut the 2nd loop, and un-twist the twisted section near the toroid body.



- 13) Similar to step 11; the wire which came over the toroid body has five turns then goes into hole 4, which you did in step 11. Insert this wire-end into hole 3. The other wire end that came from under the toroid body should be gently pushed toward the toroid, and pulled up through the centre hole of the toroid. Insert that wire end into

hole 8. So now you have the “primary” winding consisting of five turns, between holes 3 and 4.

Twist the two new wires under the board again, to keep everything in place.

- 14) Finally, cut and un-twist the loop which you created first, which was between the 38th and 39th turns of the toroid winding. Push the wire which came over the toroid body, into hole 7. Now you have five turns of wire, which make up “secondary 2”, between holes 7 and 8.

- 15) The last wire came from under the toroid body when you cut the loop; this wire is the other end of the 38 turns “secondary 3” winding, so insert it into hole 1. It is already near to hole 1 and you don’t need to push it under the toroid body as you did in previous steps.

Take a moment now to review the situation. You should be able to identify the four windings of T1, and squeeze them together neatly as in the photo, to verify that each end of the 3-turn windings goes into the correct holes.

- 16) Under the PCB, you should have three pairs of twisted wires, and one pair (that you installed last), un-twisted.

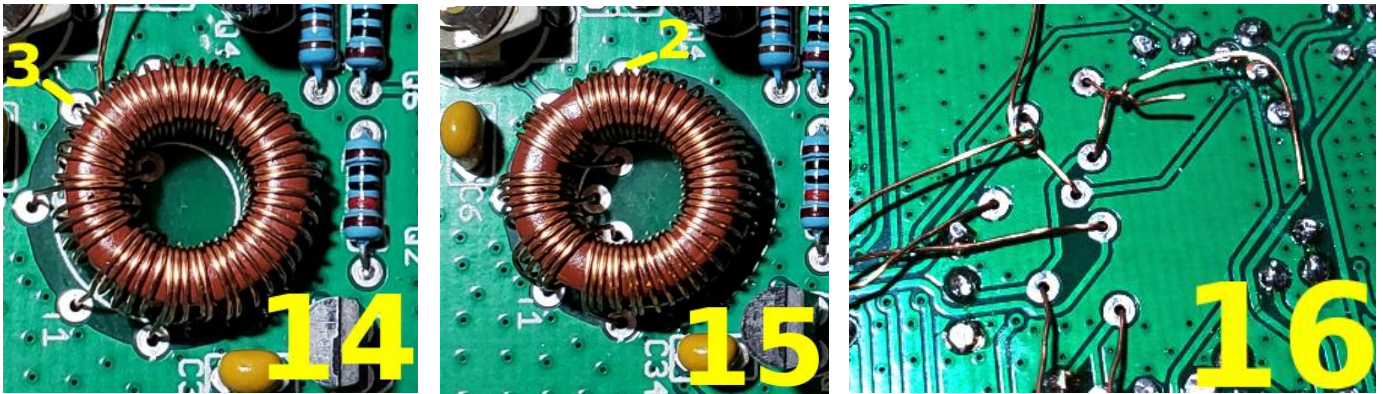

- 17) Now you can solder the eight connections under the PCB. I recommend doing one pair of wires at a time; this way, the other wires will hold the toroid in place and stop it falling out. Start with the two un-twisted wires. Pull each wire tight, bend it over at about 45-degrees, and cut it 1-2mm away from the PCB surface. Having bent the wire prevents it from falling out. Now solder the wire. Remember to hold the soldering iron to the joint for 10 seconds or so, to allow the enamel insulation to burn off.

Repeat for all the other wires, one pair at a time, until all eight are soldered. If you have a DVM, check for DC continuity (zero ohms resistance) across each winding. If you do not get the expected continuity, then it means either

- a) you have not managed to scrape or burn away the enamel insulation properly so there is no electrical connection AND/OR
- b) you put the wires into incorrect holes AND/OR
- c) your expectation is wrong because you have not identified which pad on the PCB is labelled 1-8 in the diagram.

- 18) The final picture (18) shows the toroid installation completed.

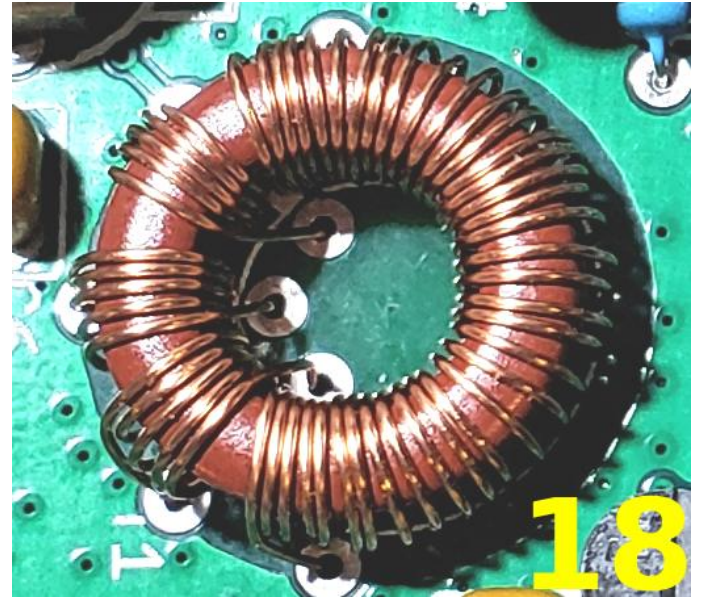
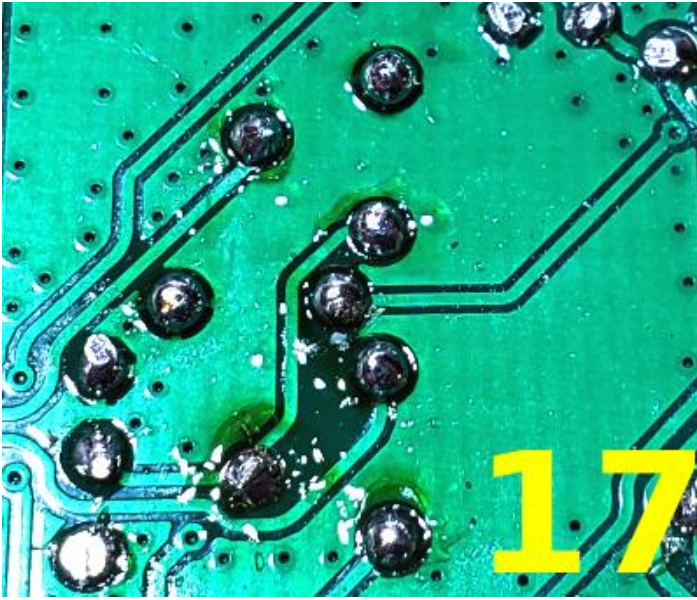

3.3 Install IC2 socket

Install the 28-pin IC socket for IC2. Take care to match the dimple on the socket, with the dimple on the PCB silkscreen. It is critical to insert the microcontroller with the correct orientation. Lining up the dimple on the PCB silkscreen, socket and actual IC is the best way to avoid confusion and potential error.

I recommend soldering one pin at each diagonal, for example pins 1 and 15. You can then check that the IC socket is seated firmly on the PCB, and correct any issues easily. Once all the pins are soldered it will be difficult, if not impossible, to change anything. When you are happy with the position of the socket, proceed with soldering the other 26 pins.

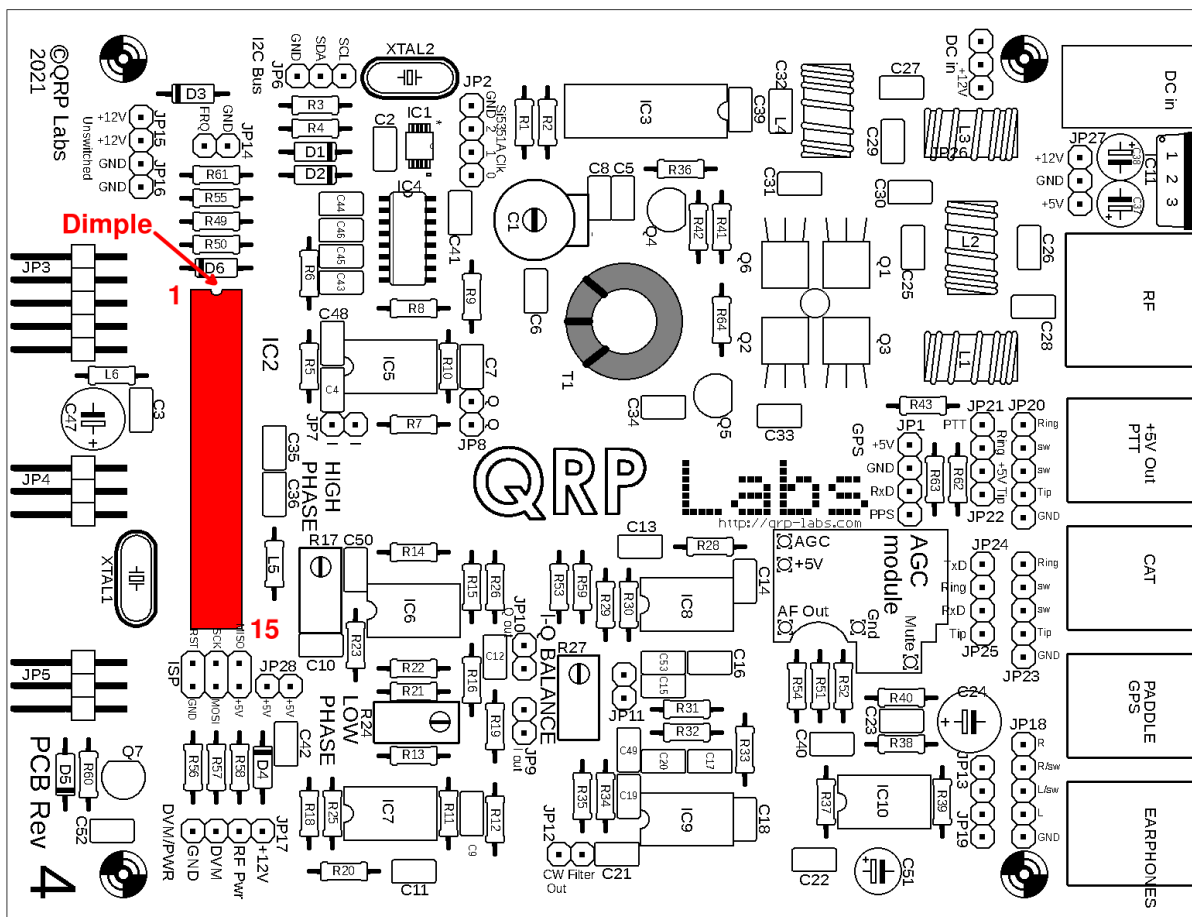

3.4 Install DIP integrated circuits IC3, IC5-10

In the same way, install the Dual-Inline-Package integrated circuits IC3 and IC5-10. We install these now because they have more pins than all the passive components (resistors, capacitors etc) and it is easiest to reach and install the ICs properly when they are alone on the board. IC3 is the only 14-pin DIP chip. **For IC5-IC10, there are six 8-pin ICs supplied; if there is a paper in your kit with instructions for how to identify IC5 and IC10 separately from IC6-9, please pay CAREFUL attention and follow it!**

Kits supplied from July 2022 onward: IC5 must be LM4562, IC6-10 are NE5532. Be careful not to mix these up!

Electrostatic Discharge (ESD) precautions should be observed though personally I do not think it is necessary to get crazily paranoid about this. Don't wear 100% nylon clothing and dance around on a nylon carpet etc to build up static charge! But I don't go to the other extreme of earth mats, earthed wrist bands etc.

It IS absolutely critical to align the IC's properly! Be very careful to check and double-check and even triple-check that the dimple in each IC package is aligned with the dimple in the silkscreen print on the PCB (and the layout diagram). **The dimples of all the 8-pin ICs point to the left (in the orientation of the diagram below); the dimple of the 14-pin IC3, points to the right. This is VERY IMPORTANT!**

It is normal to need to slightly squeeze the rows of pins inwards to fit in the holes on the PCB. IC manufacturers always supply leaded (through-hole) ICs with the pins a little too wide-spaced.

As before, I find it useful to solder initially two pins at diagonal opposites of the chip, then check that the chip is nicely seated evenly on the board, before soldering the other pins.

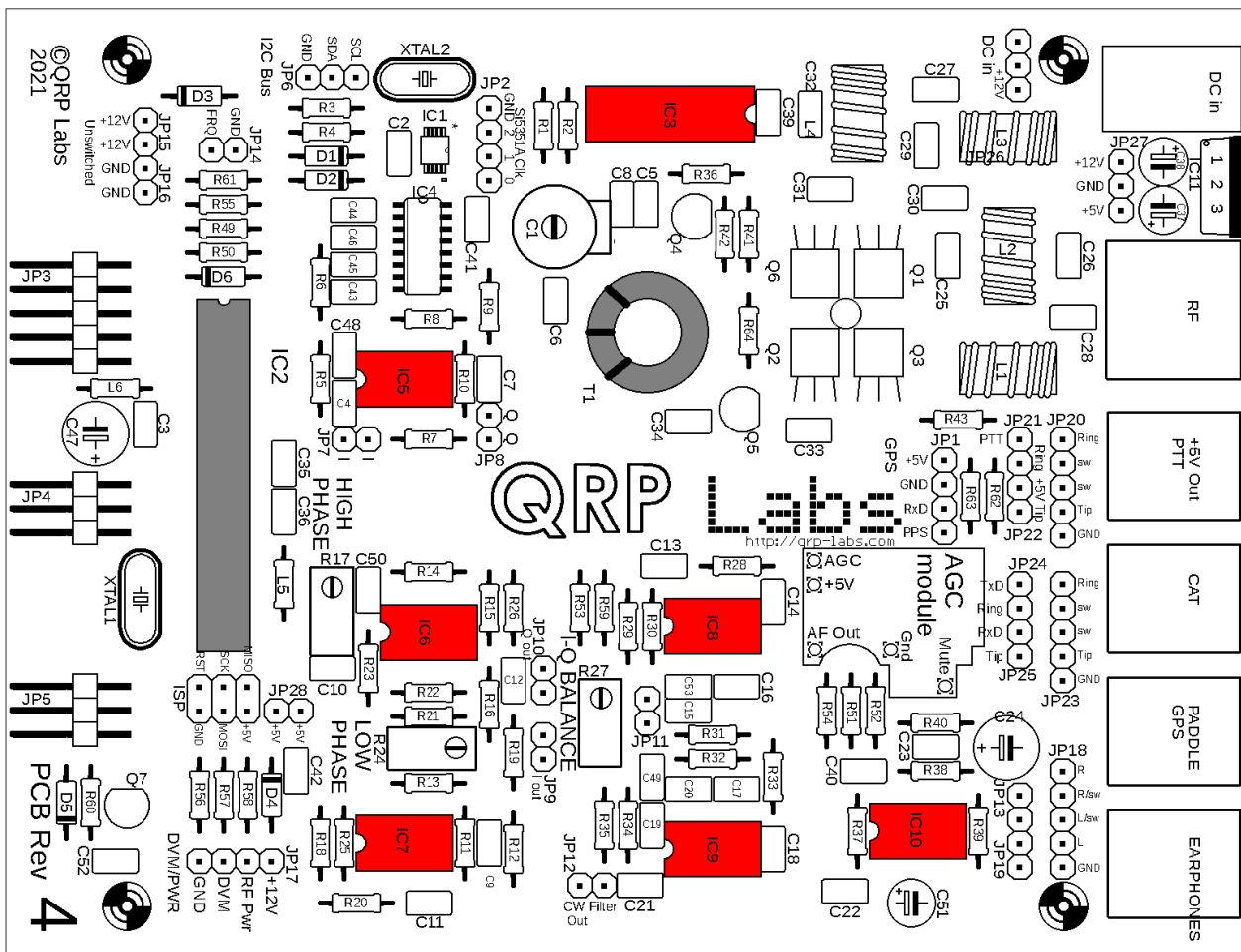

3.5 Install all 100nF (0.1uF, “104”) capacitors

There are 16 100nF (0.1uF) capacitors, these have the code “104” written on them. Be sure to identify the correct capacitors, using a magnifying glass or jeweller’s loupe. These capacitors are C2, C3, C6, C12, C29, C32, C34, C35, C36, C39, C40, C41, C48, C49, C50 and C52. Place each in the correct position on the board, and slightly bend the legs outwards at about 30-degree angle so that they stay in place. Then solder the wires, and trim the excess wire length with wire cutters.

It does not matter which way round the capacitors are installed. However, it is very good practice to install them all with the capacitor label facing in the same direction. For example, ensure all the “104” labels face to the front, or to the right (depending which way the capacitor is orientated on the PCB). This makes it much easier to inspect the PCB assembly later.

Take particular care soldering wires which connect to the ground plane. Despite the “thermals” (a ground pad is connected to the ground plane by four thin traces, not a continuous ground plane, to make soldering easier), the heat dissipation is still more, and it can be harder to make a good joint.

Note that if you are going to install the TCXO module option, DO NOT install capacitor C2. Skip this capacitor! This is circled in ORANGE below.

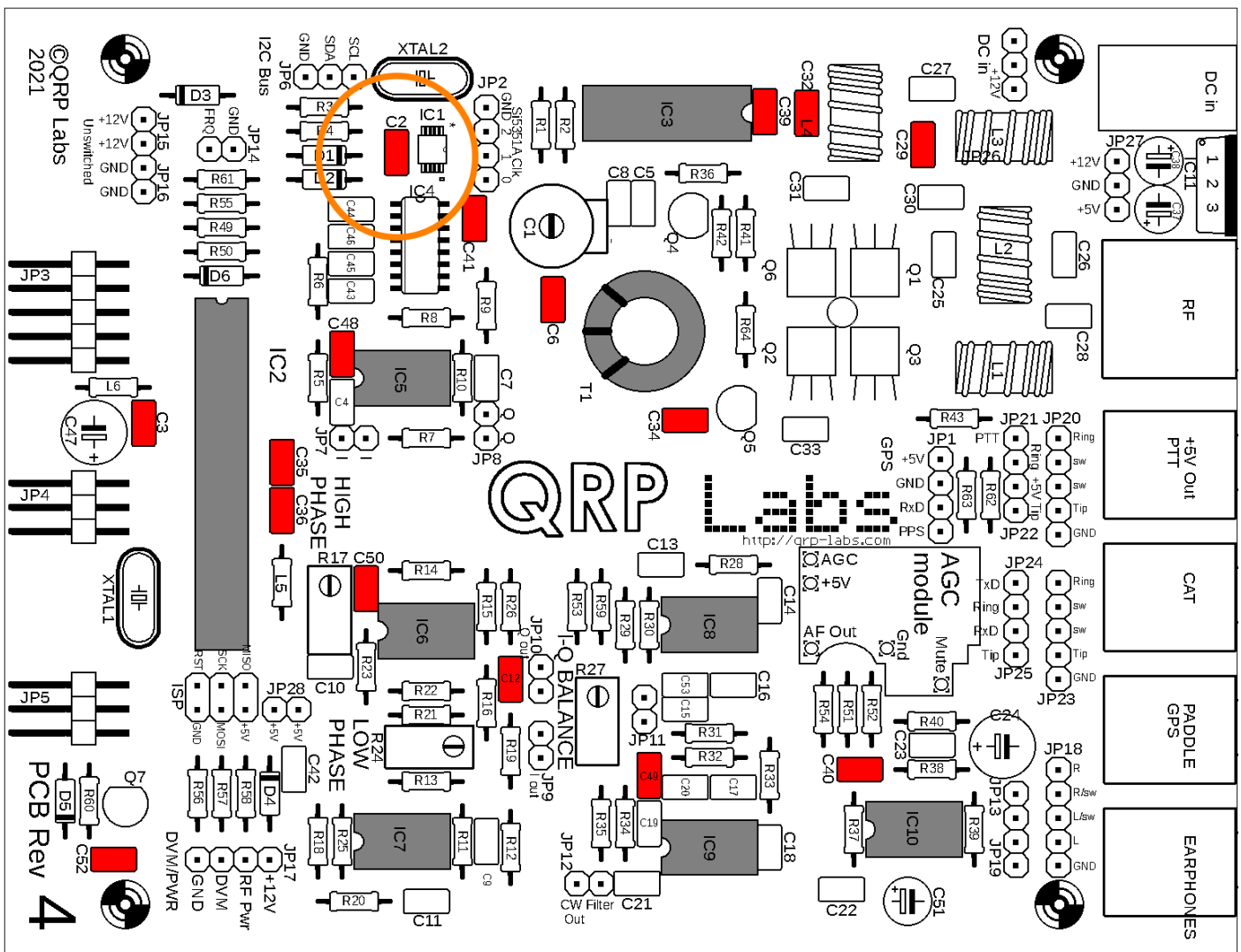

3.6 Install all 470nF, “474” capacitors

The 470nF capacitors are labelled “474”, and are capacitors C11, C43, C44, C45 and C46.

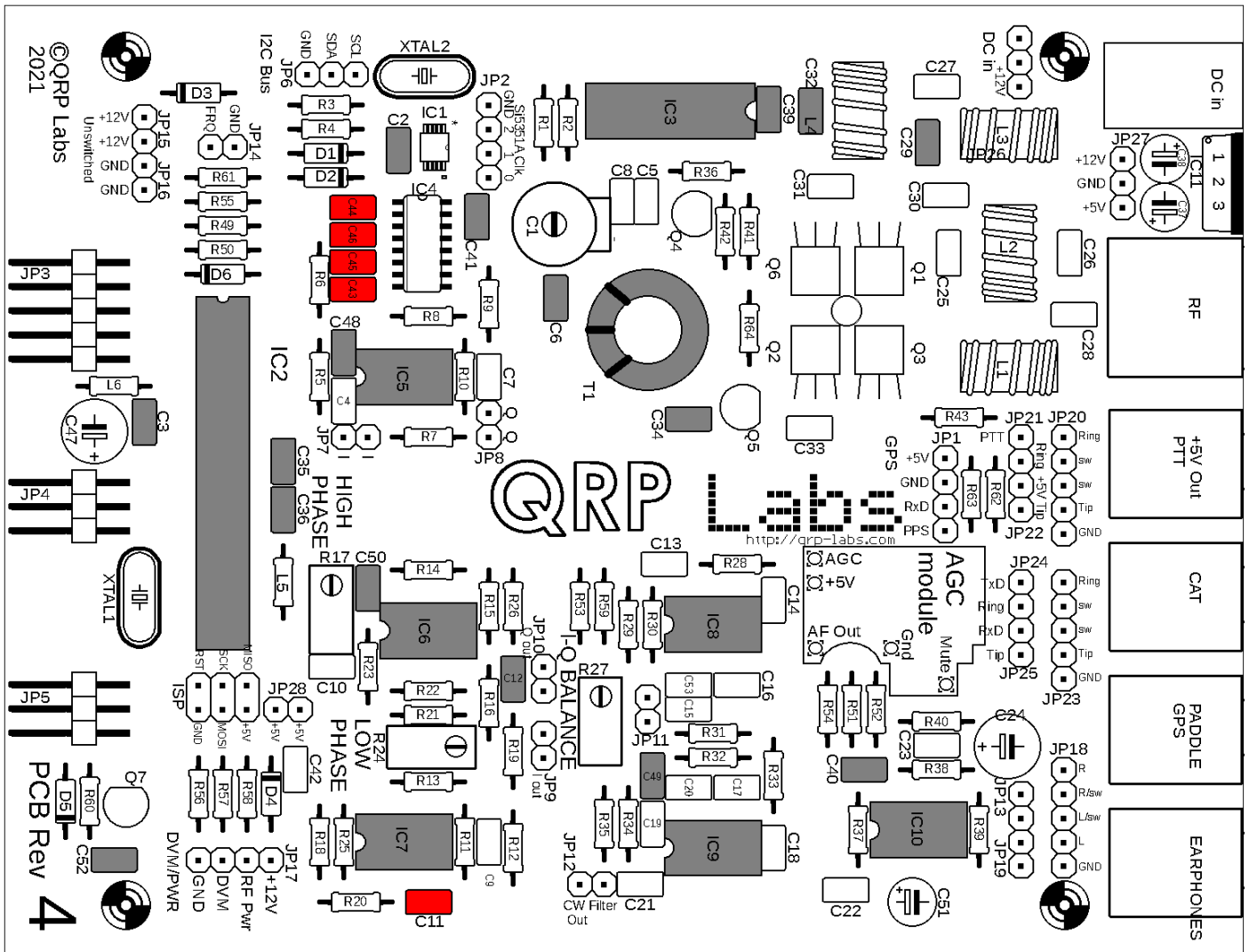

3.7 Install all 1nF, “102” capacitors

The 1nF capacitors are labelled “102” and are capacitors C14, C16, C18, C23 and C33.

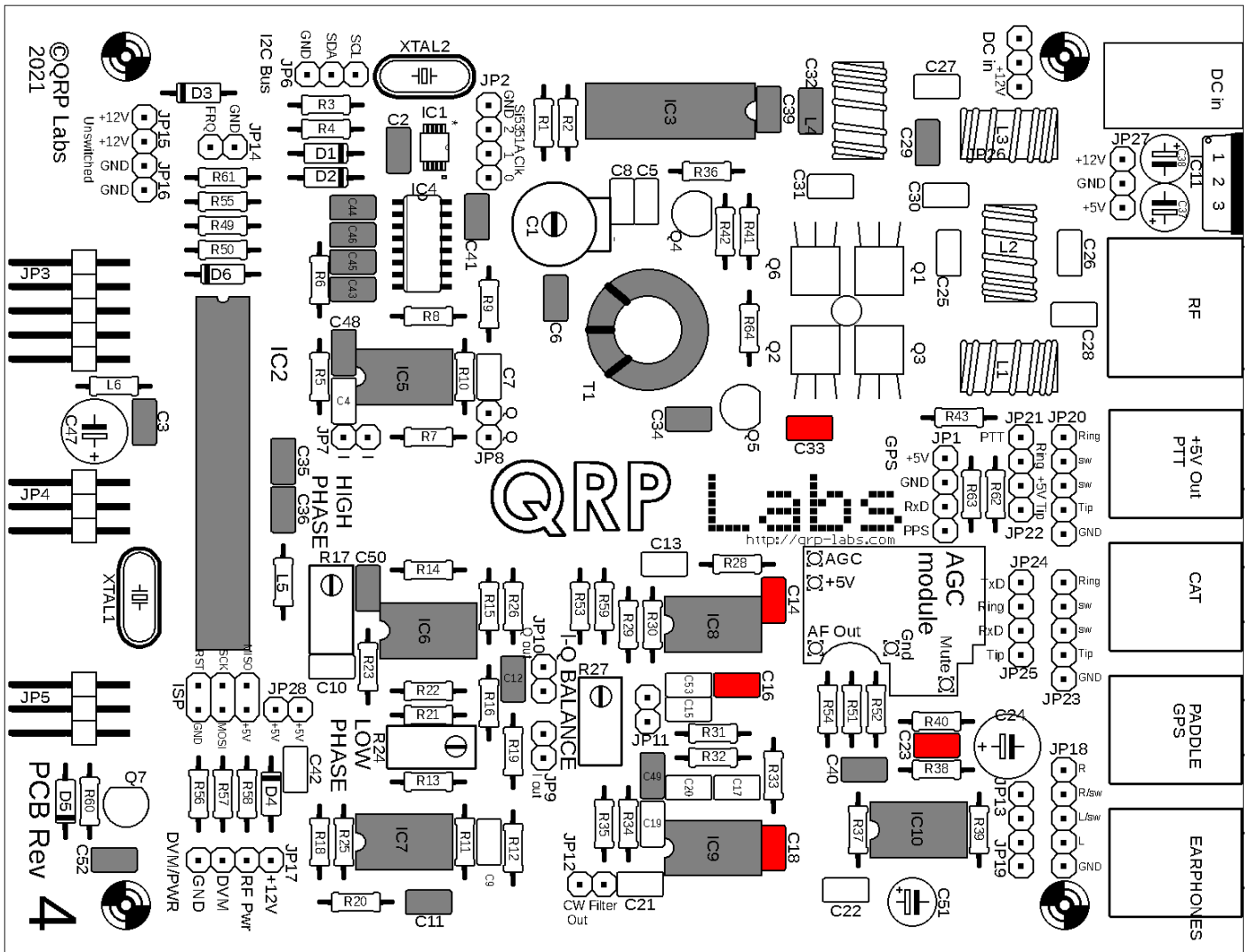

3.8 Install all 10nF, “103” capacitors

The 10nF capacitors are labelled “103” and are capacitors C4, C7, C10 and C42.

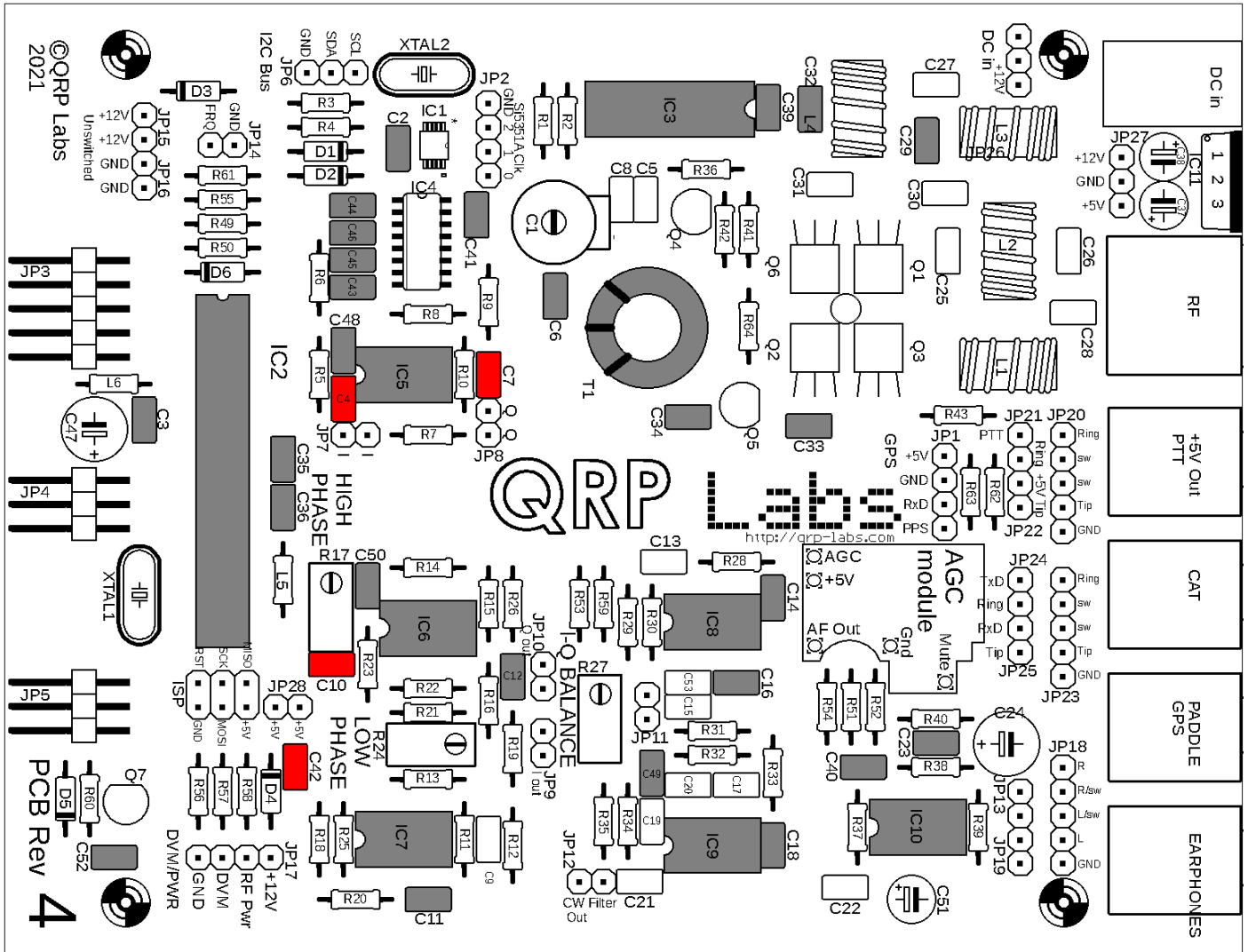

3.11 Install 2.2nF, “222” capacitors

The 2.2nF capacitors are labelled “222” and are C19 and C20.

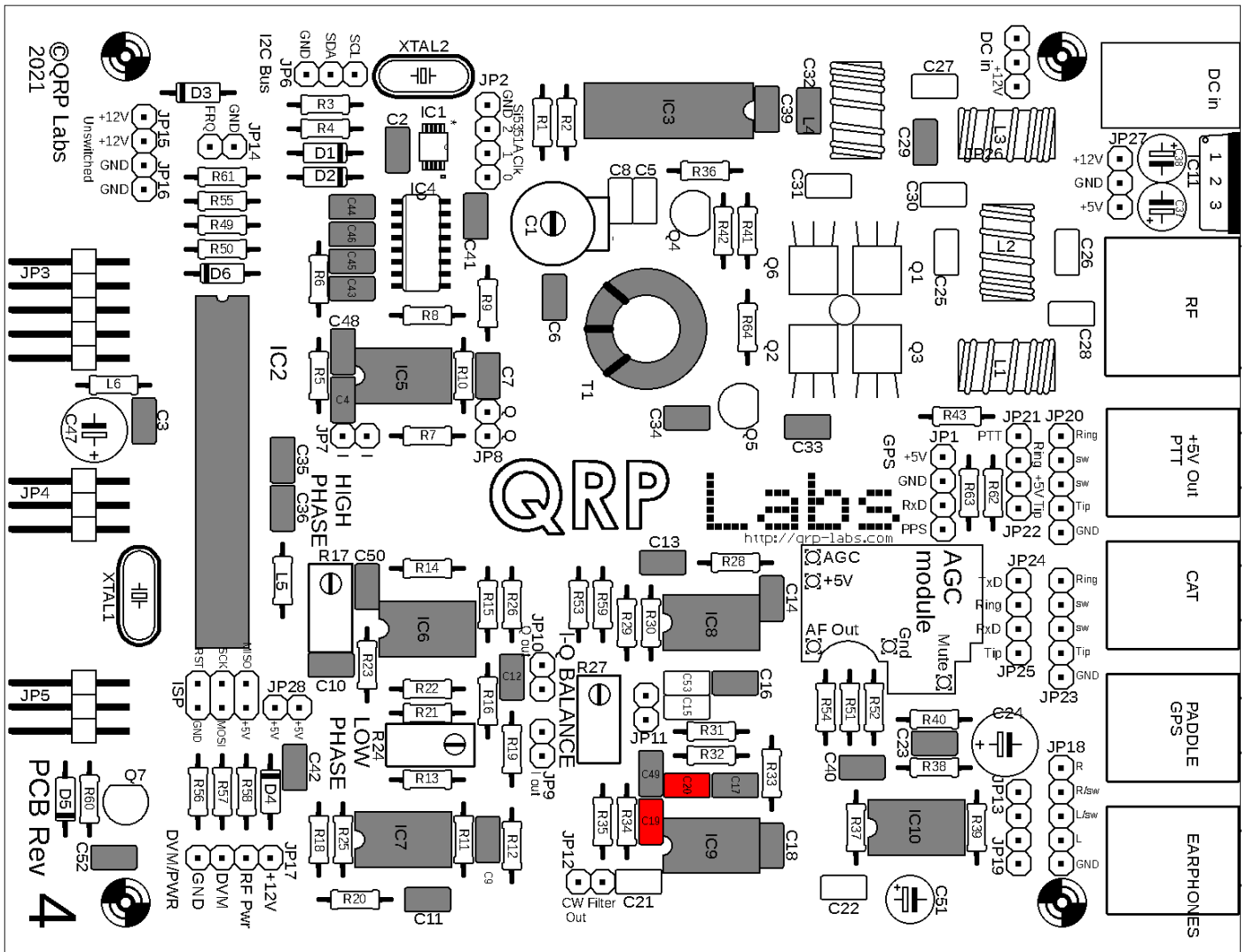

3.12 Install 33nF, “333” and 3.3nF, “332” capacitors

These are labelled “333” and “332”, and in parallel make up 36nF. They are C15 and C53.

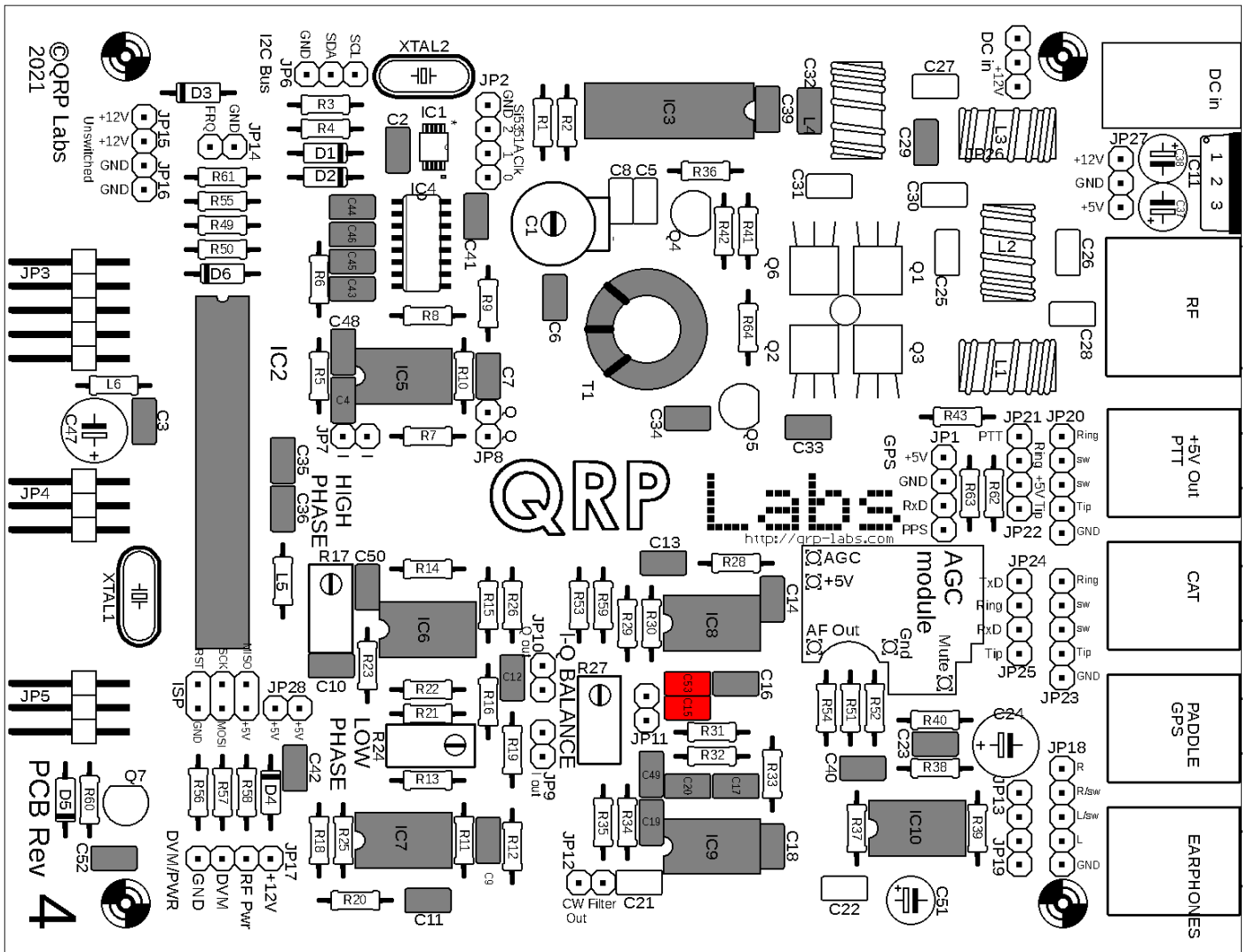

3.13 Install capacitors C25 and C26 from the Low Pass Filter kit

The value of these capacitors depends on your chosen band. The capacitors are located inside the separate Low Pass Filter bag in your main kit bag. Refer to the following table to find the correct capacitor value for your band:

Band	Value	Label
160m	2200pF	"222"
80m	1200pF	"122"
60m	1200pF	"122"
40m	680pF	"681"
30m	560pF	"561"
20m	390pF	"391"
17m	270pF	"271"

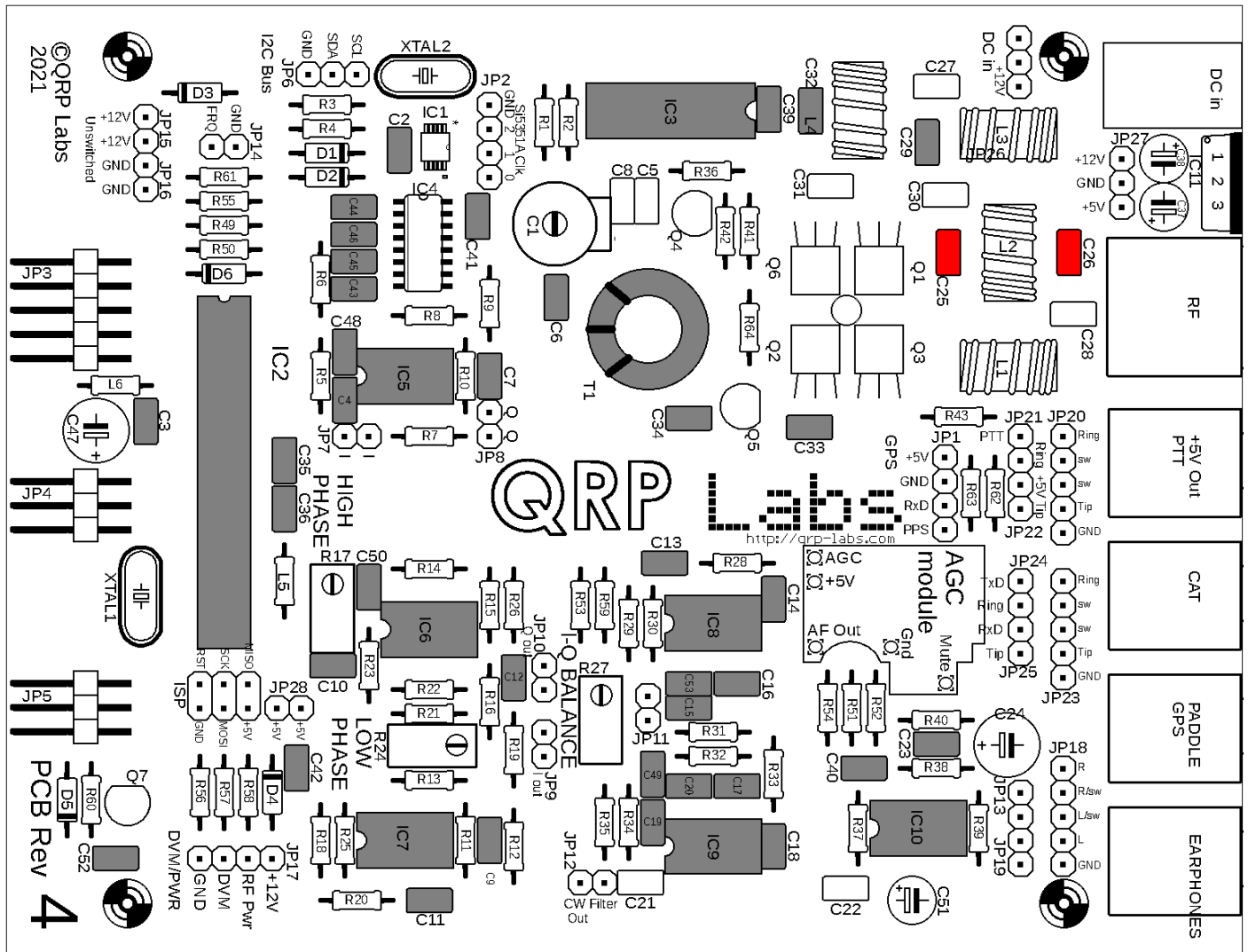

3.14 Install capacitors C27 and C28 from the Low Pass Filter kit

The value of these capacitors depends on your chosen band. The capacitors are located inside the separate Low Pass Filter bag in your main kit bag. Refer to the following table to find the correct capacitor value for your band:

Band	Value	Label
160m	820pF	"821"
80m	470pF	"471"
60m	680pF	"681"
40m	270pF	"271"
30m	270pF	"271"
20m	180pF	"181"
17m	100pF	"101"

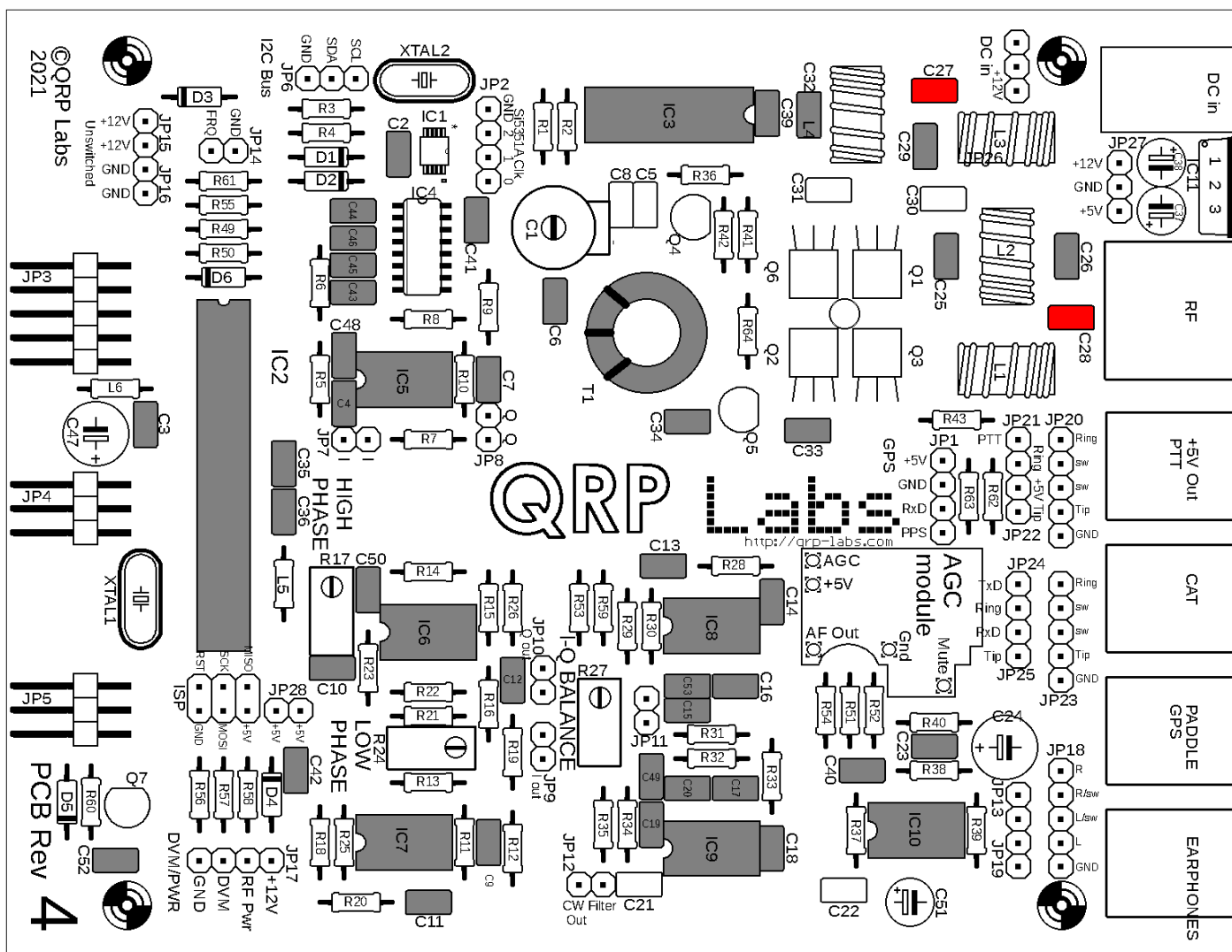

3.15 Install capacitor C30

This capacitor is band dependent. The kit contains all required capacitor values for all bands. Install the one appropriate to your band. Refer to the following table to find the correct capacitor value for your band:

Band	Value	Label
160m	820pF	"821"
80m	180pF	"181"
60m	30pF	"300"
	56pF	"560"
40m	56pF	"560"
30m	30pF	"300"
20m	30pF	"300"
17m	30pF	"300"

60m important note: for the 60m band, the capacitor requires both the 30pF and 56pF capacitors to be soldered in parallel, but there is only one component position on the PCB. For 60m, you will need to install one of the capacitors (e.g. 56pF) in the component holes provided, and solder the other one (e.g. 30pF) to the same pads under the PCB. Take care to keep the component wires short and not accidentally touching any other nearby components or soldered pads.

80m important note: the 180pF capacitor supplied has a 0.2-inch (5.08mm) pin spacing. But the holes on the PCB are spaced 0.1-inch (2.5mm). It is necessary to squeeze the capacitors wires carefully closer together to fit the PCB holes.

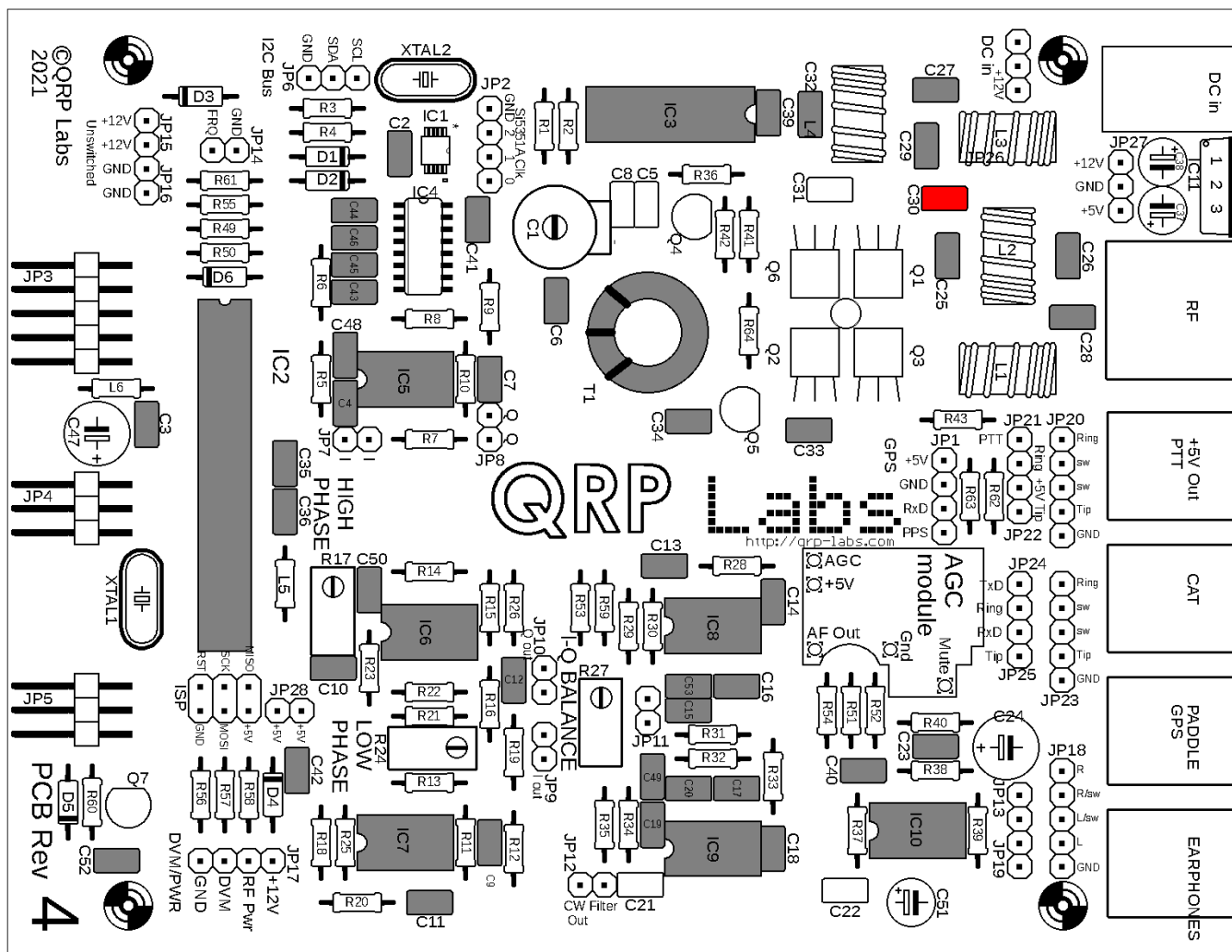

3.16 Install capacitors C5 and C8

These capacitors are band dependent. They add parallel capacitance to trimmer capacitor C1 to bring it to the required value. The kit contains all required capacitor values. Install the capacitor(s) appropriate to your band. Refer to the following table to find the correct capacitor value(s) for your band. Where “none” is indicated in the table, do not install the corresponding capacitor.

Band	C5 Value	C5 Label	C8 value	C8 Label
160m	100pF	“101”	22pF	“220”
80m	39pF	“390”	22pF	“220”
60m	39pF	“390”	22pF	“220”
40m	39pF	“390”	none	
30m	22pF	“220”	none	
20m	none		none	
17m	none		none	

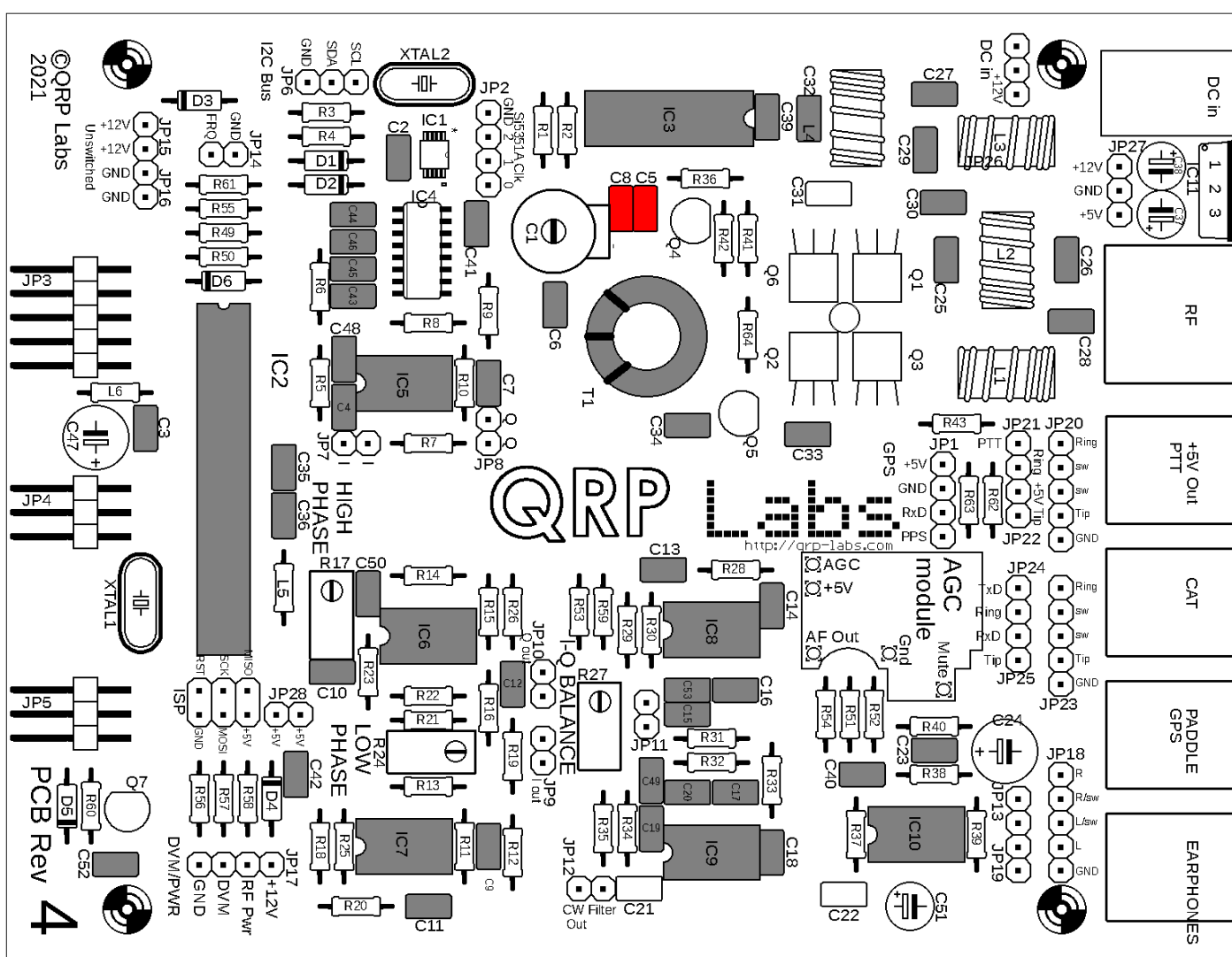

3.18 Install 2.2uF, "225" capacitor C31

The capacitor has 5.08mm pin spacing, but the holes are 2.54mm - you need to bend the wires carefully to fit in the holes.

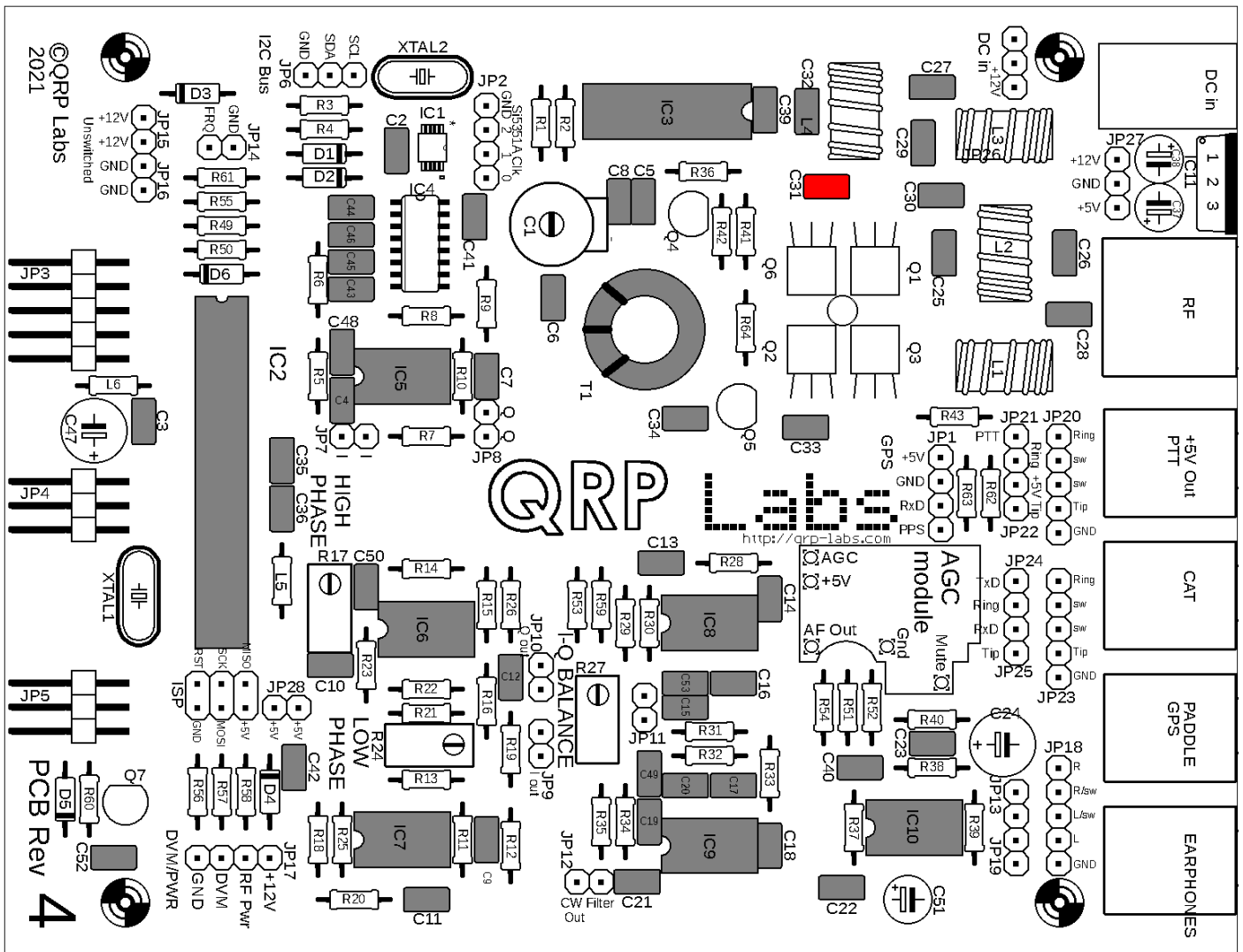

3.19 Install 1N4148 diodes

There are 5 small glass red-ish coloured diodes, D1, D2, D4, D5 and D6, which are all installed flat on the PCB.

In all cases it is critical to install the diodes the right way around, these are a polarised component and must only be installed in the PCB with the correct orientation! The PCB silkscreen printing shows a white stripe at the end of the diode body which must match the black stripe on the left end of the diode.

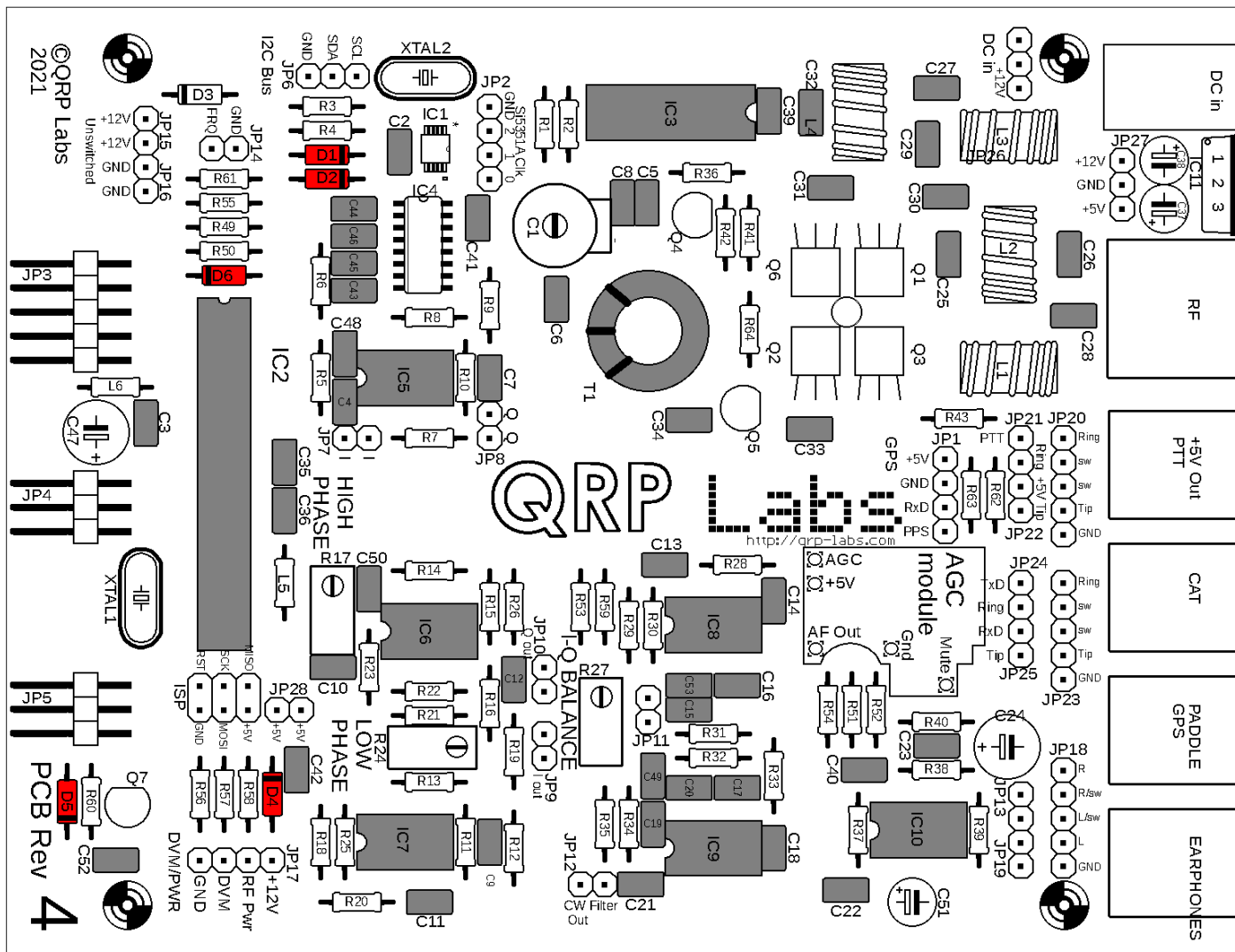

3.20 Install 1N5819 diode

This diode D3 is the larger diode with a black body, and a white stripe. It is installed horizontally. Again, it must be orientated correctly, with the white stripe on the diode matching the white stripe on the PCB.

This diode protects the radio against reverse polarity. So that if you connect the power to the board the wrong way around, you do not destroy it. A Schottky diode is used because the forward conducting voltage drop is less than an ordinary diode. However, on transmit, the voltage drop across this diode can still be up to 400mV. This reduction in voltage does slightly decrease the output power.

IF you want to squeeze every last milliwatt of output power out of the radio, and IF you trust yourself NEVER to connect the power supply in reverse by mistake, then if you just install a jumper wire instead of D3, it would give you a little higher RF power output.

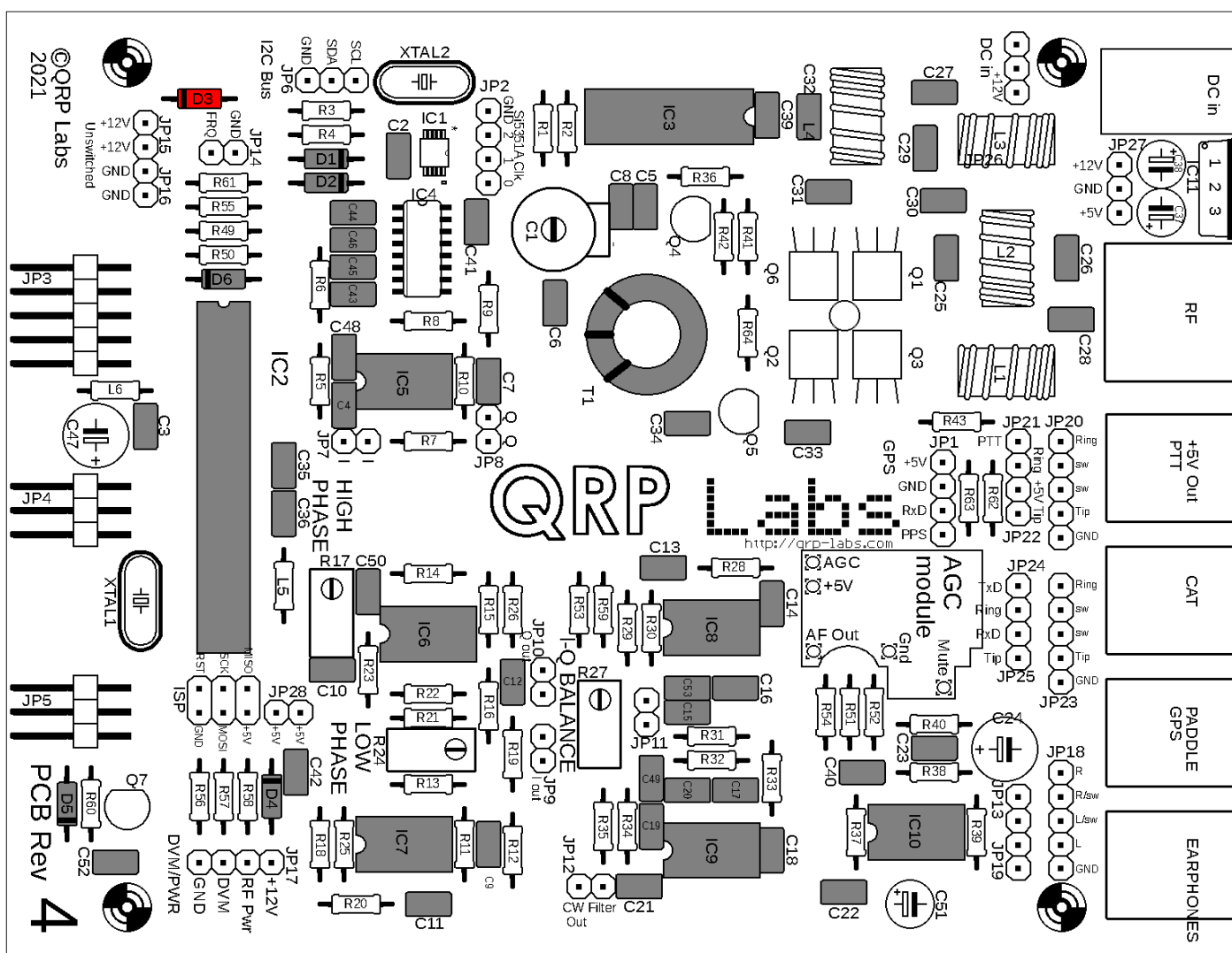

3.22 Install 27MHz crystal XTAL2

The engraving on this crystal is "27.000".

Note that if you are going to install the TCXO module option, DO NOT install 27MHz XTAL2. Skip this step!

If using the TCXO module, menu 8.5 must be manually changed to 25,000,000.

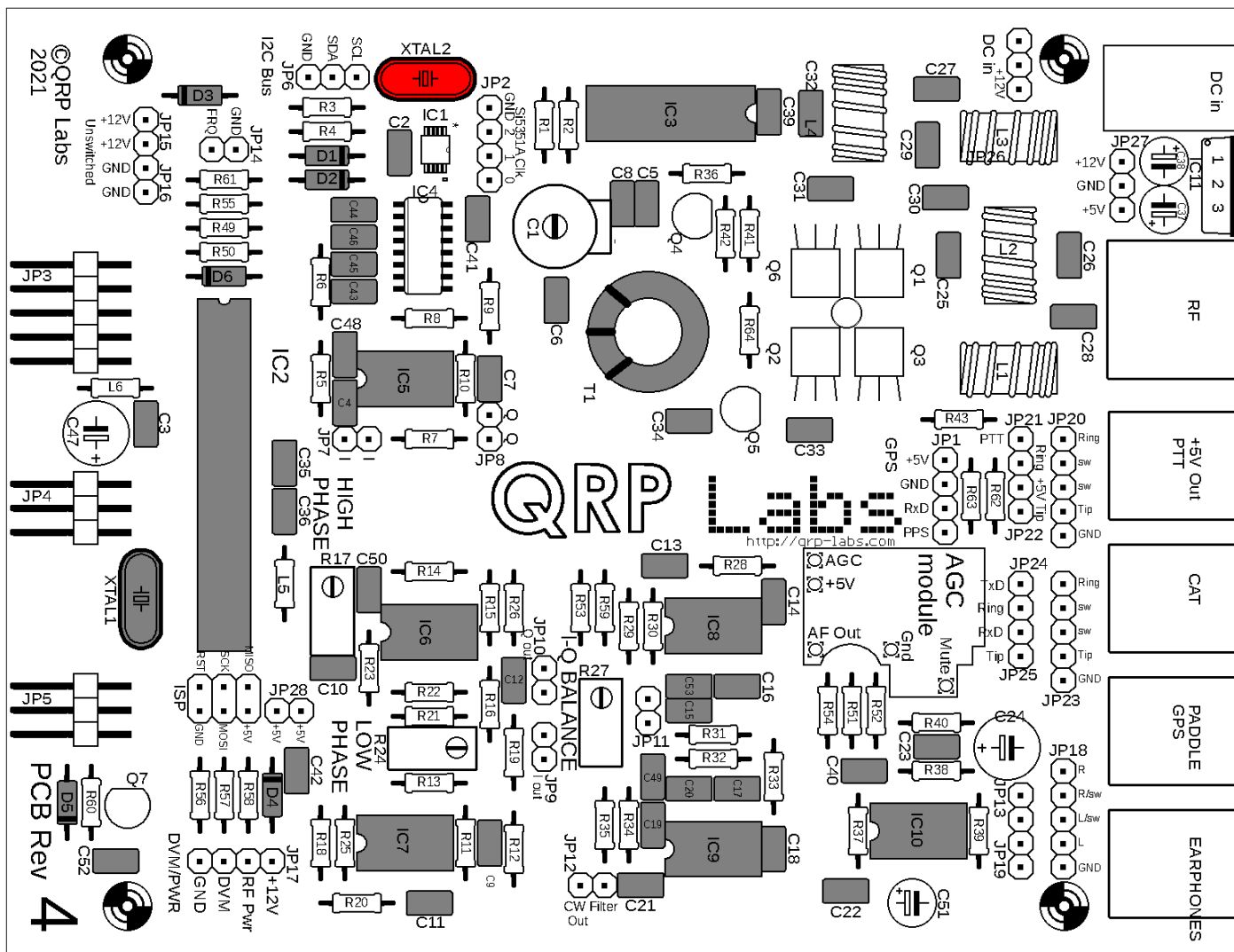

3.23 Install all main PCB 10K resistors

There are 15 10K resistors to be installed on the main board of the kit, these are R1, R2, R7, R10, R14, R21, R34, R36, R39, R40, R51, R52, R57, R58 and R64. The colour code is brown-black-black-red-brown. All of the resistors in the kit are installed flat horizontally on the board.

Resistors are not polarised components and it does not matter which way around they are installed.

There will be one 10K resistor left over at the end, this is to be installed on the front PCB in a later construction step (it is R46).

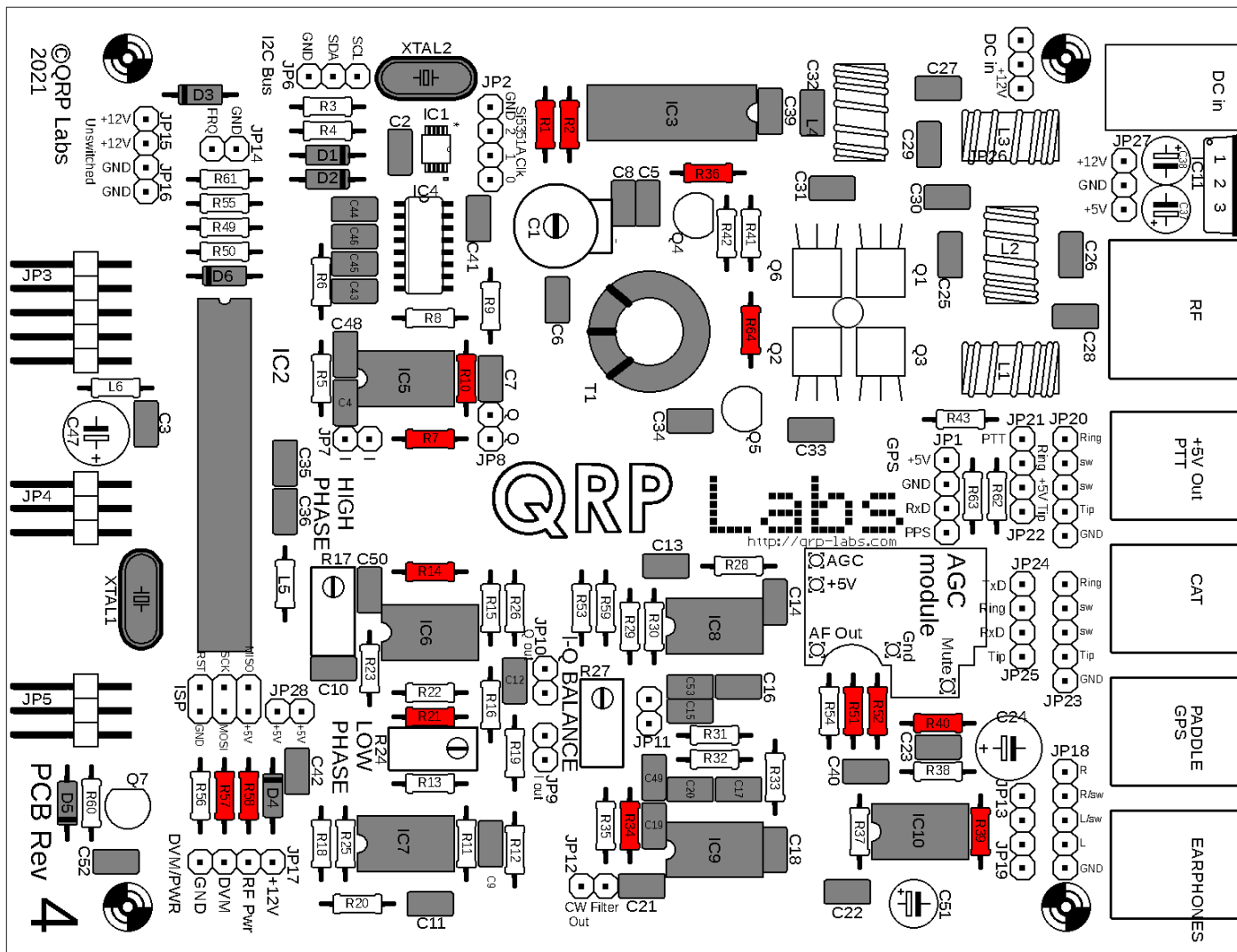

3.24 Install all main PCB 1K resistors

There are 10 1K resistors to be installed on the main board of the kit, these are R3, R4, R19, R26, R37, R49, R54, R55, R62 and R63. The colour code is brown-black-black-brown-brown.

There will be one 1K resistor left over at the end, this is to be installed on the front PCB in a later construction step (it is R45).

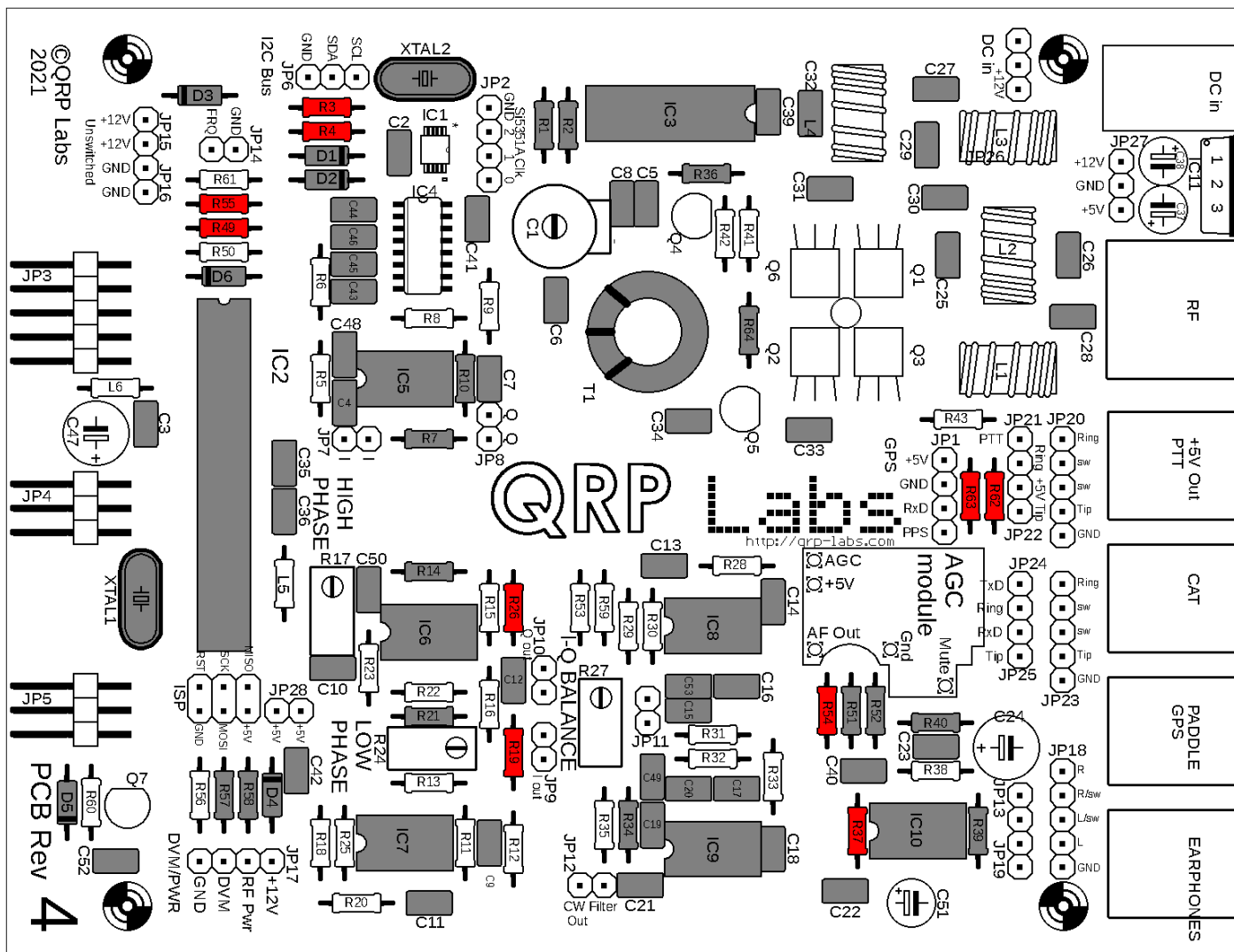

3.25 Install all main PCB 3.3K resistors

There are 11 3.3K resistors to be installed on the main board of the kit, these are R12, R13, R15, R16, R20, R22, R23, R25, R53, R56, and R59. The colour code is orange-orange-black-brown-brown.

There will be two 3.3K resistors left over at the end, these are to be installed on the front PCB in a later construction step (they are R44 and R65).

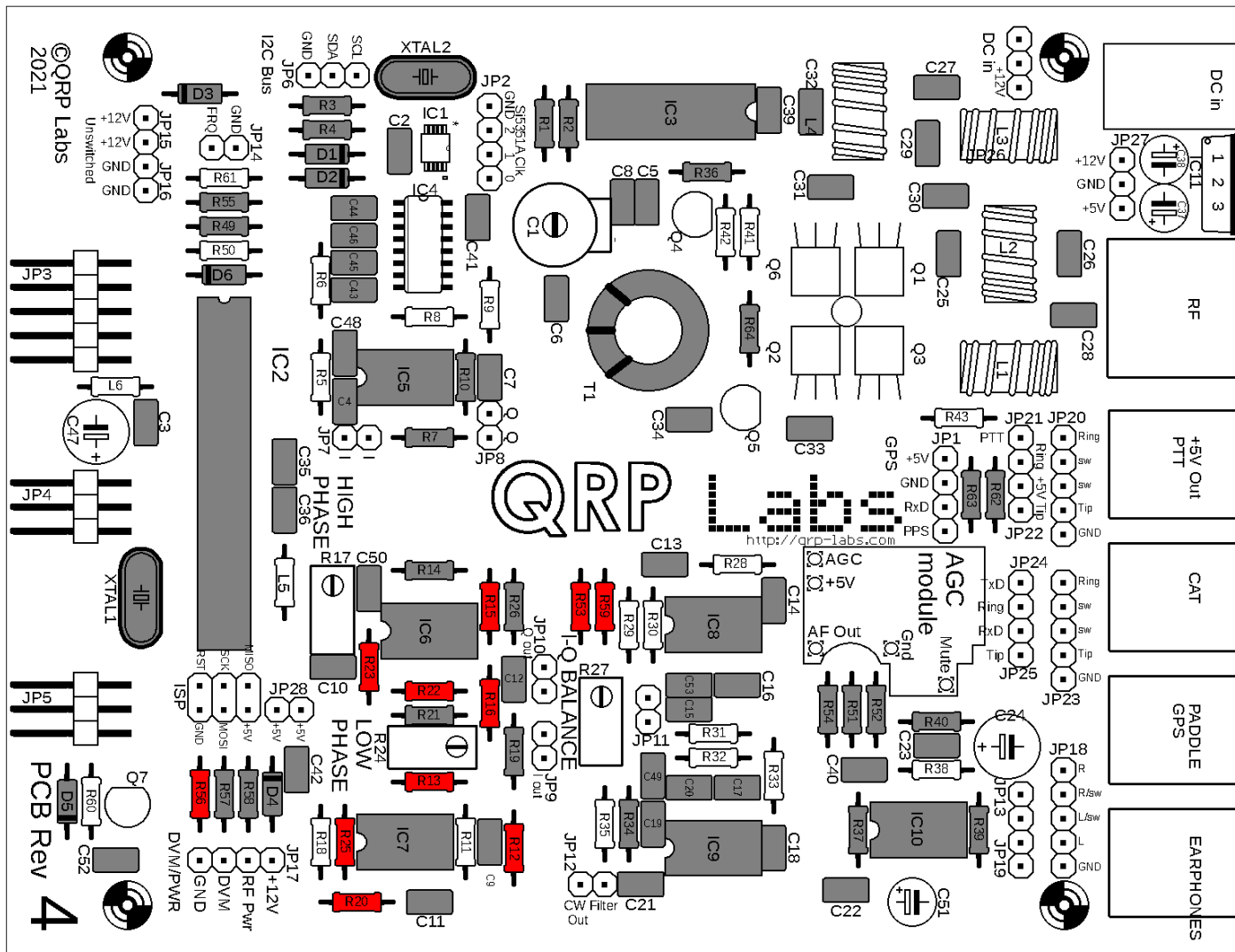

3.26 Install all 100-ohm resistors

There are four 100-ohm resistors in the kit, these are R5, R6, R8 and R9. The colour code is brown-black-black-black-brown.

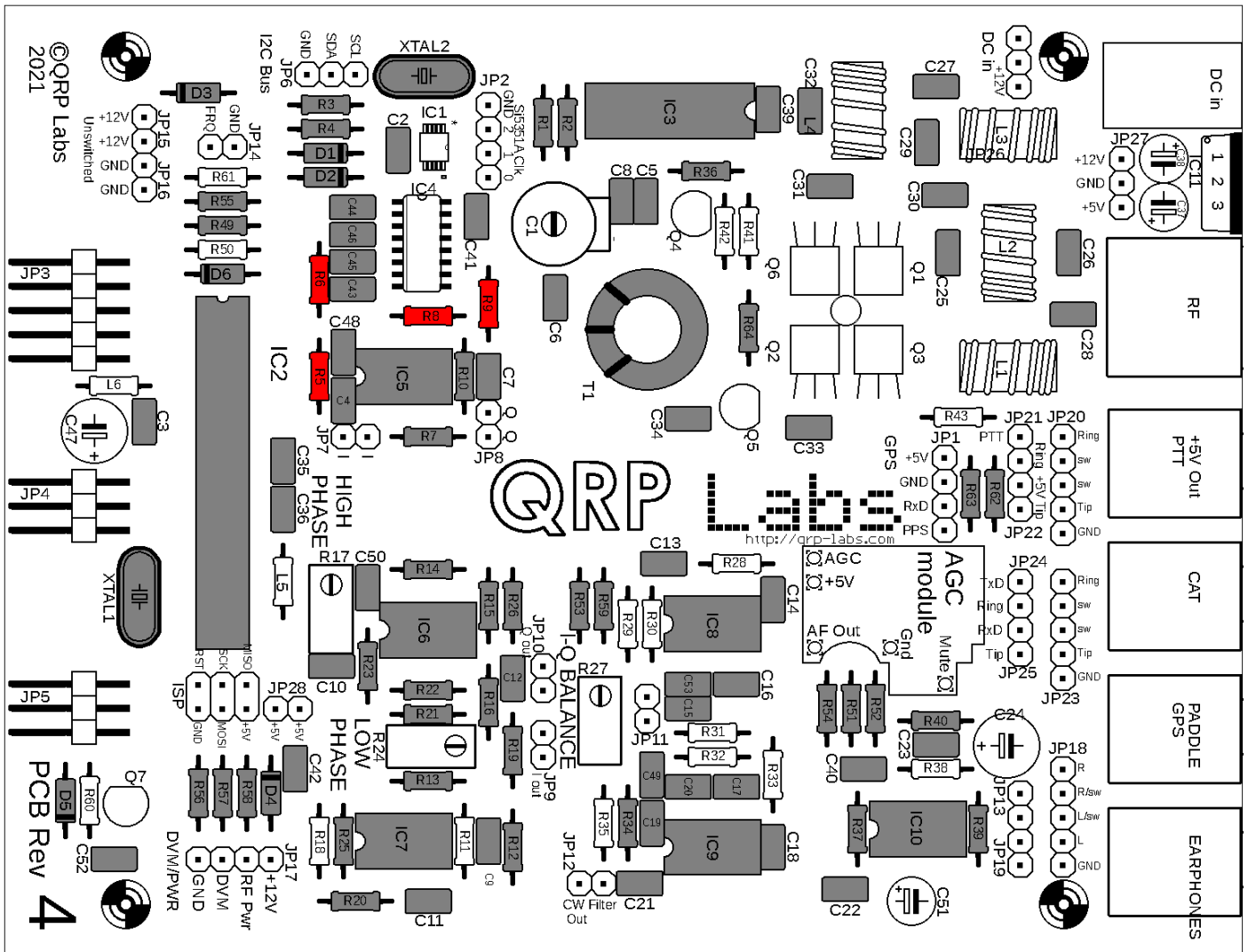

3.27 Install 120K resistors

There are three 120K resistors in the kit, these are R38, R43 and R60. The colour code is brown-red-black-orange-brown.

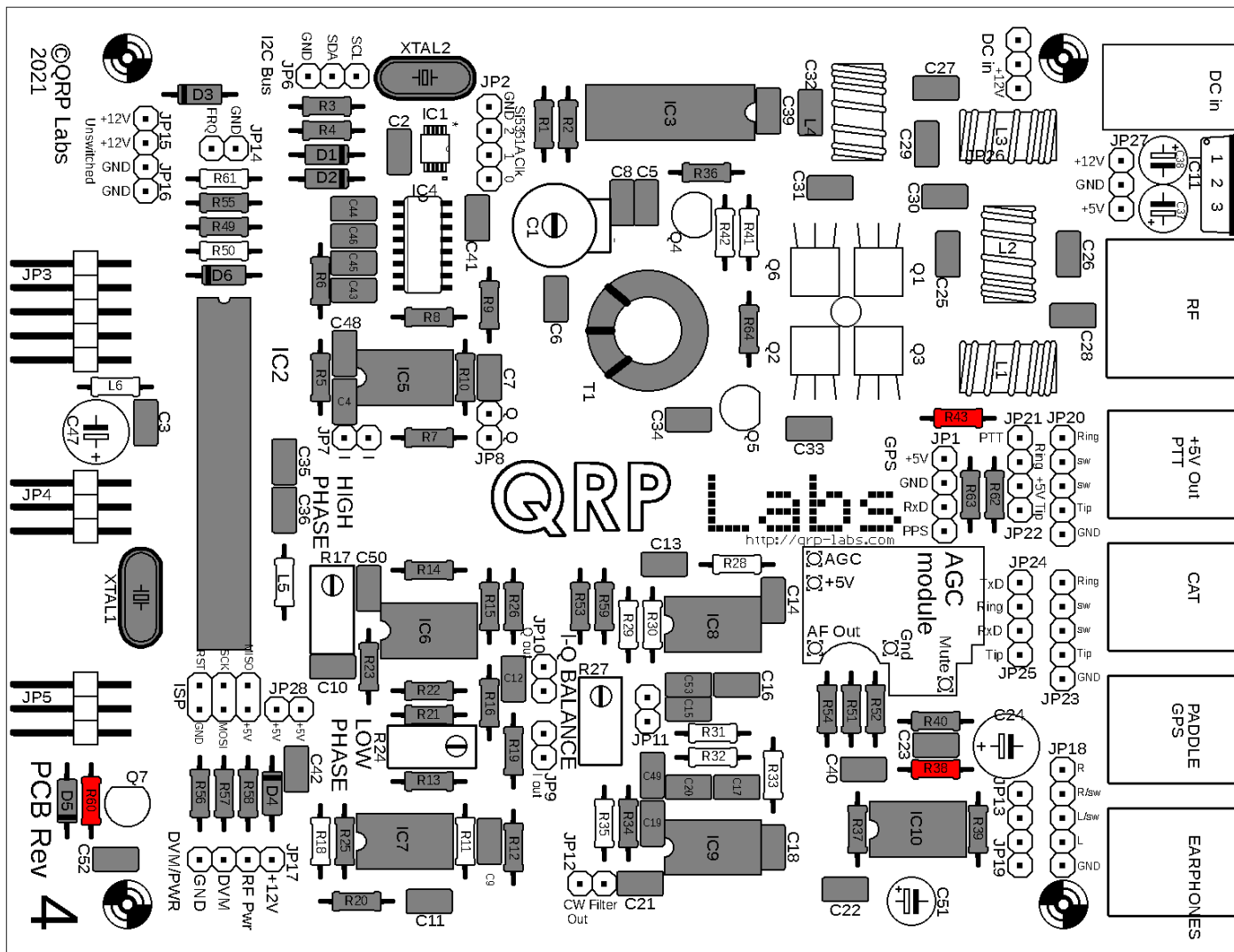

3.28 Install 33K resistors

There are two 33K resistors in the kit, these are R28 and R29. The colour code is orange-orange-black-red-brown.

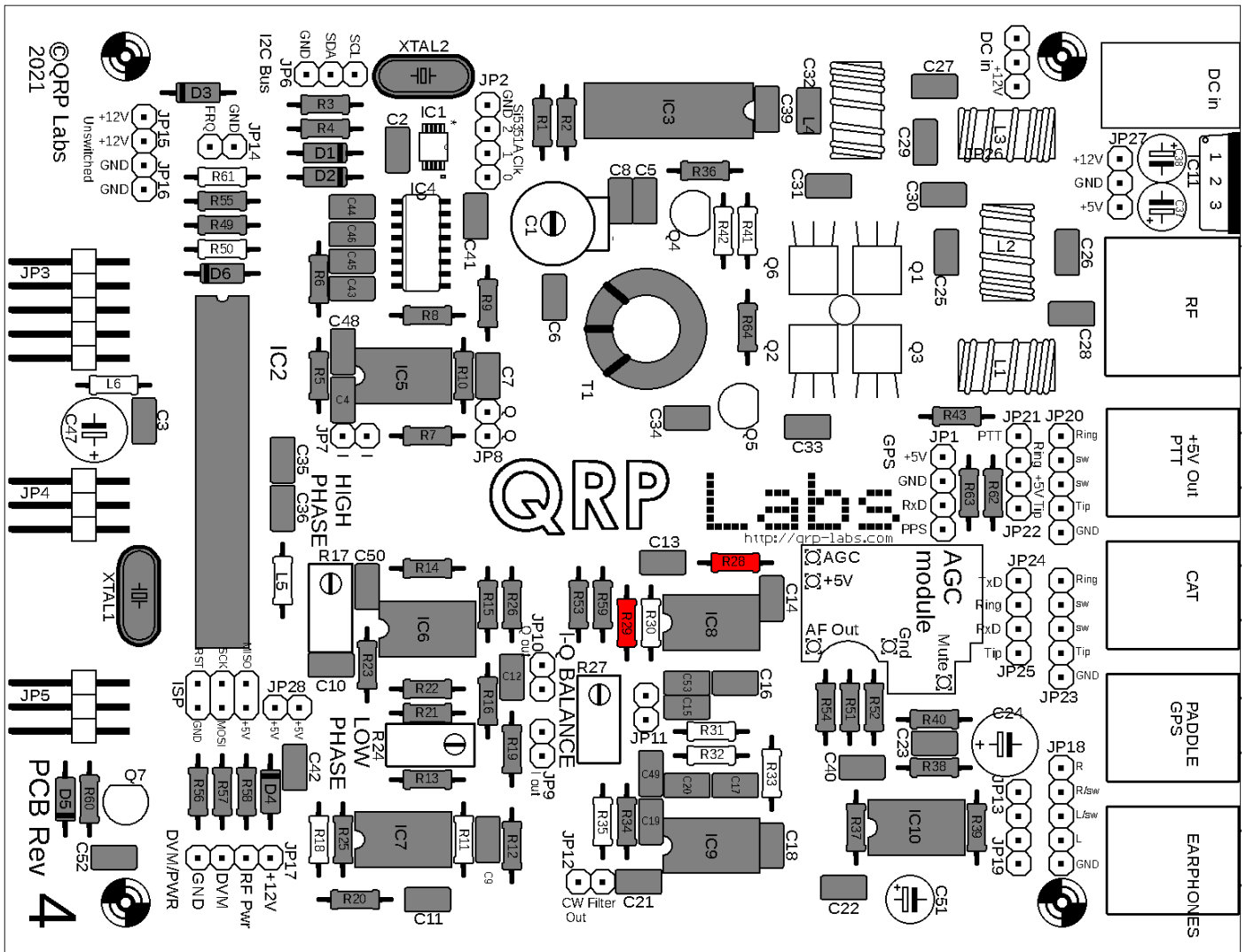

3.29 Install 47K resistors

There are two 47K resistors in the kit, these are R30 and R31. The colour code is yellow-purple-black-red-brown.

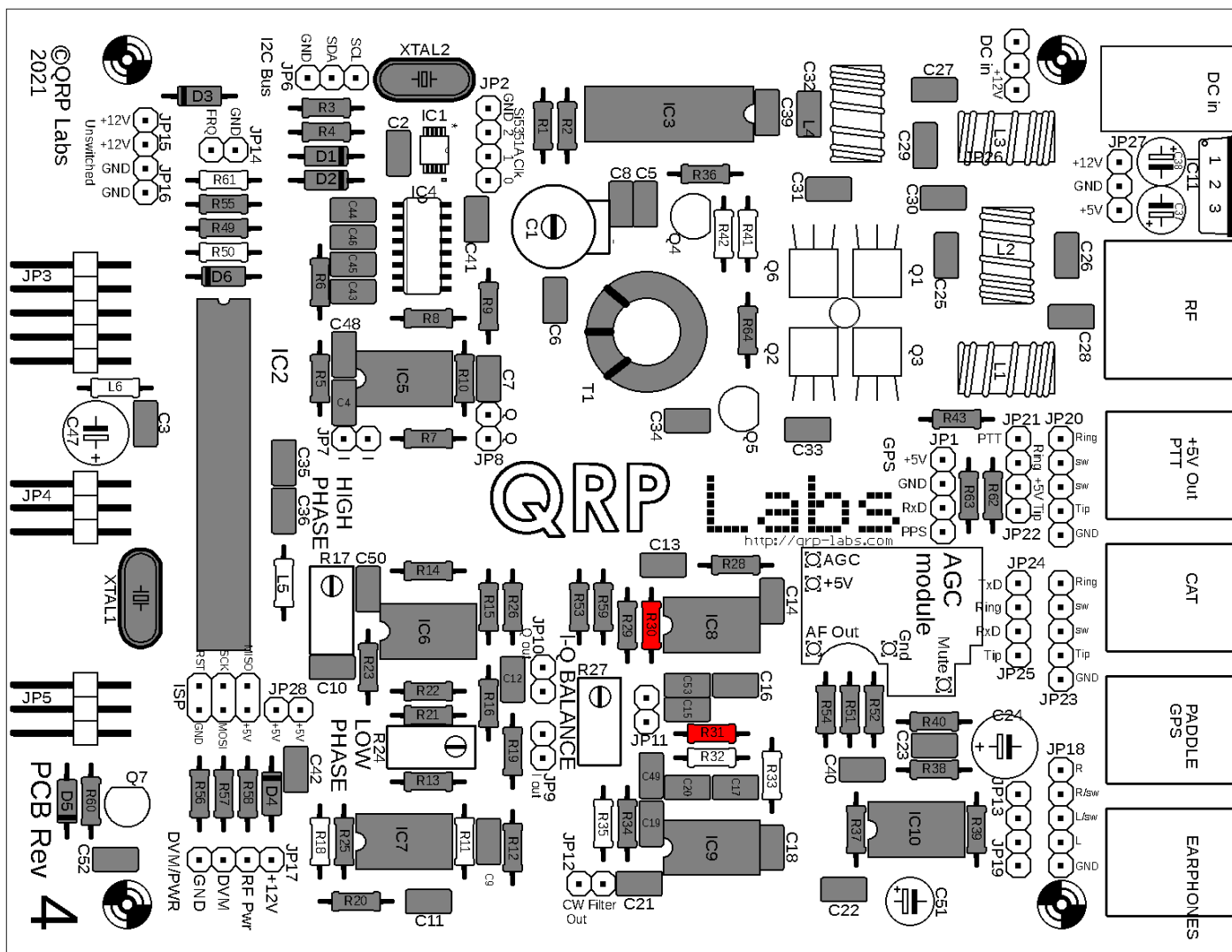

3.30 Install 36K resistors

There are two 36K resistors in the kit, these are R32 and R33. The colour code is orange-blue-black-red-brown.

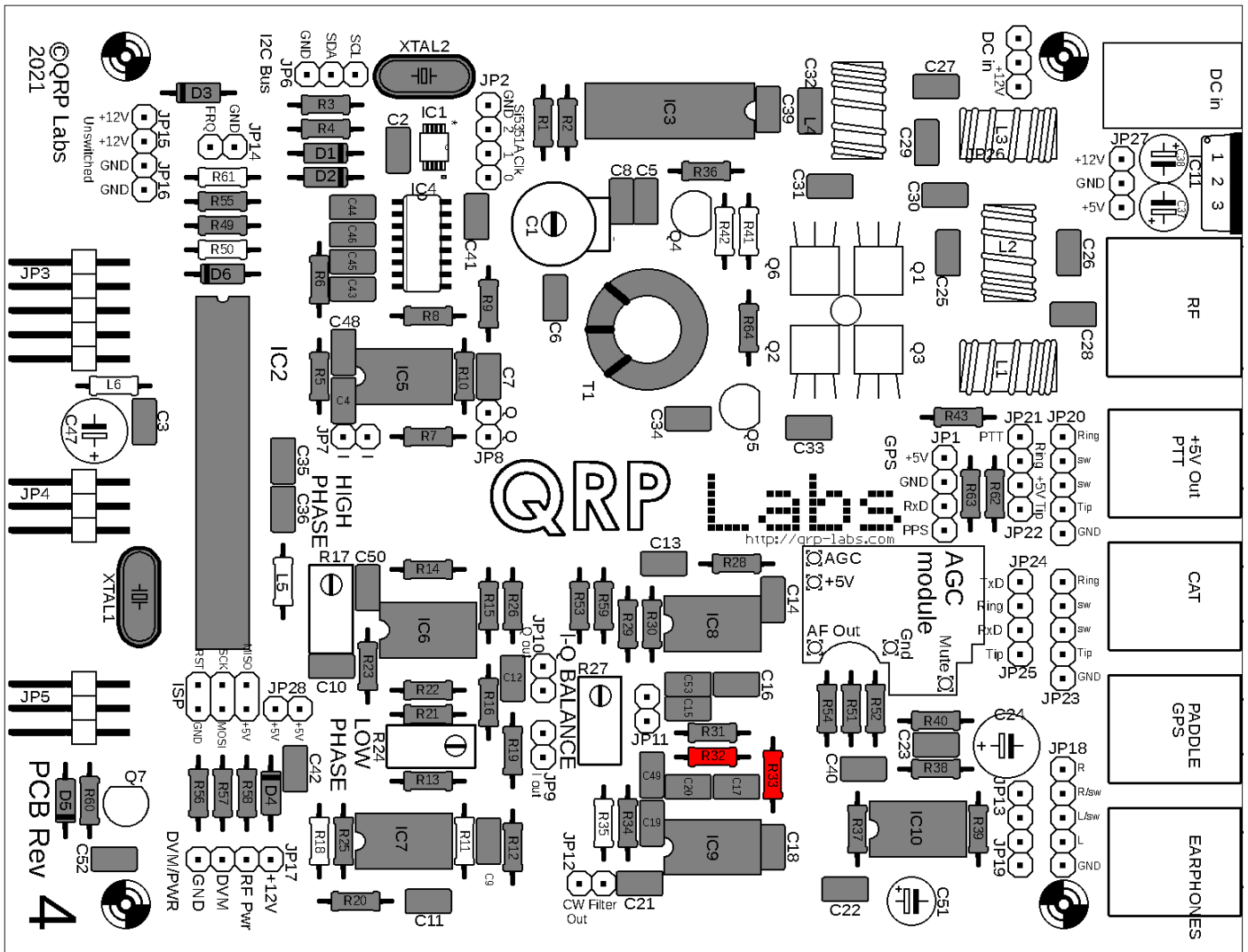

3.31 Install the main PCB 270-ohm resistor

There is one 270-ohm resistor to be installed on the main board of the kit, this is R50. The colour code is red-purple-black-black-brown. Note that this resistor is larger than the other resistors. This is because higher heat dissipation is required for R48 which is also 270-ohms and is used on the front PCB. You will need to bend the leads inwards a little under the resistor body, to fit in the holes.

There will be one 270-ohm resistor left over at the end, this is to be installed on the front PCB in a later construction step (it is R48).

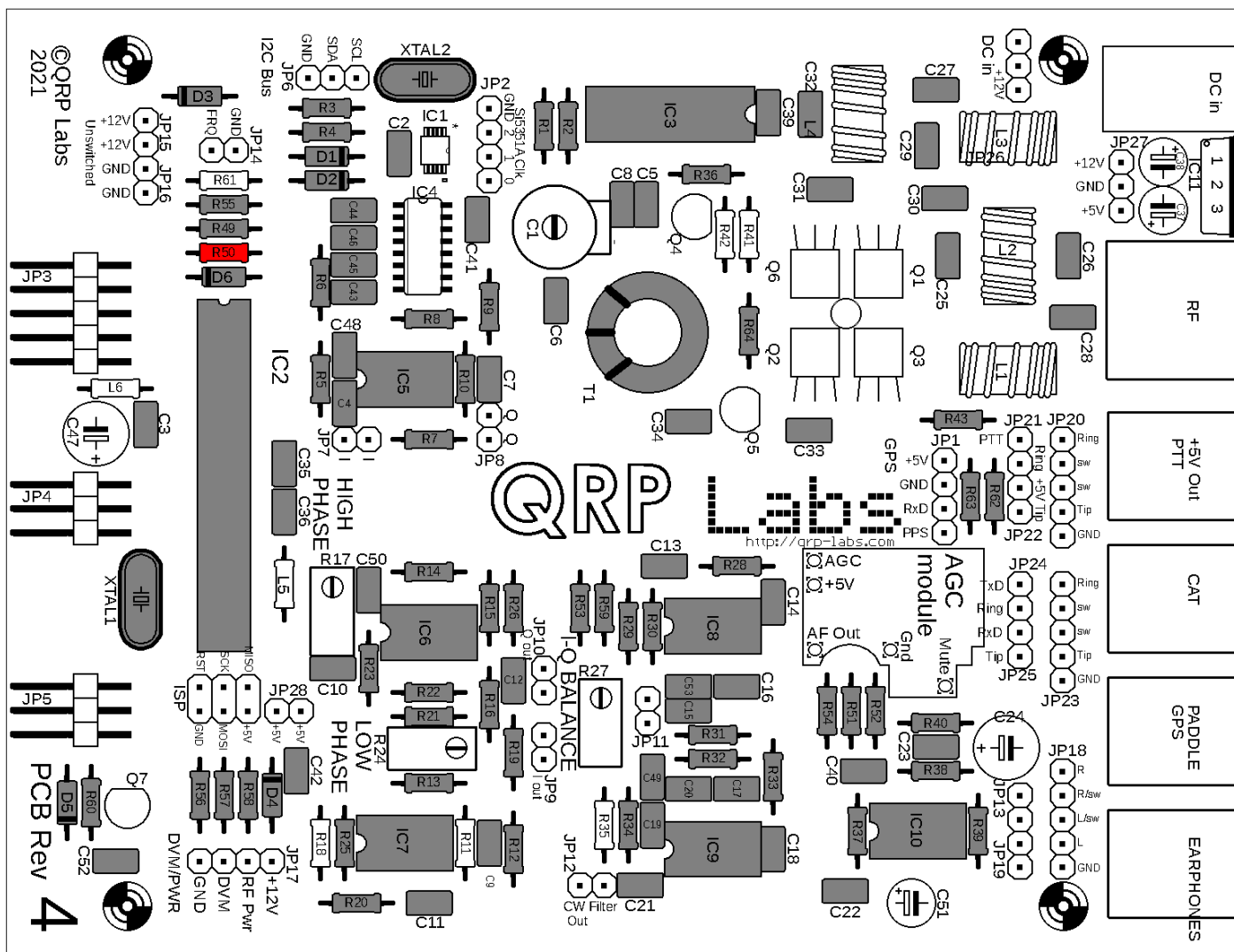

3.32 Install 1.2K or 820-ohm resistor R42

A 1.2K resistor has colour code brown-red-black-brown.

An 820-ohm resistor has colour code grey-red-black-black-brown.

Kits produced from July 2022 onward are supplied with an 820-ohm resistor. Before this date, the resistor was 1.2K. The change was necessary due to slightly different characteristics of the new batch of Q6 transistor (MPS751).

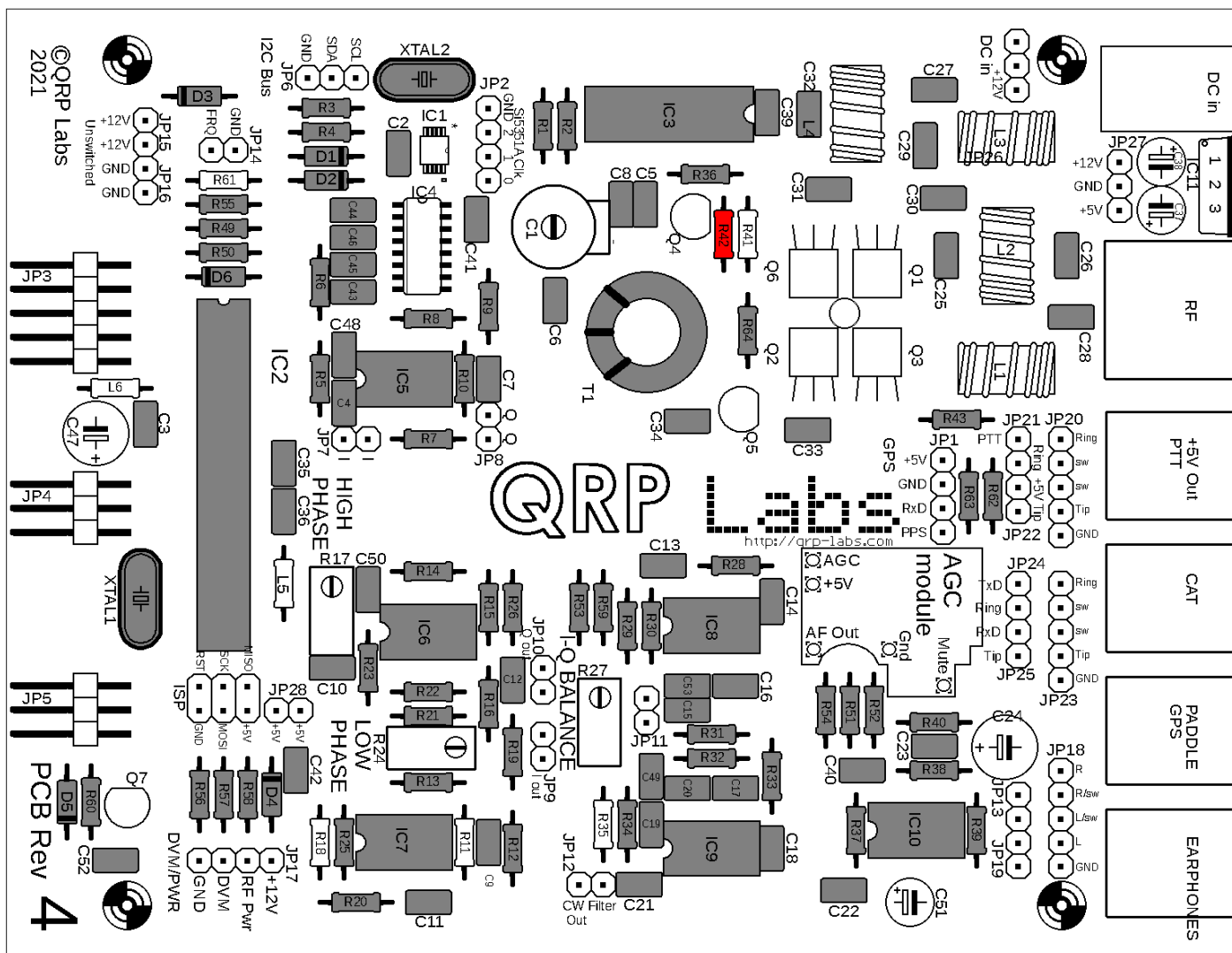

3.33 Install 150-ohm resistor R41

This resistor has colour code brown-green-black-black-brown.

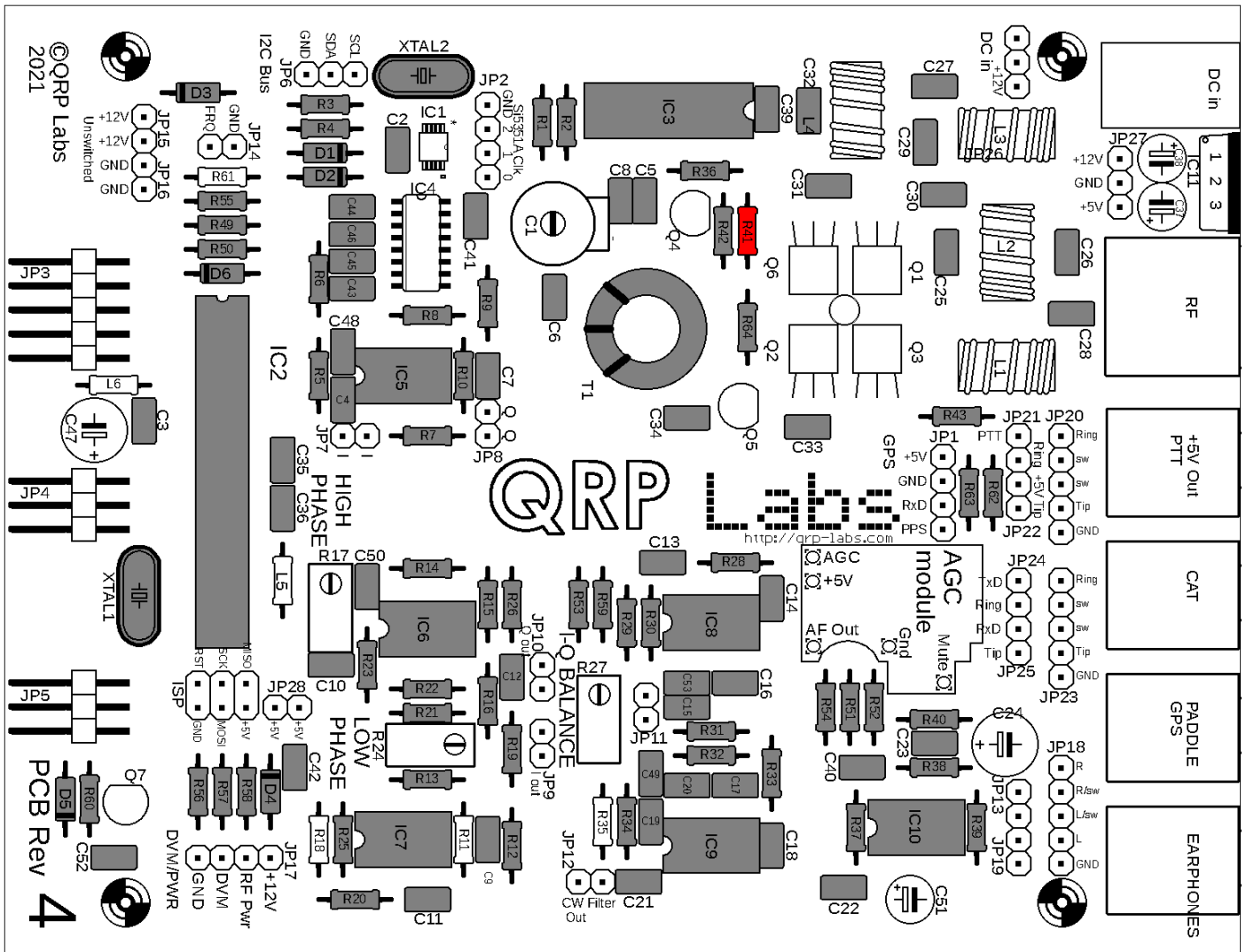

3.34 Install 3.9K resistor R61

This resistor has colour code orange-white-black-brown-brown.

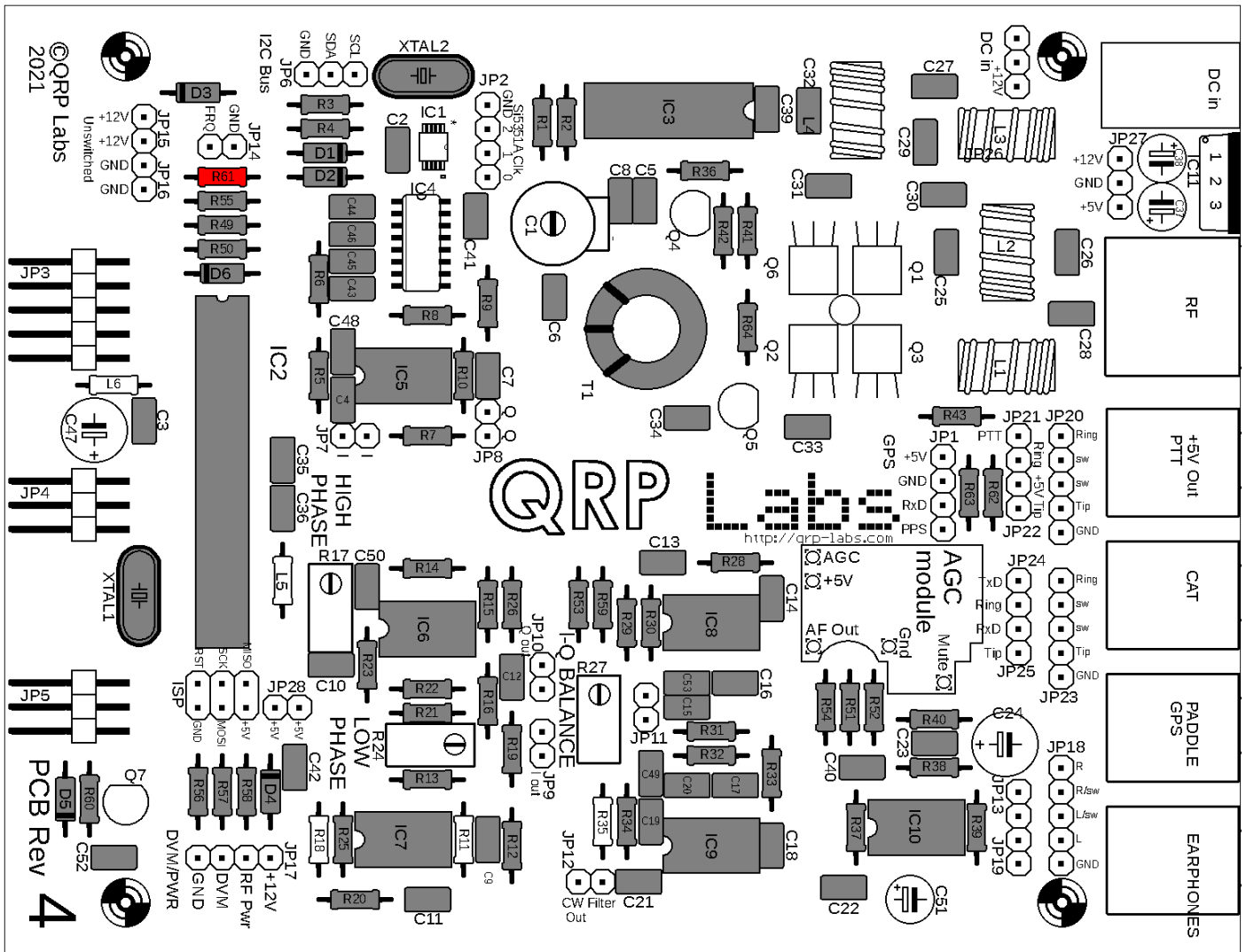

3.35 Install 4.3K resistor R18

This resistor has colour code yellow-orange-black-brown-brown.

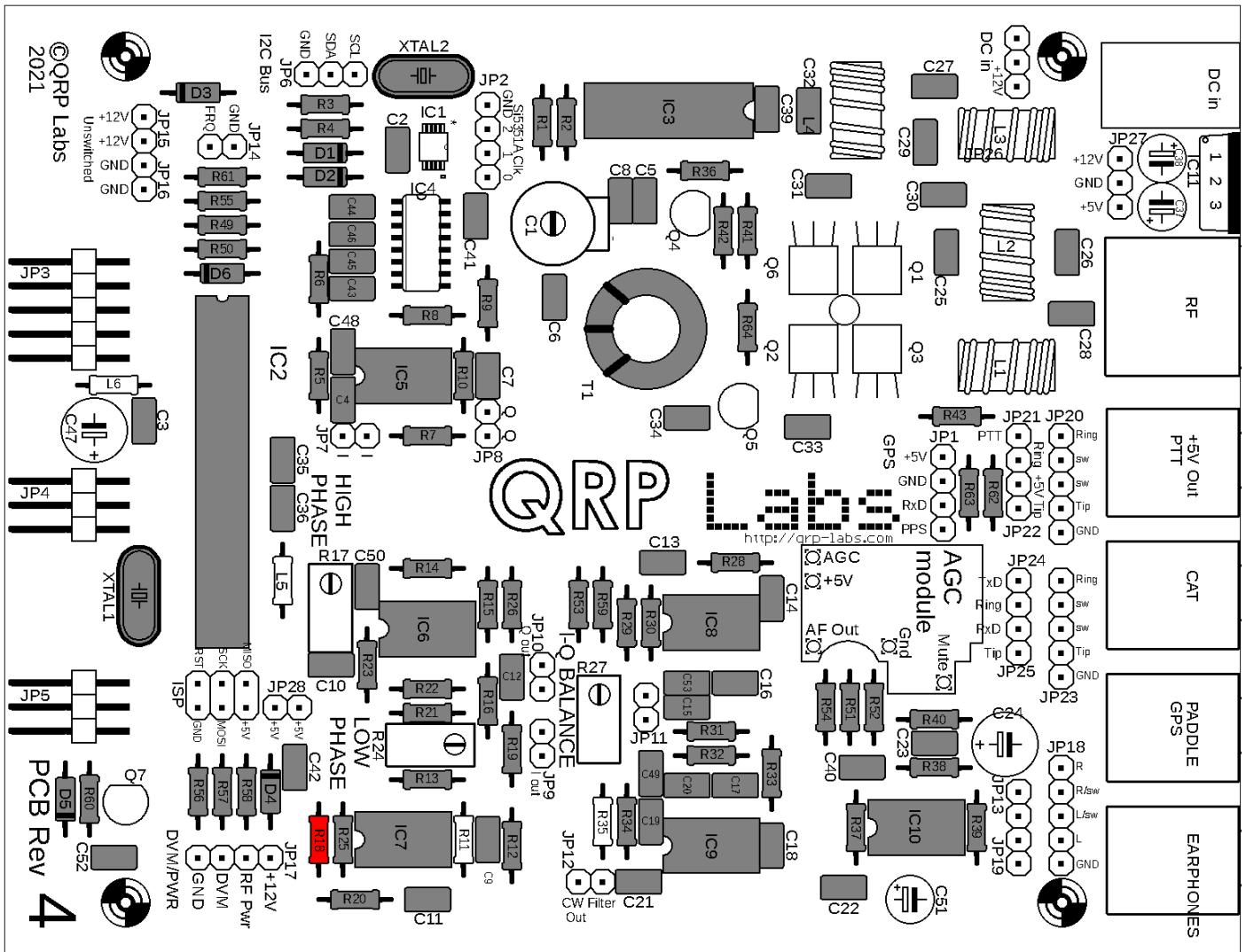

3.38 Install 500-ohm multi-turn trimmer potentiometer

This resistor is the small blue box component with label “501”. It is R27. The screw on the resistor should match the screw on the PCB silkscreen and layout diagram. But it is not a big problem if it does not; everything will still work fine. So if you accidentally install it the wrong way around, please don't risk damage by trying to remove it.

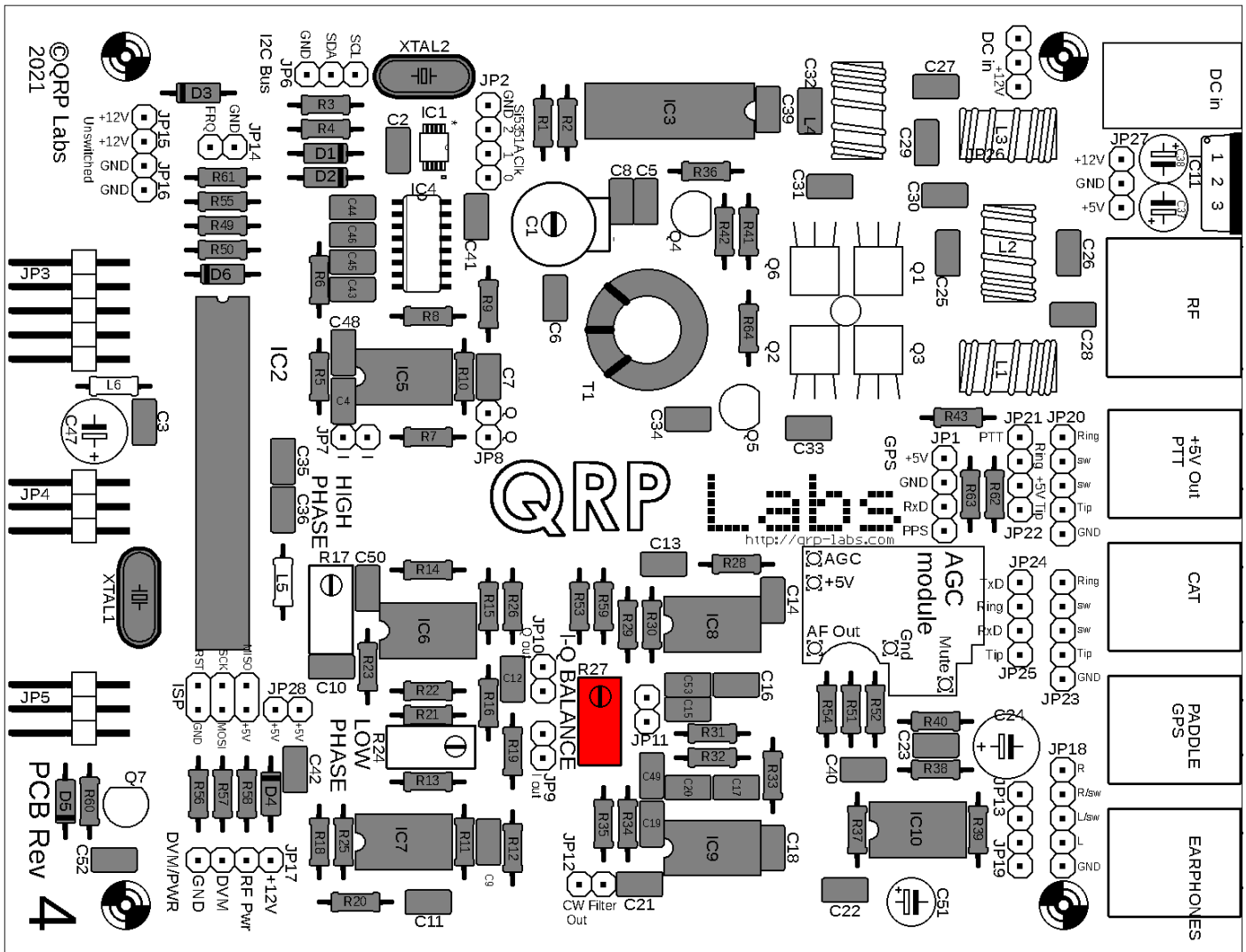

3.39 Install 50K multi-turn trimmer potentiometers

There are two 50K multi-turn trimmer potentiometers, R17 and R24. They are the small blue box components with label "503". The screws on the resistors should match the screws on the PCB silkscreen and layout diagram. But it is not a big problem if they does not; everything will still work fine. So if you accidentally install one the wrong way around, please don't risk damage by trying to remove it.

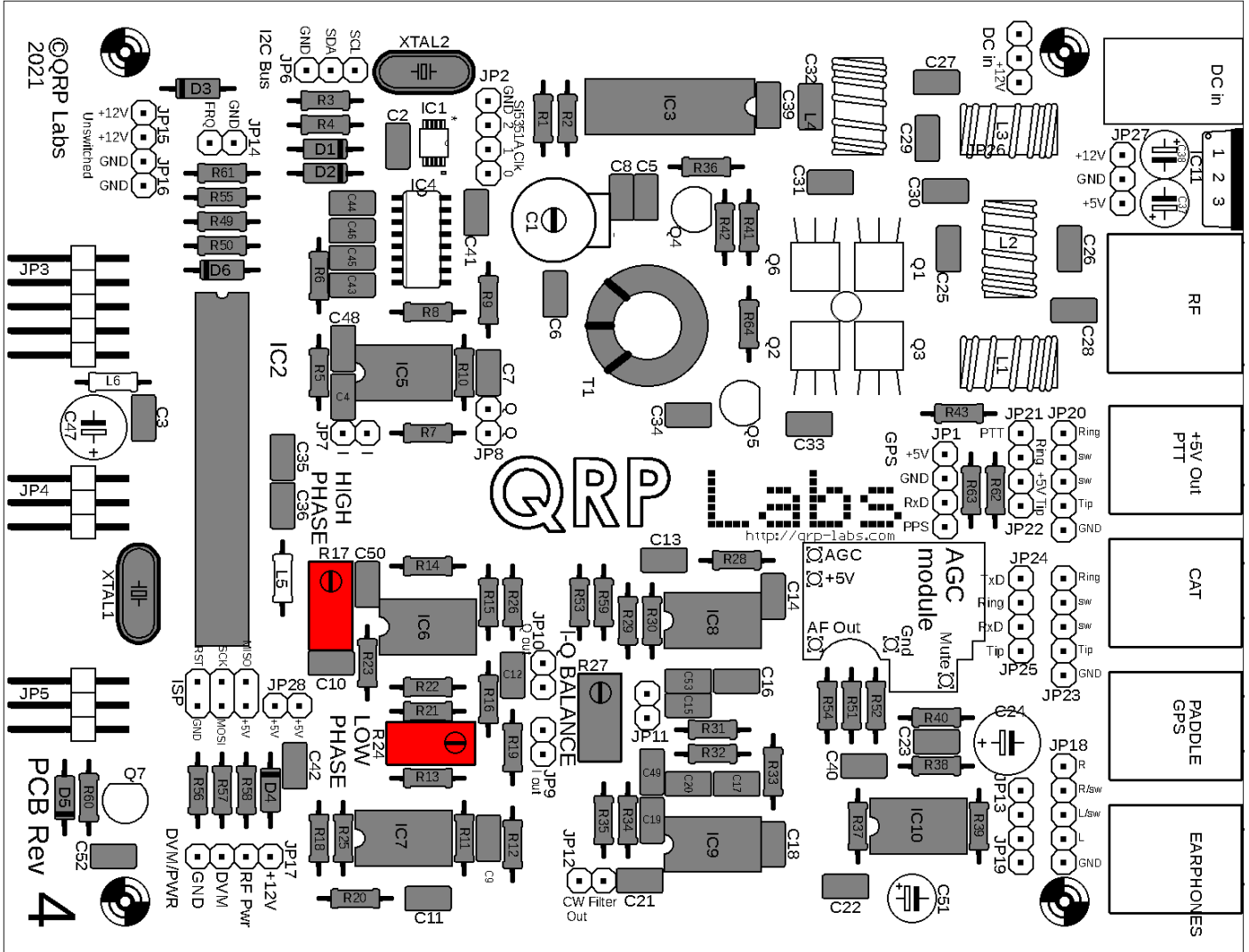

3.40 Install two 47uH inductors

There are two 47uH inductors, L5 and L6. These look like short fat resistors. They are installed horizontally on the PCB.

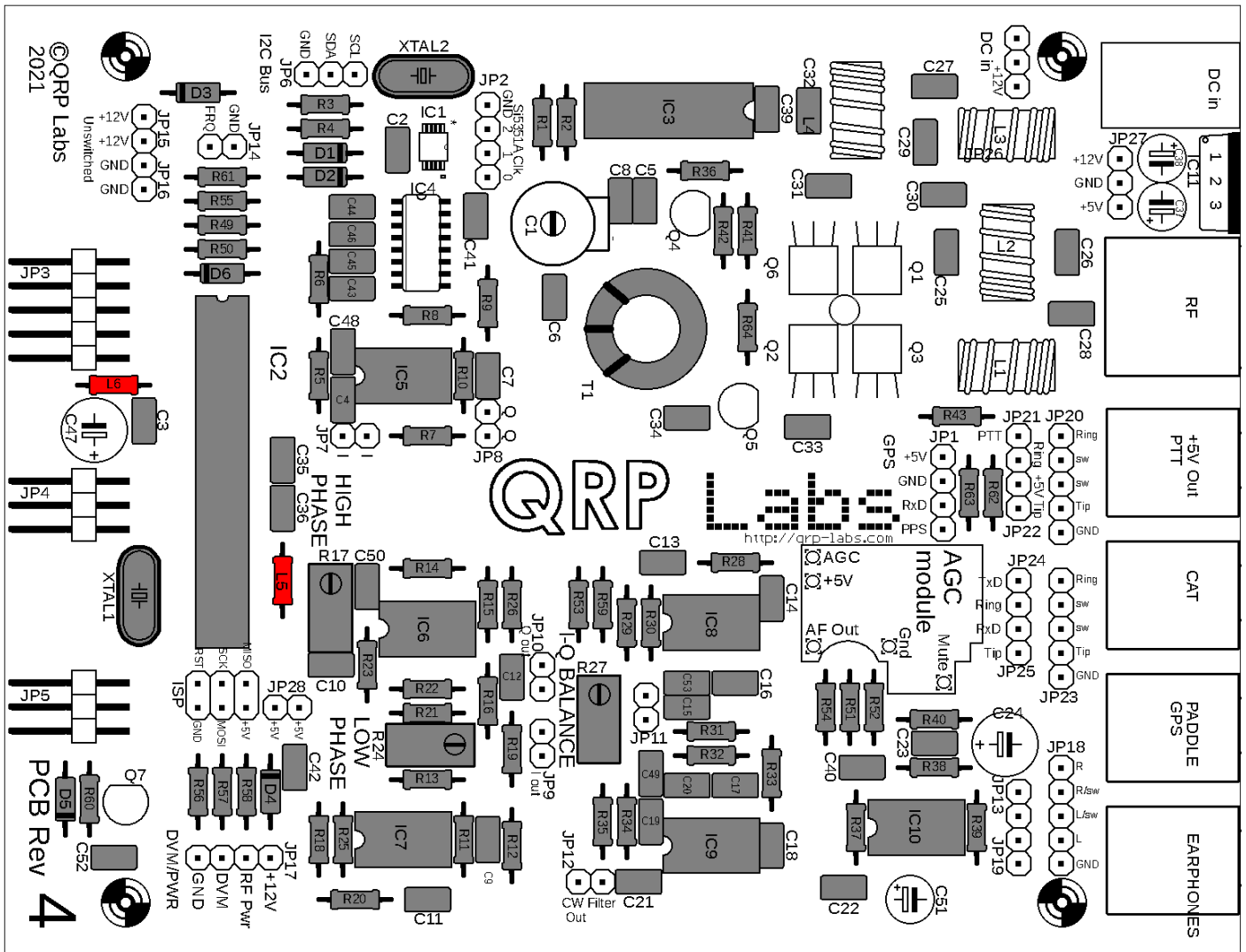

3.41 Install 10uF capacitors

There are three 10uF capacitors in the kit: C37, C38 and C51. These are polarised electrolytic capacitors and MUST be installed with the correct orientation! The capacitor NEGATIVE wire must be installed in the hole indicated on the PCB silkscreen and the layout diagram by the solid black bar; the POSITIVE wire must be installed in the hole indicated on the PCB silkscreen and the layout diagram by the hollow bar and the + symbol.

Electrolytic capacitors are also supplied with one wire longer than the other. The + wire is the longer wire, the - wire is the shorter one (see photo, right).

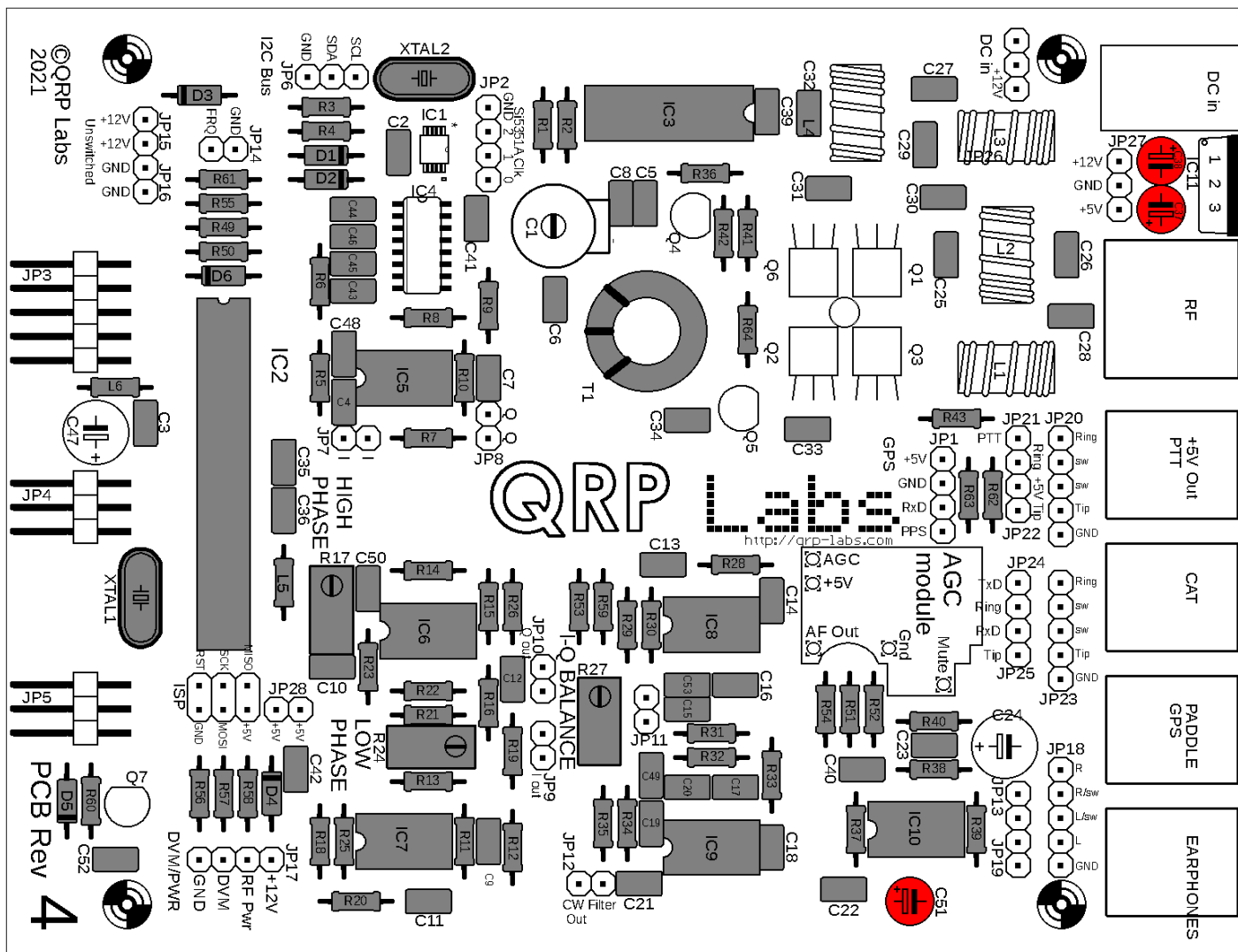

3.42 Install 470uF capacitors

These two capacitors are also polarised electrolytics and must be orientated correctly (see former section).

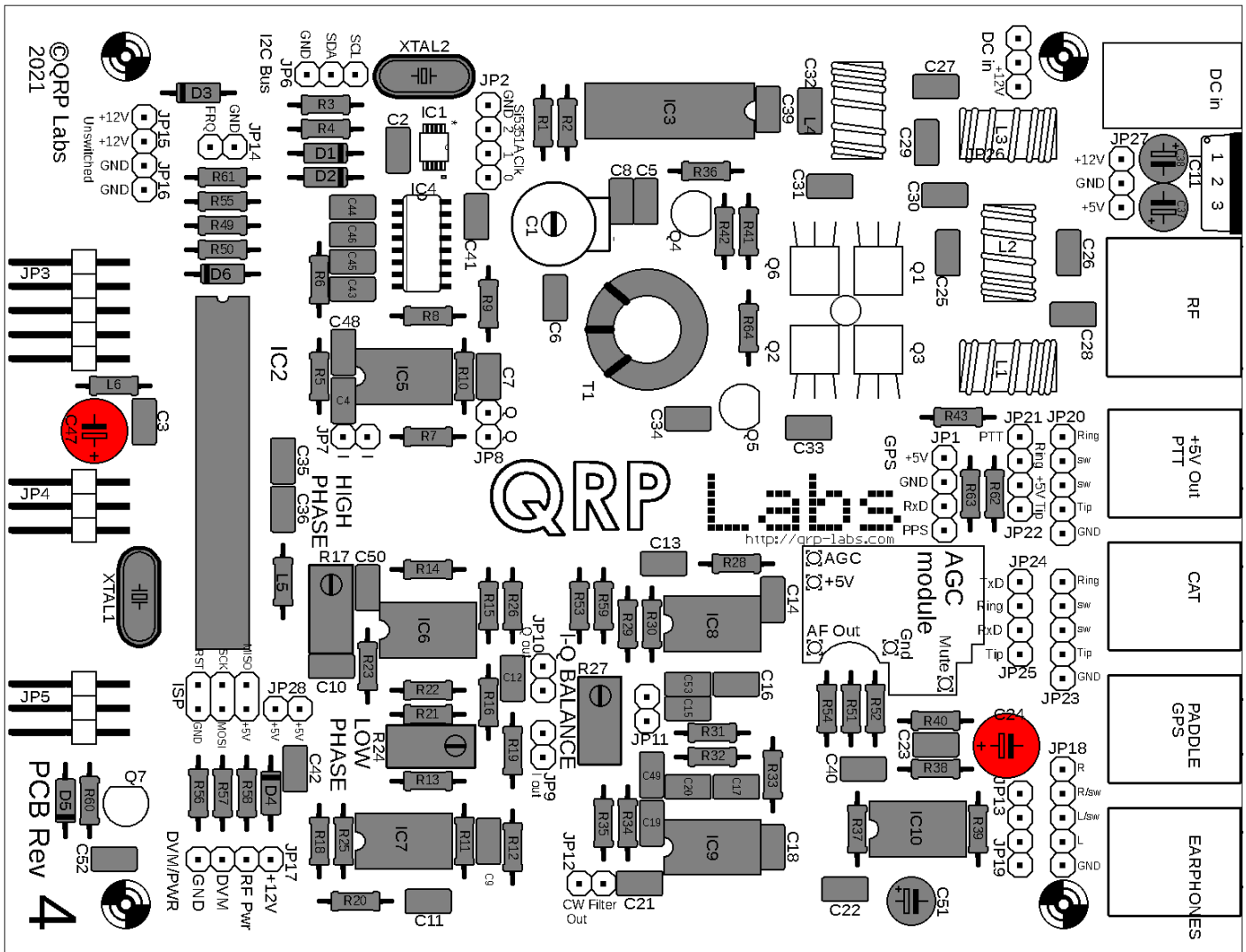

3.43 Install 30pF trimmer capacitor C1

Insert the component pins carefully and with the correct orientation which matches the PCB.

Cut the small pin stubs on the underside (solder side) of the PCB, they only protude a few mm but when installed in the enclosure could be rather close to the aluminium floor.

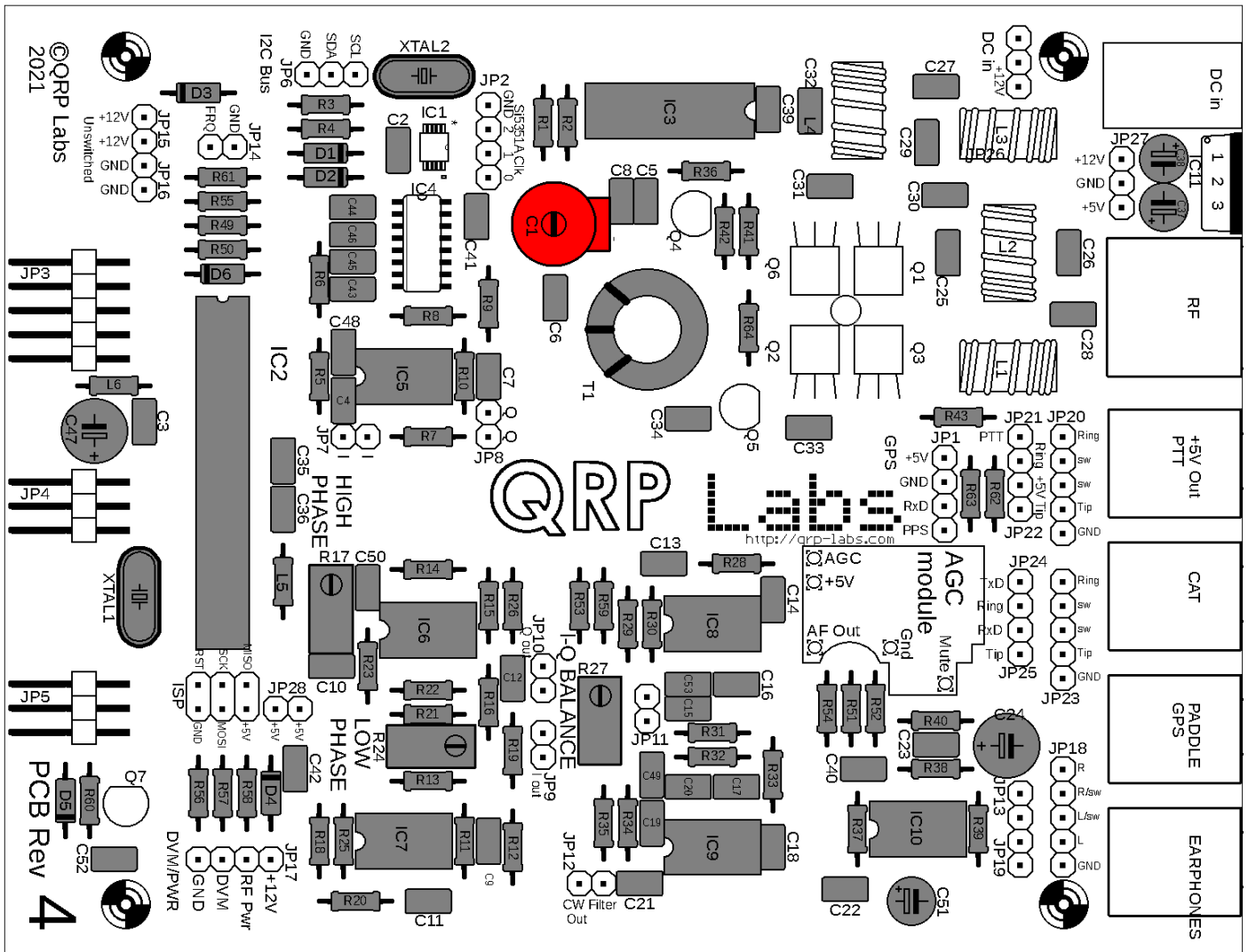

3.44 Install MPS751 transistor Q6

Be careful to correctly identify this transistor by its markings, as the package style is similar to the other transistors. Carefully bend and insert the wires so that the transistor's flat side is flat flush against the PCB surface, and the body of the transistor is aligned with the square on the layout diagram (which is not visible on the PCB silkscreen). The corner of the transistor should not overlap the PCB hole.

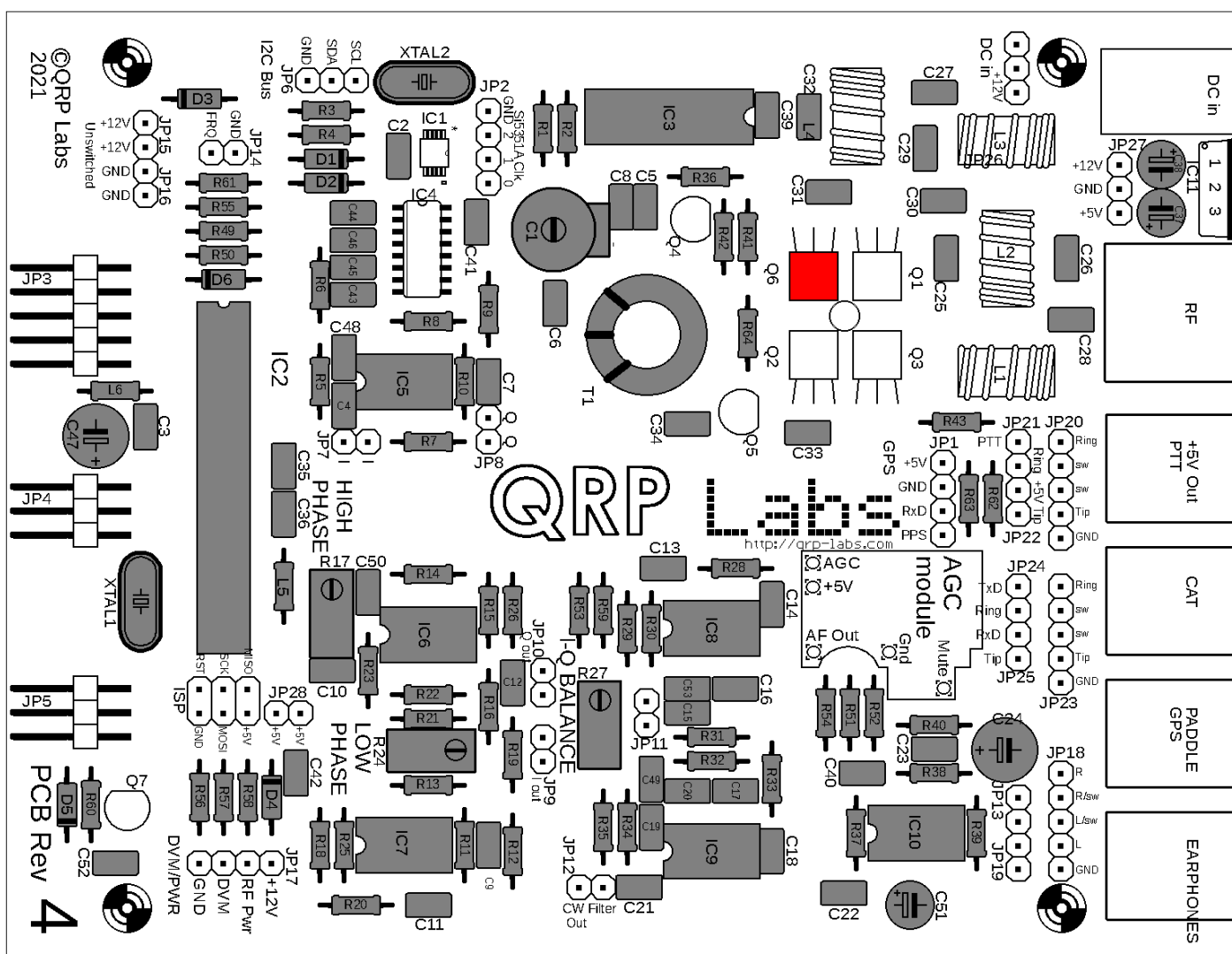
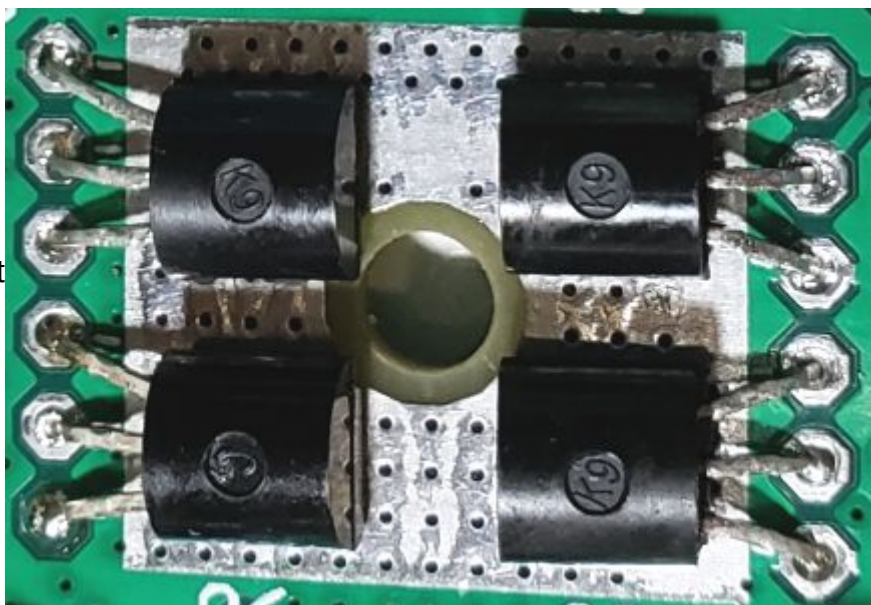

3.45 Install all BS170 transistors

The remaining transistors in the kit are BS170 MOSFETs and there are six of them: Q1, Q2, Q3, Q4, Q5 and Q7.

For Q1, Q2 and Q3, carefully follow the same installation procedure as the previous section, making sure that the transistors are neatly aligned in the correct positions near the hole in the PCB.

Q4, Q5 and Q7 must be inserted into the PCB so that the transistor body shape matches the PCB layout and silkscreen; the flat side of the transistor must line up with the straight line on the layout and silkscreen. Push the transistors into the PCB so that the lead length (between the PCB surface and the bottom of the transistor body) is about 5mm (non-critical).

After installation, use the supplied 12mm M3 steel screw, 12mm steel washer and M3 nut to bolt the transistors' flat sides firmly flat on the PCB surface, as shown (photo, right).

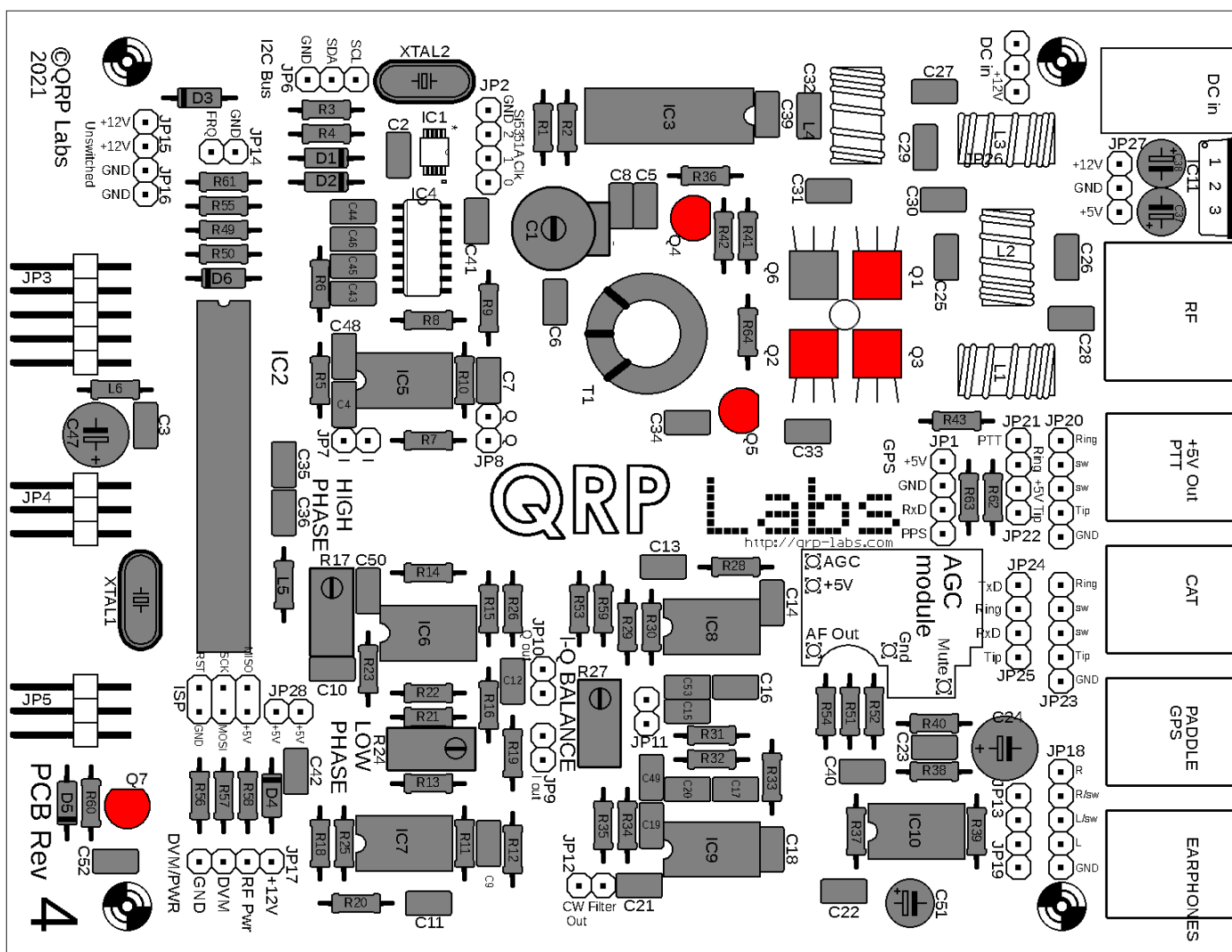

3.46 Install 2x3-pin in-circuit programming header

This male pin header can be used to connect an AVR Programmer to apply firmware updates if desired. **This is NOT the 2x3-pin female header connector socket which is later installed on the front panel display board.** Insert the SHORT end of the pins into the PCB. Solder one pin in place first and check that the header is nicely seated on the PCB before soldering the other 5.

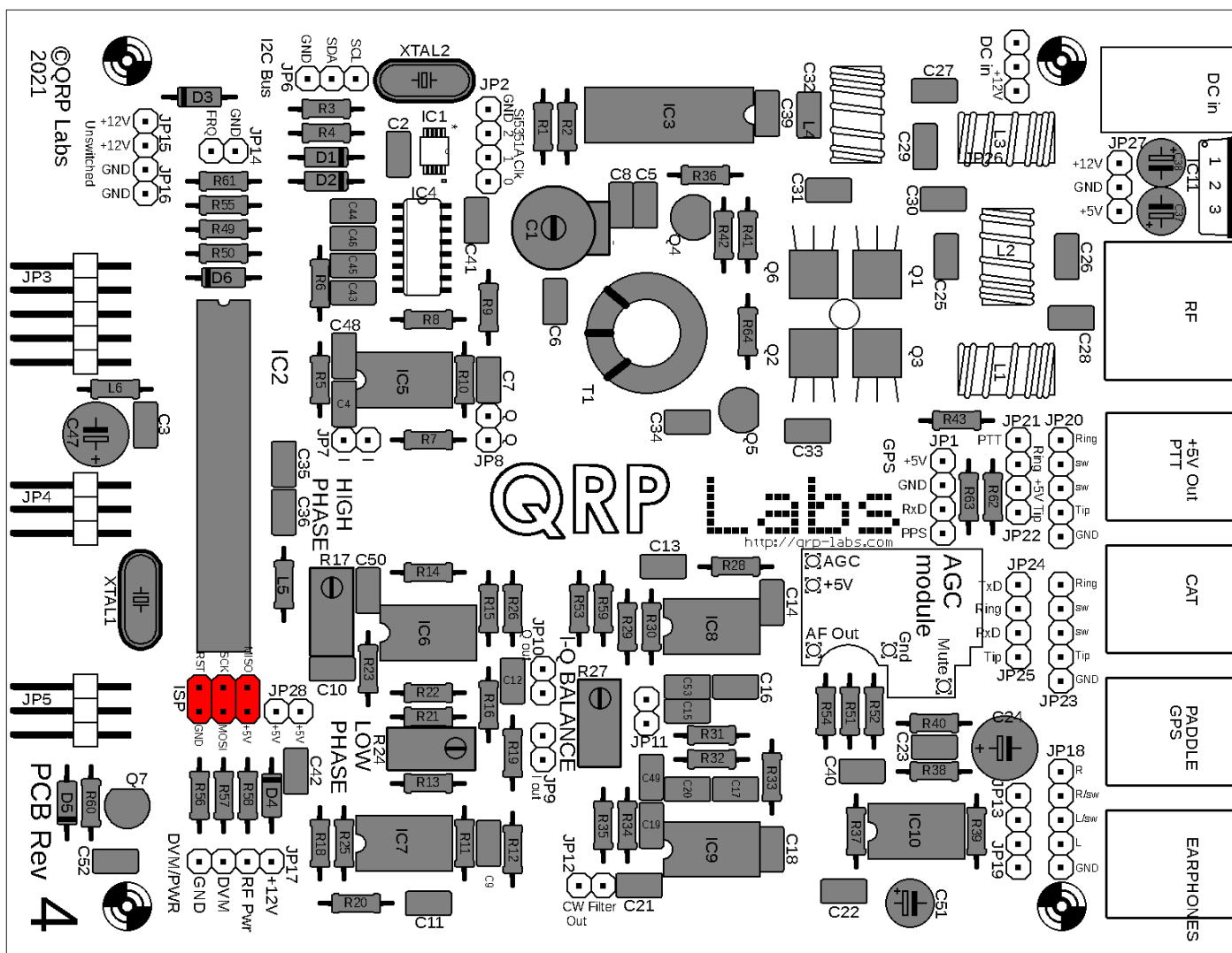

3.47 Install power connector

Install the 2.1mm power connector, orientated to match the PCB silkscreen. It is important to install this accurately so that if you install the QCX+ in the aluminium enclosure, the connector is correctly aligned with the rear panel holes.

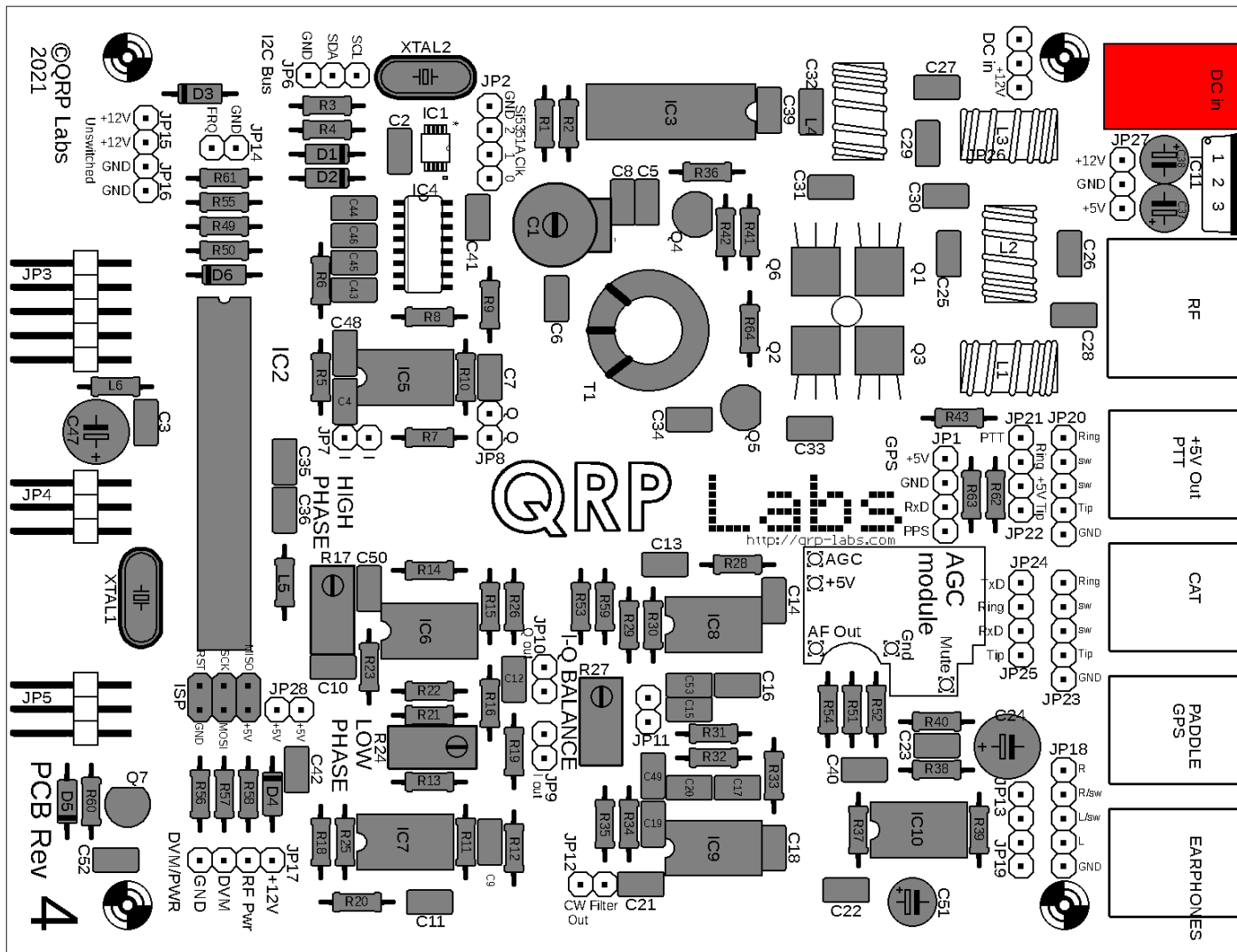

3.48 Install 7805 voltage regulator IC11

Install the 7805 voltage regulator, orientating it so that the metal tab is facing outwards from the PCB, along the edge of the PCB. Push the pins all the way down into the holes until the thicker part of the pins reaches the PCB surface. Solder and trim the excess wires under the board.

Take extra care to properly solder the center connection (ground) since the tab and ground plane will dissipate a lot of heat. Failure to solder the ground pin will result in 12V reaching the microcontroller and probably destroy it.

Use a DVM to check for continuity from the center pin to the PCB ground (e.g. put one probe in the nearby board-mounting hole which is plated and grounded).

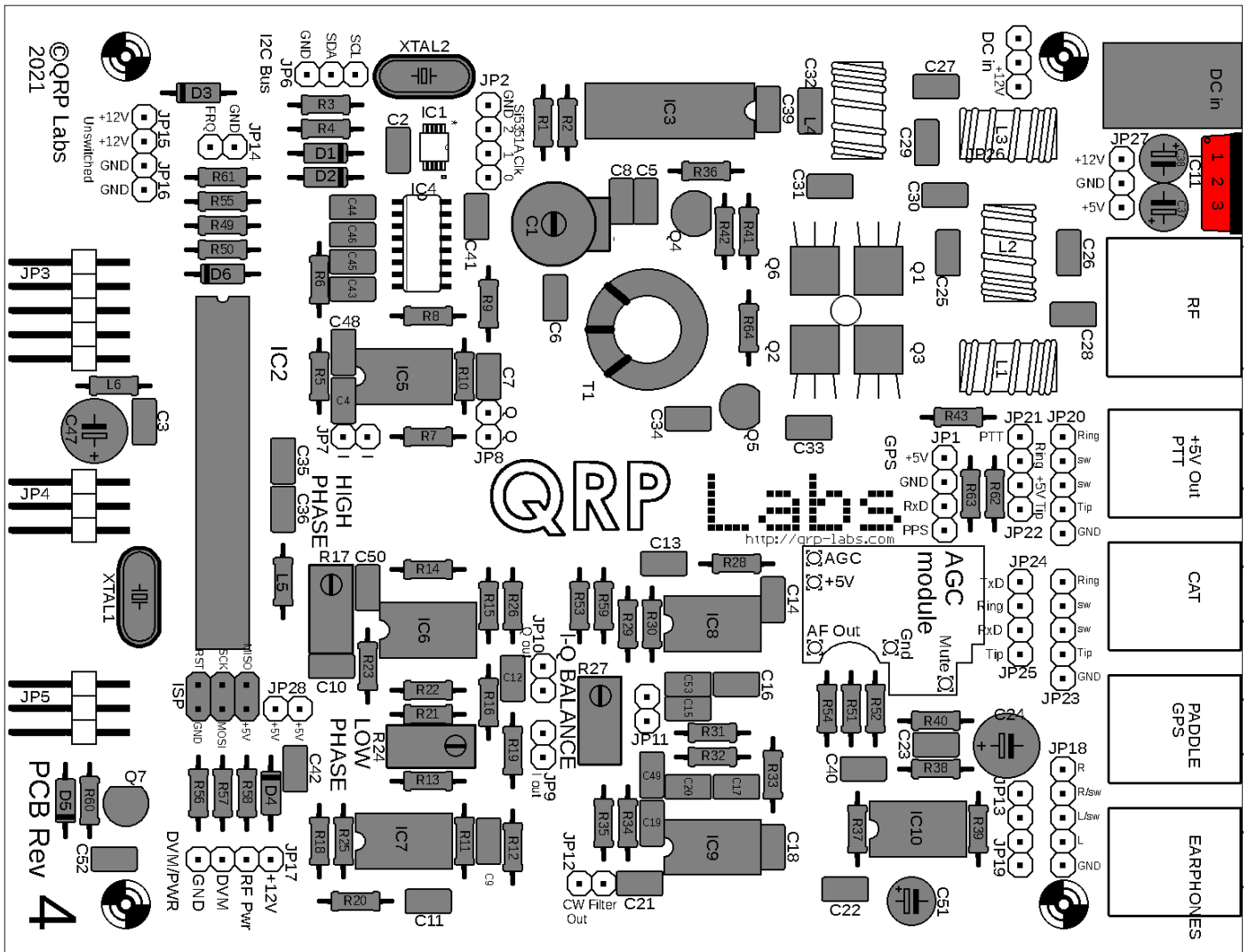

3.49 Wind and install toroid L4

L4 is type T37-2. It is a small ring with red paint on one side. Each time the wire passes through the hole in the middle of the toroid, this counts as one turn. The number of turns depends on the band of your kit, refer to the following table. Inductance values are approximate and will depend on variations in the core, and how tightly you wind the turns. Do not worry about these variations which are not critical in this case.

Band	Value	Turns
160m	1.4uH	19
80m	2.3uH	24
60m	2.3uH	24
40m	1.0uH	16
30m	0.78uH	14
20m	0.40uH	10
17m	0.32uH	9

Try to keep the wire quite tight (but not so tight that you break the wire). Try to spread the turns evenly around the toroid. Leave about 2cm or 3cm of wire at the ends.

The wire is coated with an enamel insulating paint and it is **CRITICAL to remove this enamel at the soldered joints otherwise there will be no electrical connection through the toroid! This is the number 1 cause of problems with QRP Labs kit construction: failure to remove the wire enamel.**

One method of removing the wire enamel is to scrape it off at the ends, either with sandpaper, or carefully scratching with a knife or wire cutters. However, my favourite method is just to burn off the enamel. For quite a number of years, the type of enamel used on copper wire can be burnt off using the temperature available from an ordinary soldering iron, immersing the wire in a blob of solder. (This was not the case, with much older wire found in vintage valve/tube equipment). You could also use a cigarette lighter to burn off the enamel.

Insert the ends of the wires into the correct holes of the PCB and pull it through tight, so that the toroid sits up vertically on the PCB.

Bend the wires over so that the toroid does not fall out while you are trying to solder the wires. Cut off the excess wire using wire cutters, leaving only about 2mm protruding through the PCB on the lower side. Now apply solder quite generously from the soldering iron. Hold the soldering iron to the joint for a few seconds – I usually count to 10 slowly – and the solder will surround the wire, which will become hot enough to burn off the enamel. You can sometimes see a small puff of smoke when the enamel burns off.

Carefully inspect the soldered joints with a magnifying glass to make sure that the wire is correctly soldered. If it looks like the solder hasn't flowed nicely and adhered to the wire, then this is usually a sign that the enamel probably hasn't been burnt off.

If you have a DVM it is a good idea to check for DC electrical continuity (zero ohms resistance) between the two ends of the wire. If you do NOT have a DVM and if the radio doesn't work, then we can use the built-in test equipment later, to trace the fault.

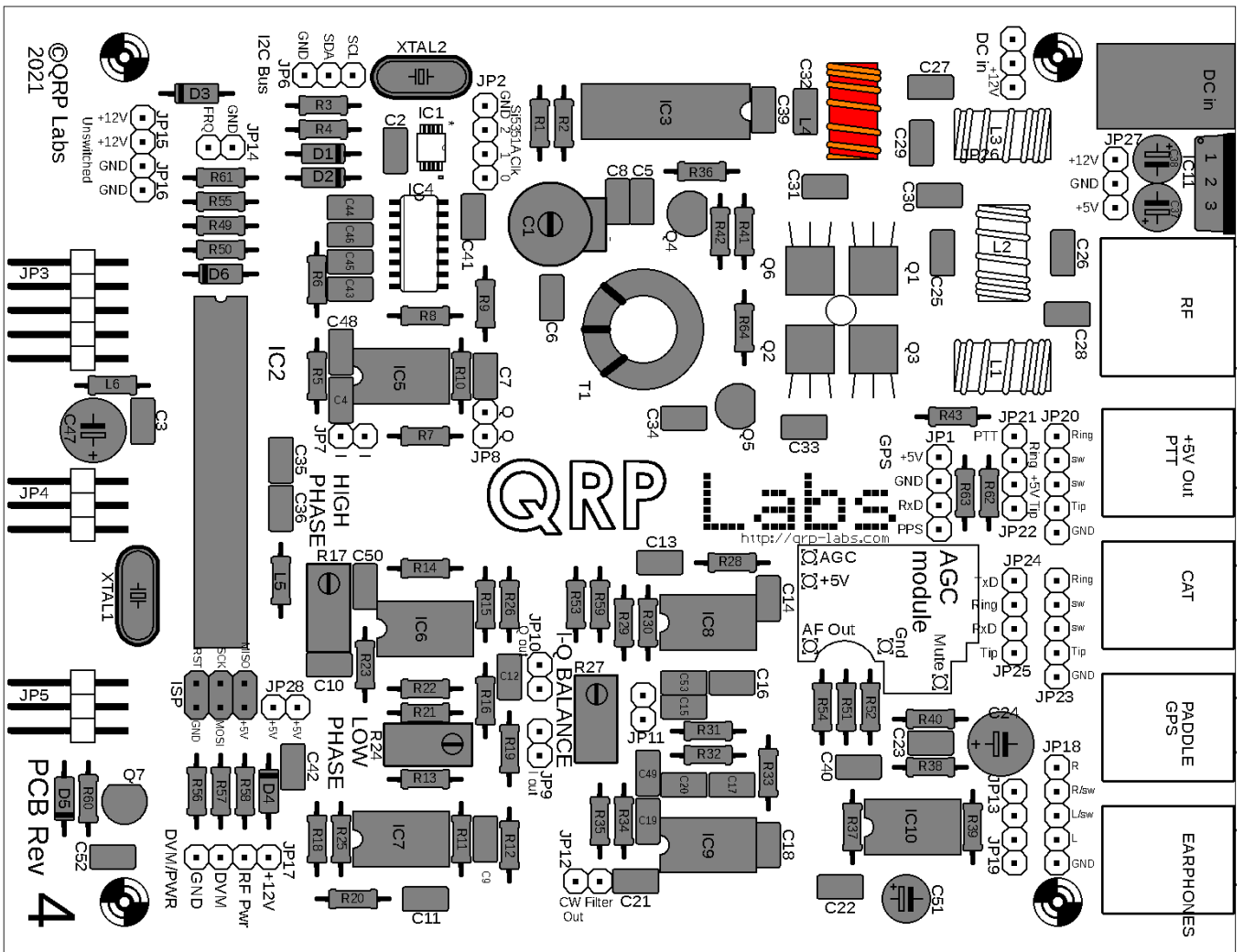

©QRP Labs
2021

PCB Rev 4

3.50 Wind and install toroid L2

L2 is a small toroid ring painted yellow or red on one side. It is part of the supplied Low Pass Filter kit bag. Again, keep the wire tight and evenly spaced around the toroid. Installation of the inductor is similar to the previous section. **Remember to remove the wire enamel and check!**

The number of turns is band-dependent, refer to the following table. Inductance values are approximate and will depend on variations in the core, and how tightly you wind the turns. Do not worry about these variations which are not critical in this case.

Band	Toroid	Colour	Value	Turns
160m	T37-2	Red	6.4uH	40
80m	T37-2	Red	3.0uH	27
60m	T37-2	Red	2.3uH	24
40m	T37-6	Yellow	1.7uH	24
30m	T37-6	Yellow	1.3uH	20
20m	T37-6	Yellow	0.90uH	17
17m	T37-6	Yellow	0.67uH	15

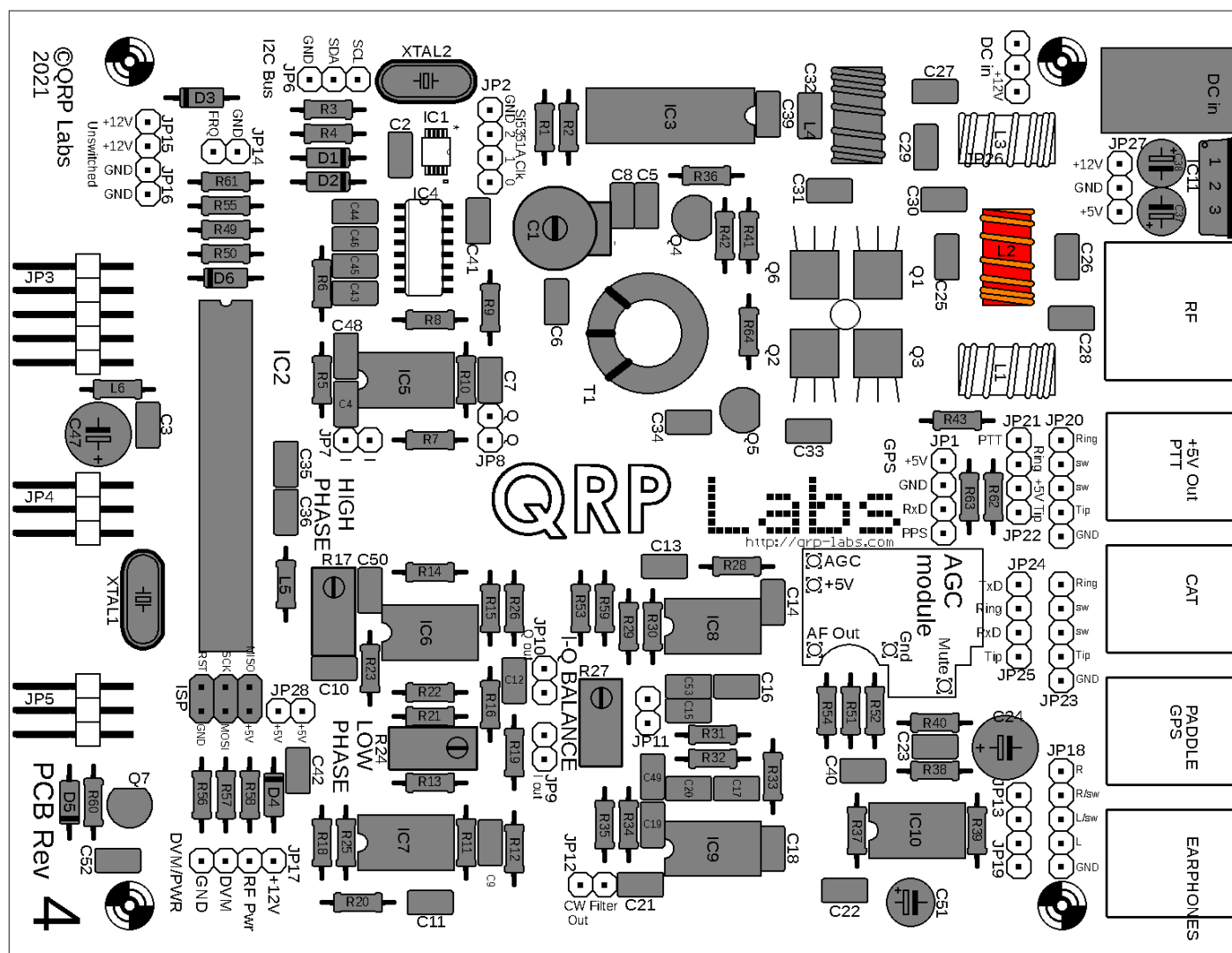

3.51 Wind and install toroids L1 and L3

L1 and L3 are small toroid rings painted yellow or red on one side. They are part of the supplied Low Pass Filter kit bag. Again, keep the wire tight and evenly spaced around the toroid. Installation of the inductor is similar to the previous section. **Remember to remove the wire enamel and check!**

The number of turns is band-dependent, refer to the following table. Inductance values are approximate and will depend on variations in the core, and how tightly you wind the turns. Do not worry about these variations which are not critical in this case.

Band	Toroid	Colour	Value	Turns
160m	T37-2	Red	3.9uH	30
80m	T37-2	Red	2.4uH	25
60m	T37-2	Red	2.1uH	23
40m	T37-6	Yellow	1.4uH	21
30m	T37-6	Yellow	1.1uH	19
20m	T37-6	Yellow	0.77uH	16
17m	T37-6	Yellow	0.55uH	13

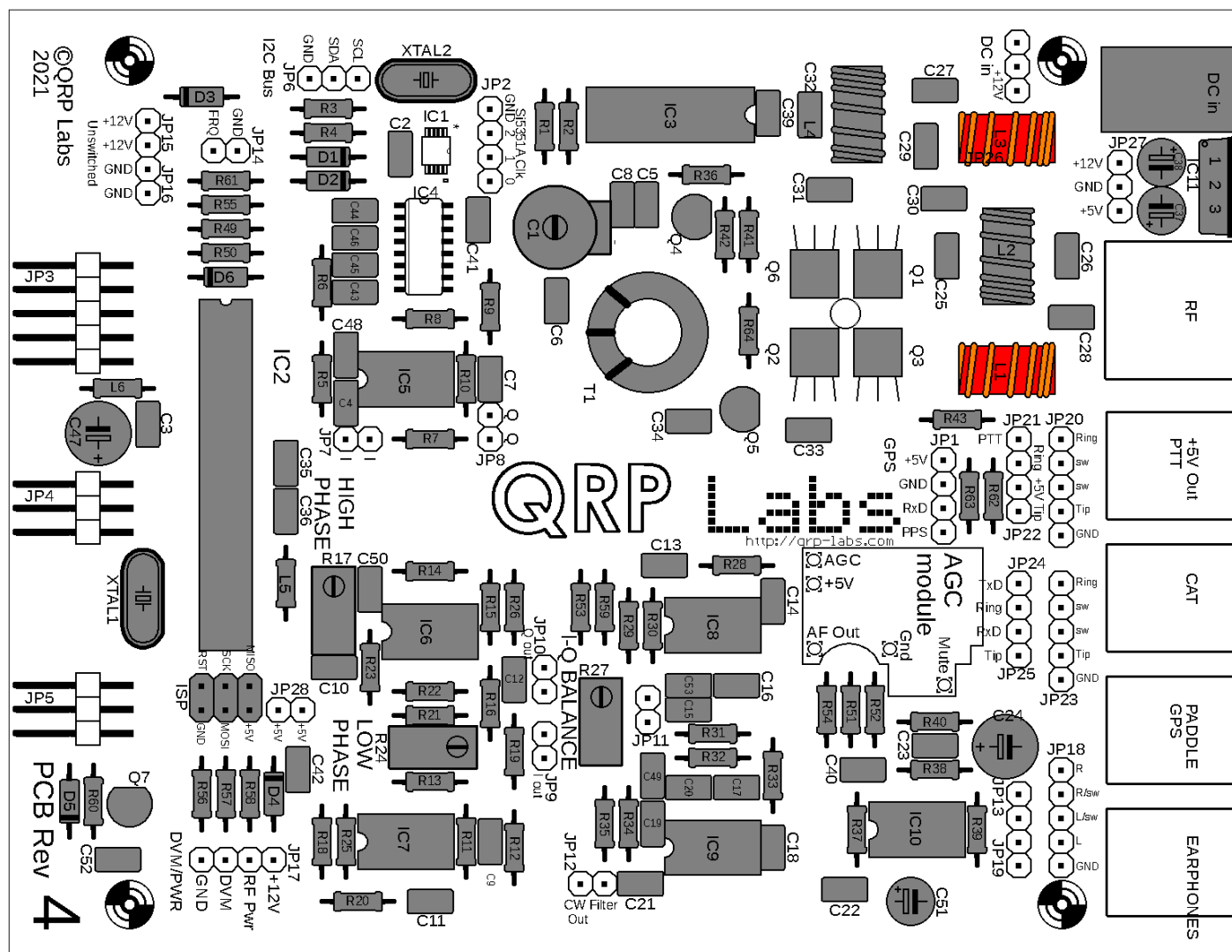

3.52 Install RF output BNC connector

Solder one pin first, to check that the alignment is correct; when happy, solder the remaining pins. The connector has RF and Ground connections, and two fat rods which are for mechanical stability only.

Accurate alignment is very important, to ensure that the connector fits into the hole of the optional QRP Labs QCX+ enclosure (if used).

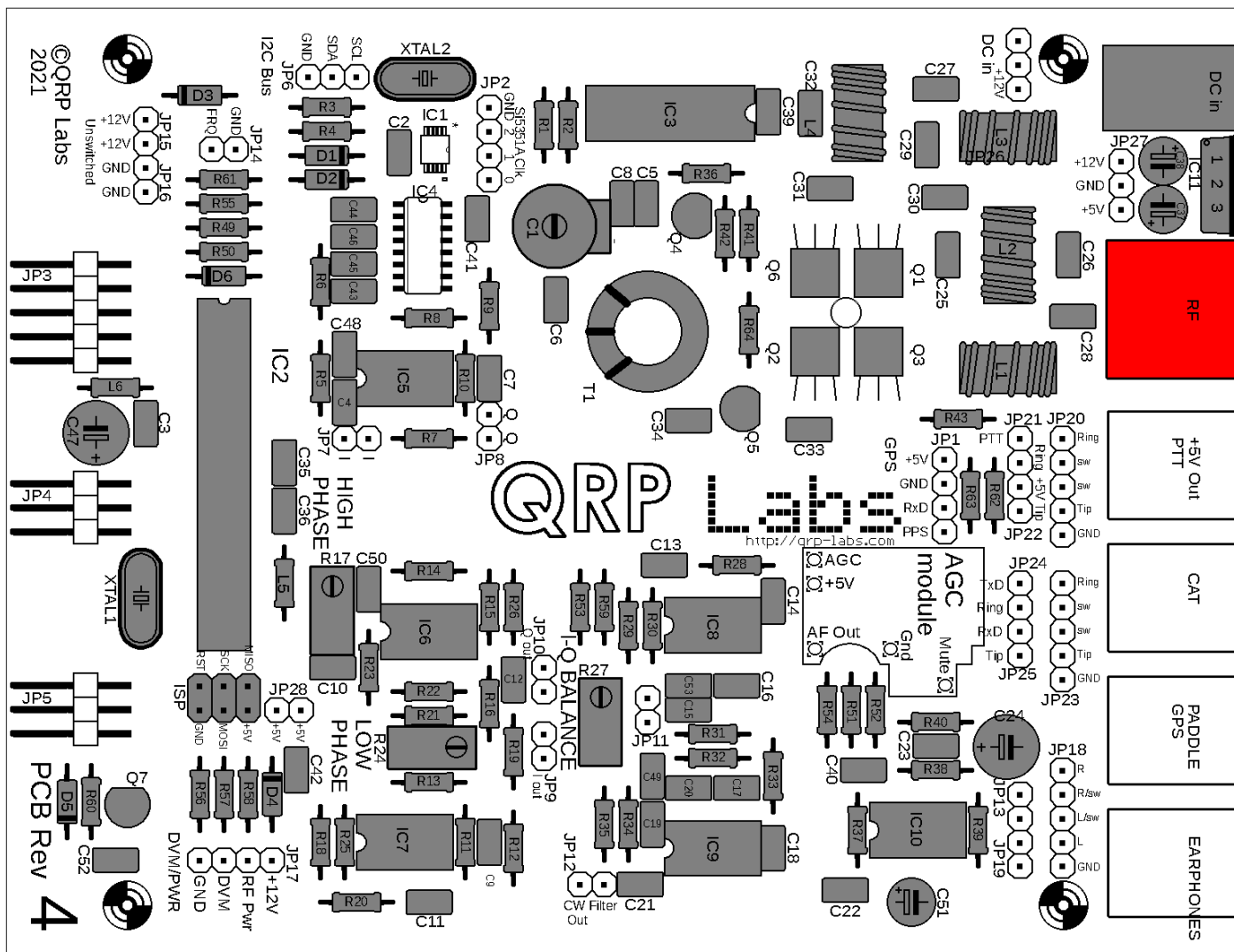

3.53 Install 3.5mm stereo jack connectors

There are four stereo 3.5mm jack connectors, used for the audio output (earphones), optional connection of a paddle, optional CAT connection, and optional PTT output to 50W PA kit (optional QRP Labs kit). The sockets may be a tight fit so insert them with care. When you are happy that the socket is neatly aligned and seated on the PCB, solder the remaining pins. Use of a larger tipped iron if available, can make this step easier.

Accurate alignment is very important, to ensure that the connectors fit into the holes of the optional QRP Labs QCX+ enclosure (if used).

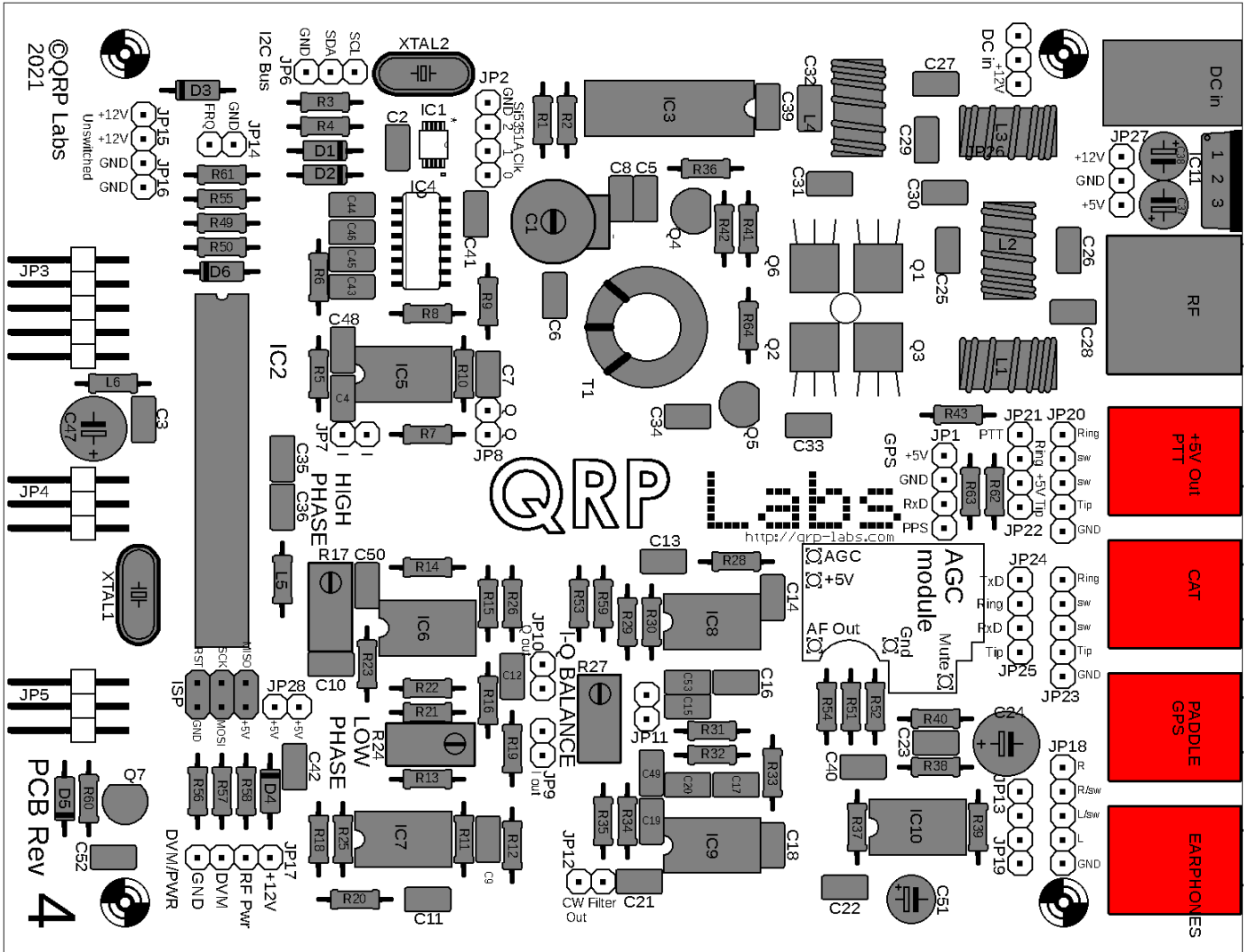

3.54 Install header pin connectors JP3, JP4 and JP5

JP3, JP4 and JP5 are right-angled 2-row header pins. They connect the main QCX+ PCB to the front-panel PCB. A 12-pin strip of 2-row header pins may be supplied. Or the pieces supplied may already have been cut. In the case of the 12-pin strip, this needs to be carefully cut into sections as follows, using a wire cutter to carefully snap the plastic strip. A heated knife blade (with a lighter, for example) can make it easier.

- JP3: 5-pin section
- JP4: 3-pin section
- JP5: 3-pin section

There will be a 1-pin section left over.

Install these very carefully so that the pins are precisely horizontal, parallel to the PCB. This is critical so that the pins align properly with the matching sockets on the front panel PCB.

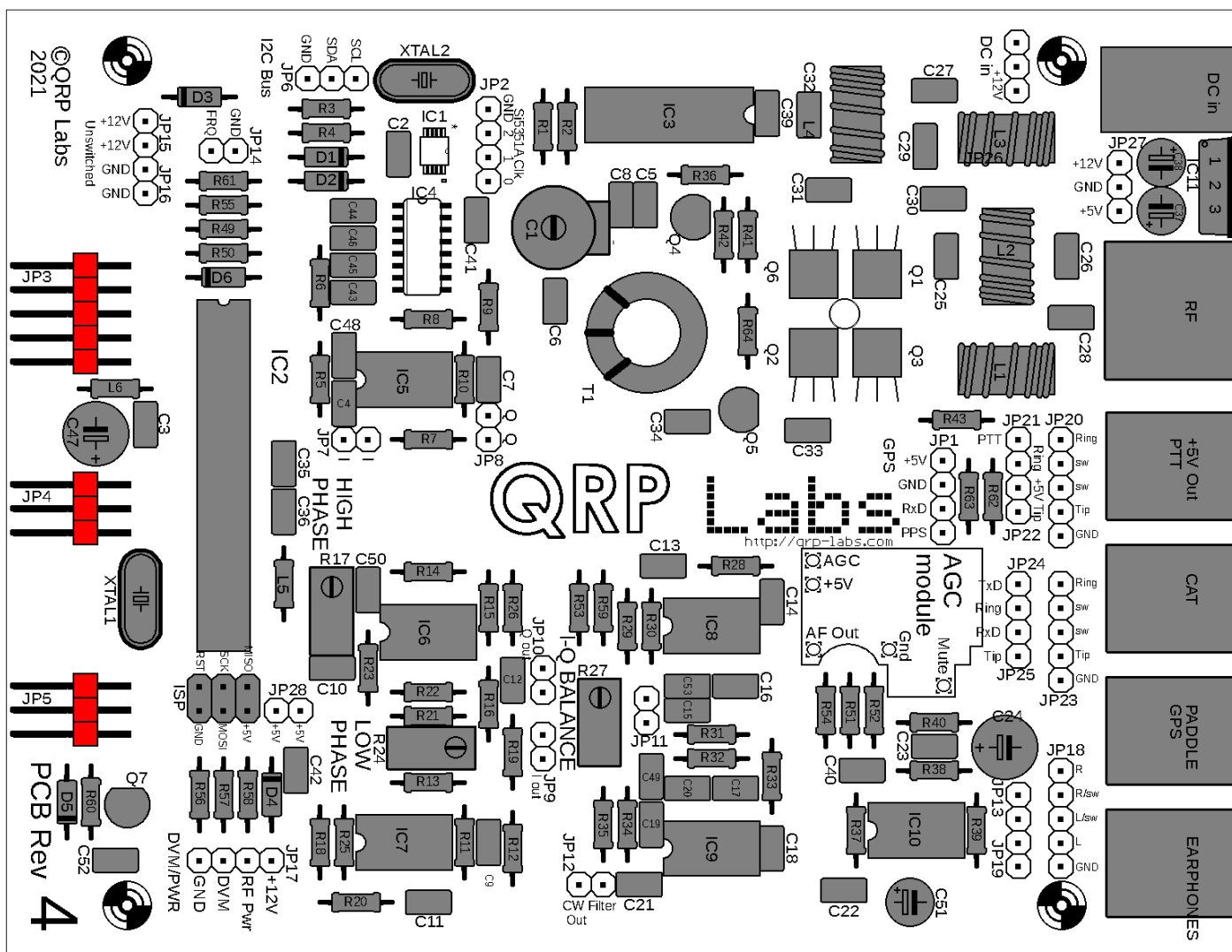

The assembly of the main QCX+ PCB is therefore now complete!

We now come to the assembly of the front panel.

Here you need to pay particular attention since some of the components are installed on the rear side of the PCB.

This photograph shows what the front panel PCB will look like, viewed from the front:

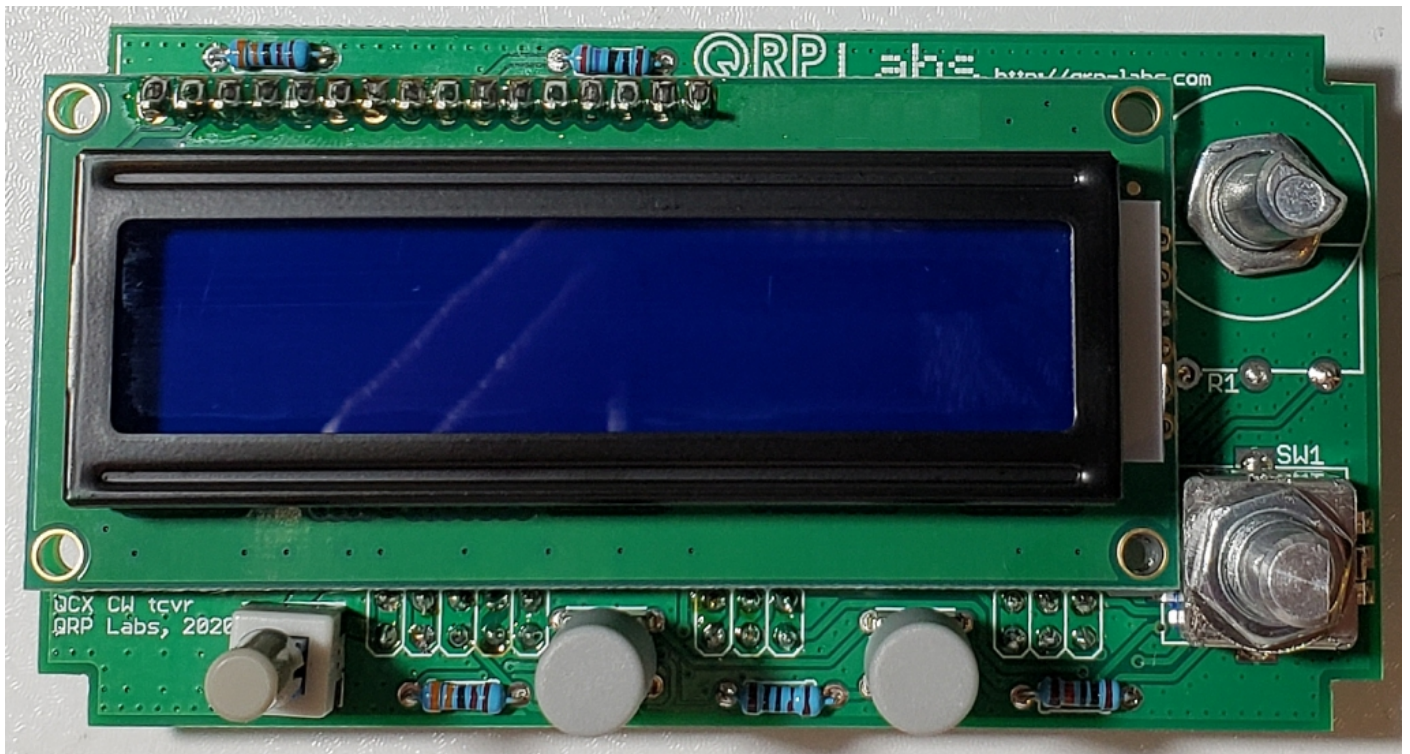

This photograph shows what the front panel PCB will look like, viewed from the rear. Notice the gain potentiometer, contrast trimmer, and pin header sockets are all on the rear side of the PCB.

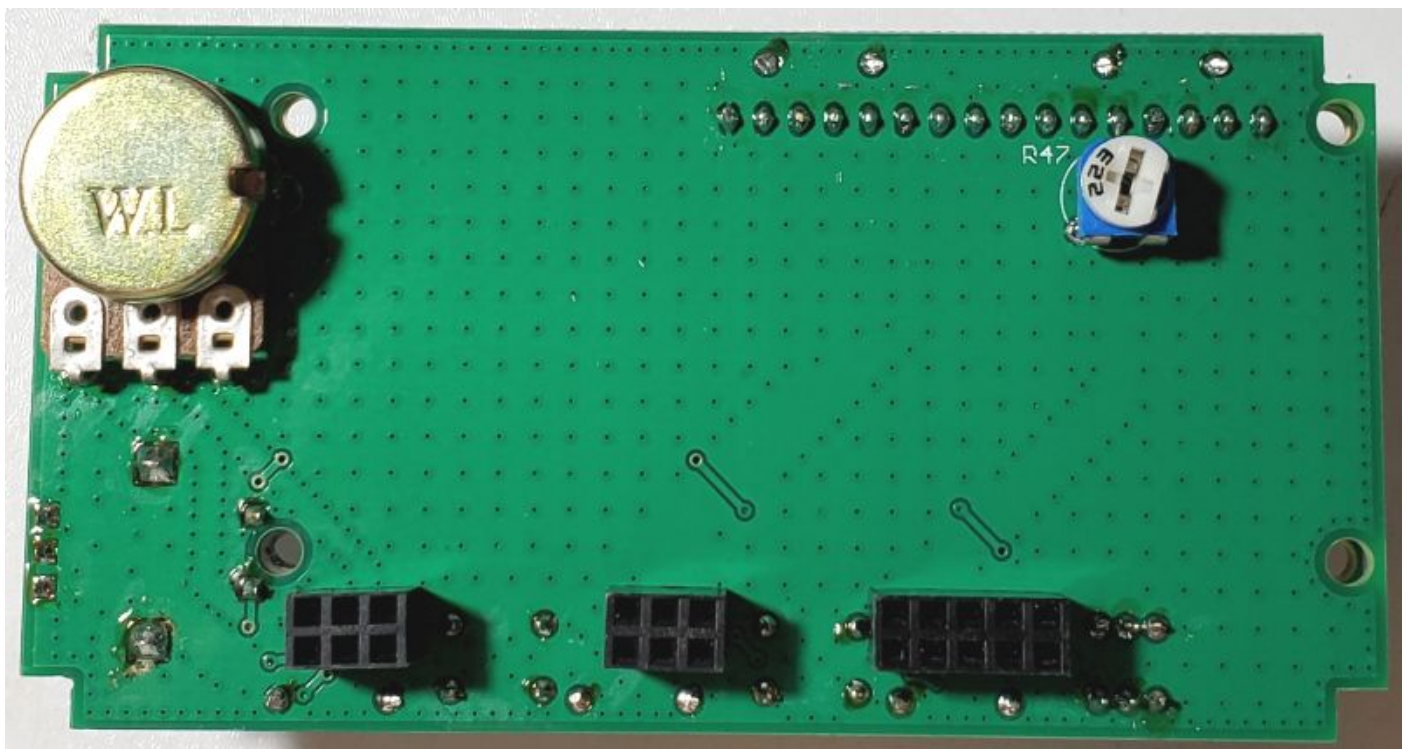

3.55 Install Front panel PCB resistors R44 and R65

R44 and R65 are 3.3K resistors. The colour code is orange-orange-black-brown-brown. Install them on the front-panel PCB as shown.

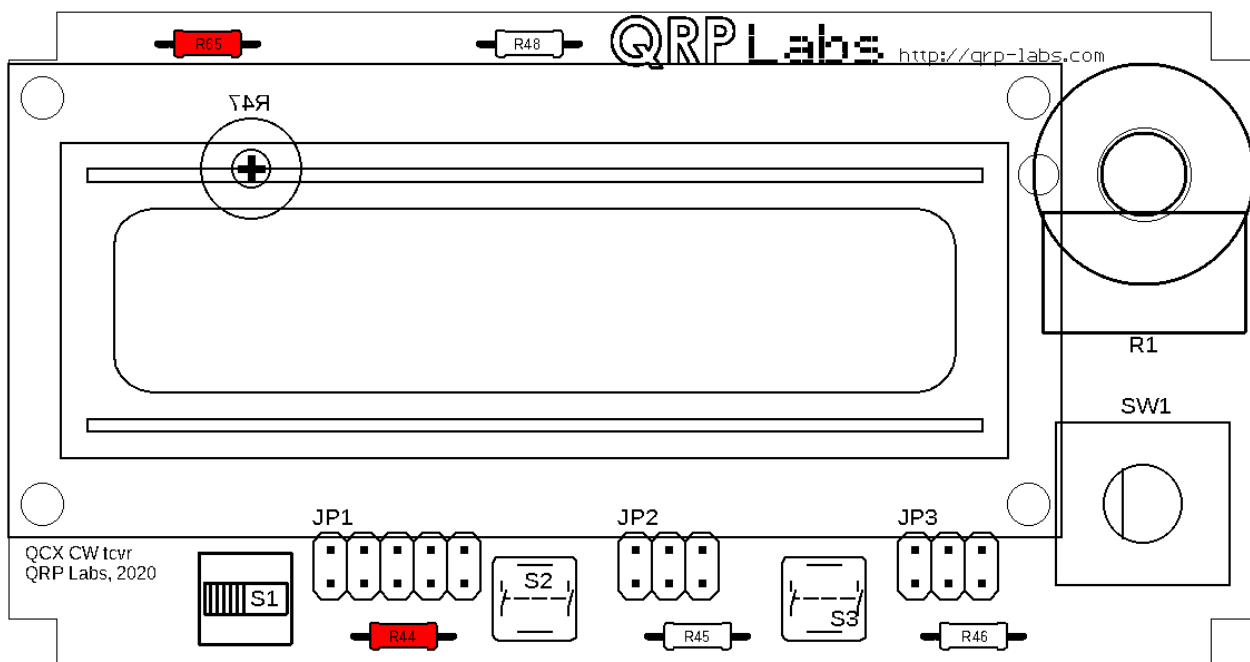

3.56 Install 270-ohm resistor R48

This resistor has colour code red-purple-black-black-brown. Note that it is a larger size than the other resistors because it is rated 0.5W dissipation. You will need to bend the leads slightly to fit under the resistor body and fit through the holes.

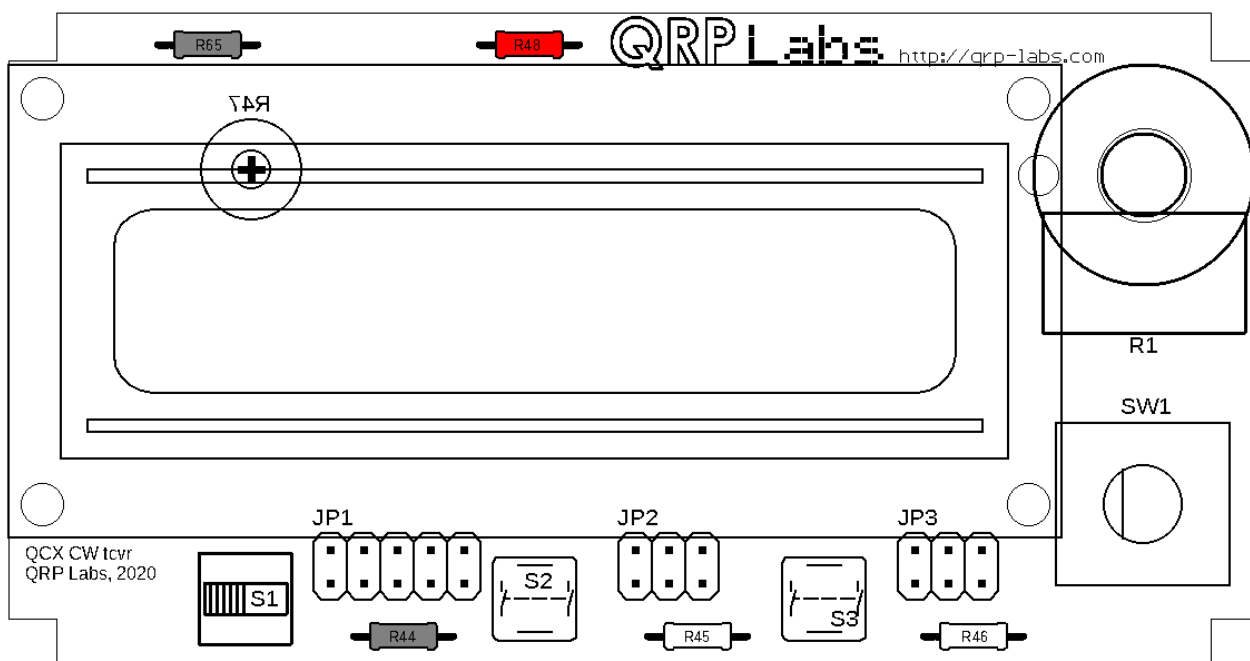

3.57 Install 1K resistor R45

This resistor has colour code brown-black-black-brown-brown.

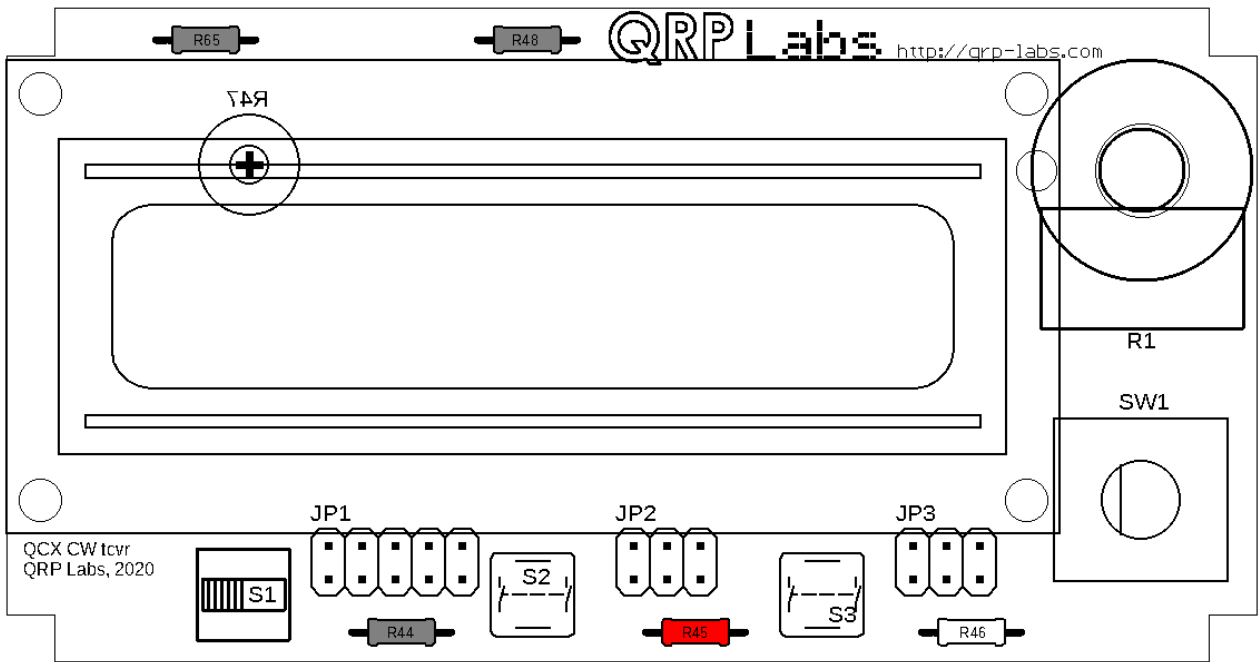

3.58 Install 10K resistor R46

This resistor has colour code brown-black-black-red-brown.

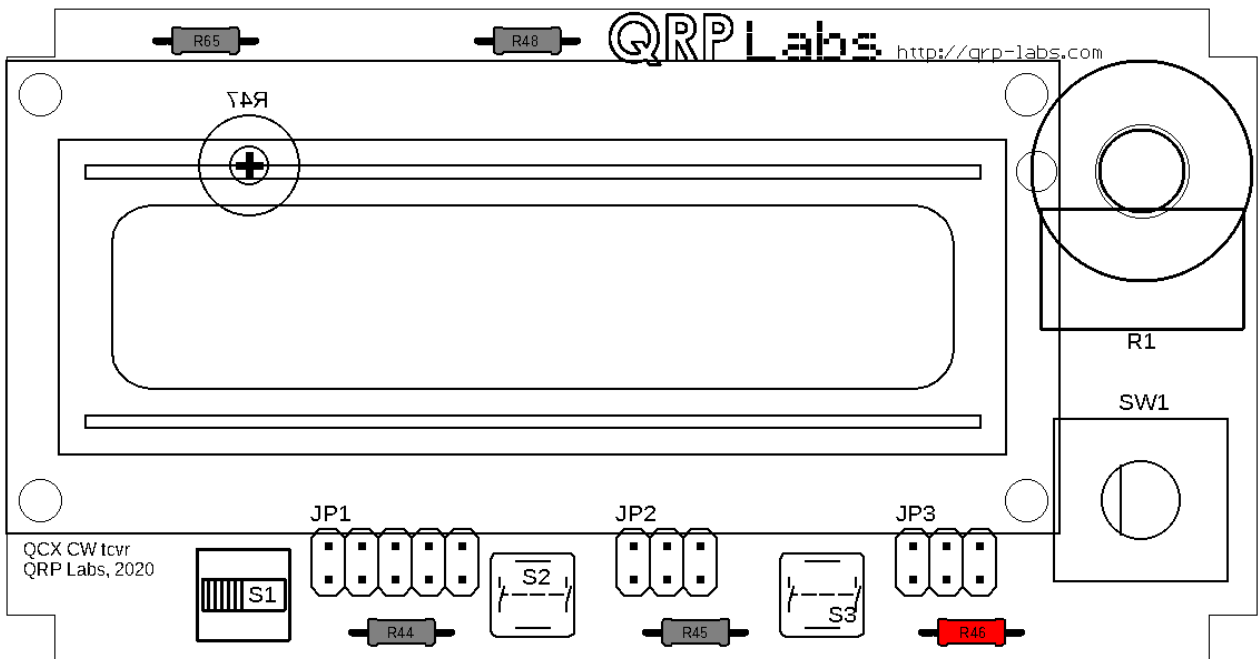

3.59 Install 2x5-pin header connector socket JP1

This 2x5-pin header must be installed on the BOTTOM side of the front panel PCB!

Install the 2x5-pin header connector socket on the reverse (bottom) side of the PCB, it will be connected to the pin header plugs on the main rear QCX+ PCB. Be very careful to solder this on the correct side of the PCB, it will be impossible to remove afterwards if you get it wrong now. The pins can be a little harder to solder and may benefit from higher iron temperature.

The connector body is on the bottom side of the PCB, the soldering is to be done on the front side of the PCB!

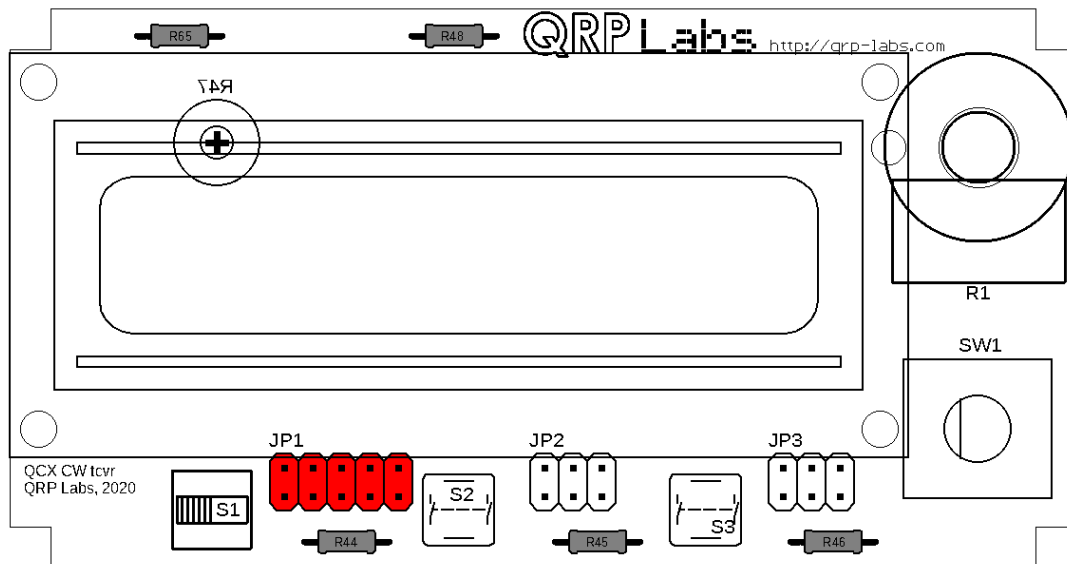

3.60 Install two 2x3-pin header connector socket JP2 and JP3

This 2x3-pin headers must be installed on the BOTTOM side of the front panel PCB!

Install the two 2x3-pin header connector sockets on the reverse (bottom) side of the PCB, they will be connected to the pin header plugs on the main rear QCX+ PCB. See previous section, install these two in the same way. **Be very careful to solder this on the correct side of the PCB, it will be impossible to remove afterwards if you get it wrong now.**

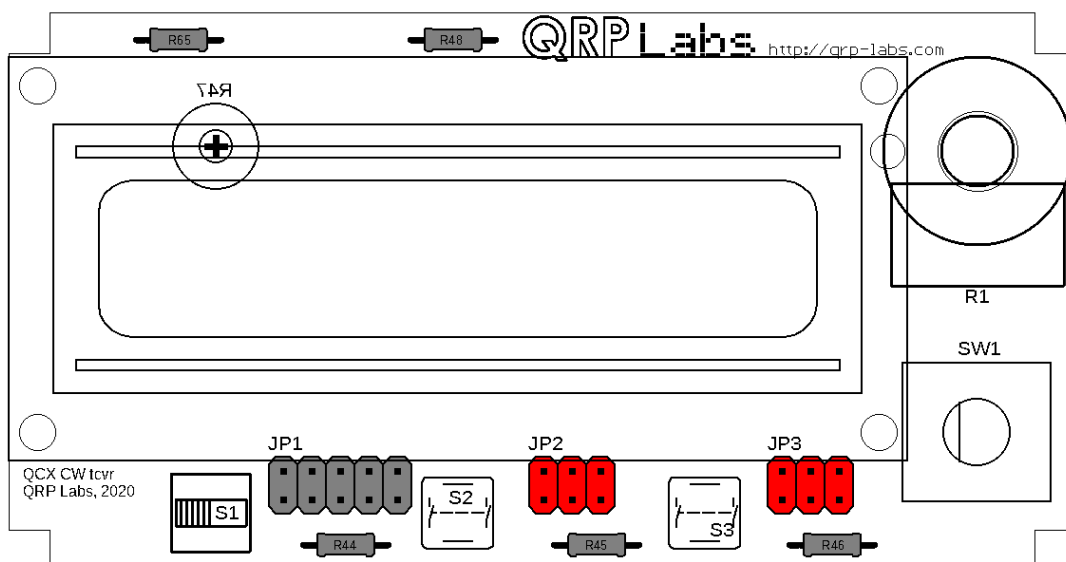

3.61 Install 22K trimmer potentiometer R47

The 22K trimmer potentiometer must again be installed with the body on the reverse (bottom) side of the front panel PCB.

Solder the pins carefully on the top (front) side of the PCB. This trimmer potentiometer is under the LCD module so it has to be fitted on the reverse side of the PCB.

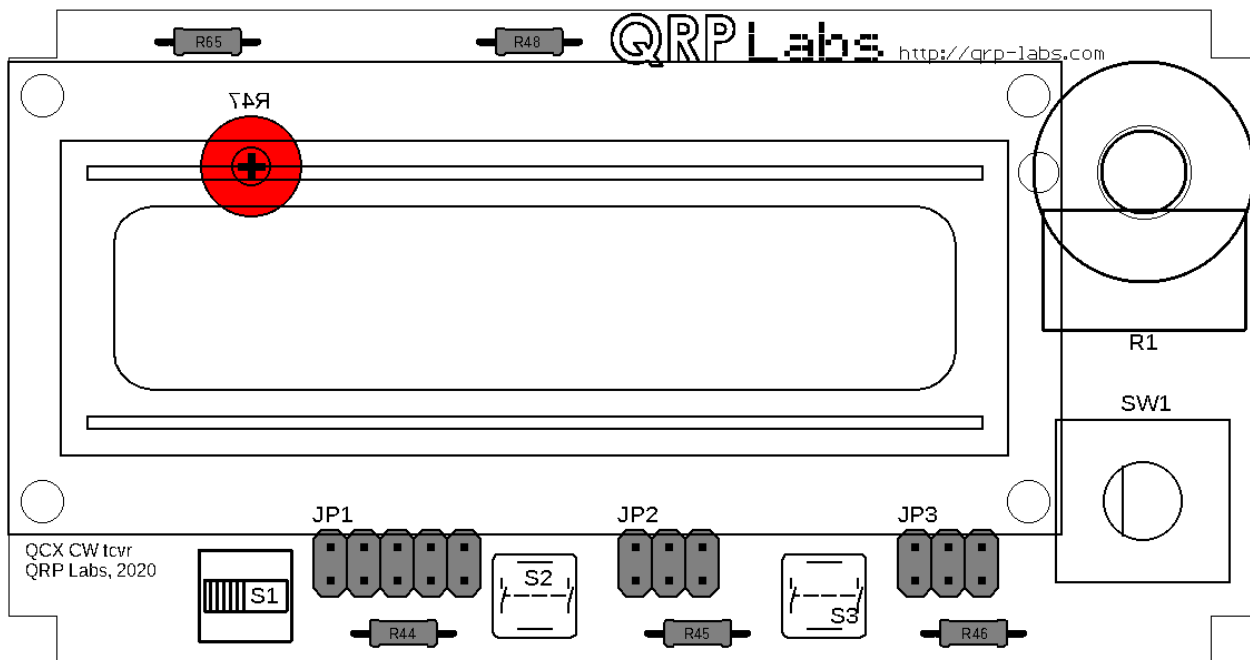

3.62 Install button switches S2 and S3

Install the two 6x6x12mm tactile button switches as shown. Fit the button caps to the buttons.

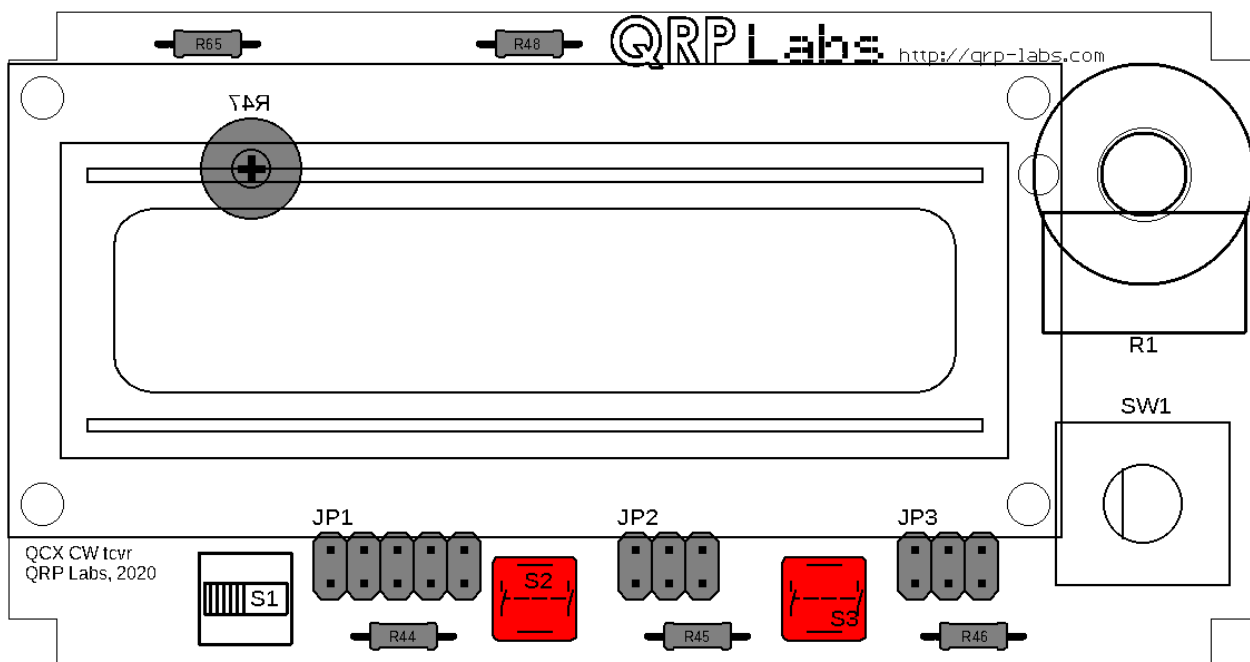

3.63 Install On/Off switch S1

The On/Off switch has to be orientated the correct way, so that pushing the button in is "ON" and the button out position is "OFF". Correct orientation is when the indentation pattern in the blue button body is right-hand side of the board when viewed from the front of the PCB assembly.

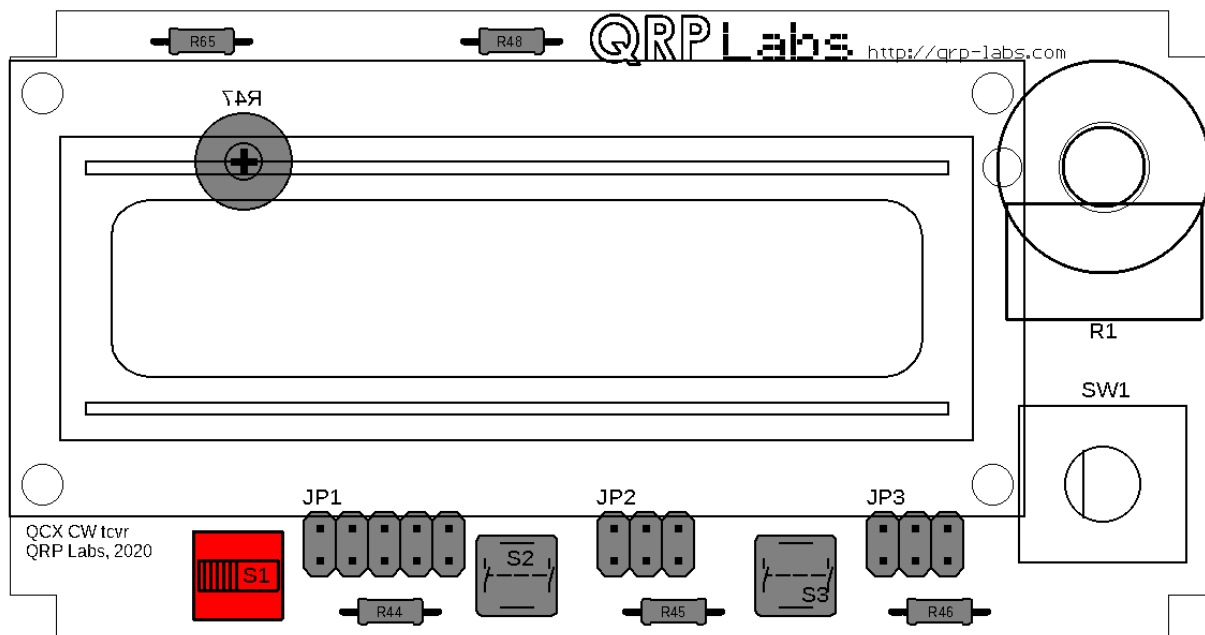
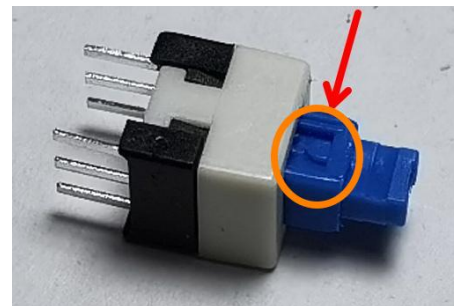

3.64 Install rotary encoder

This switch has seven solder pads: five are for electrical connections and the two large tabs are for mechanical stability. The large ground tab connections require more heat to get a good joint.

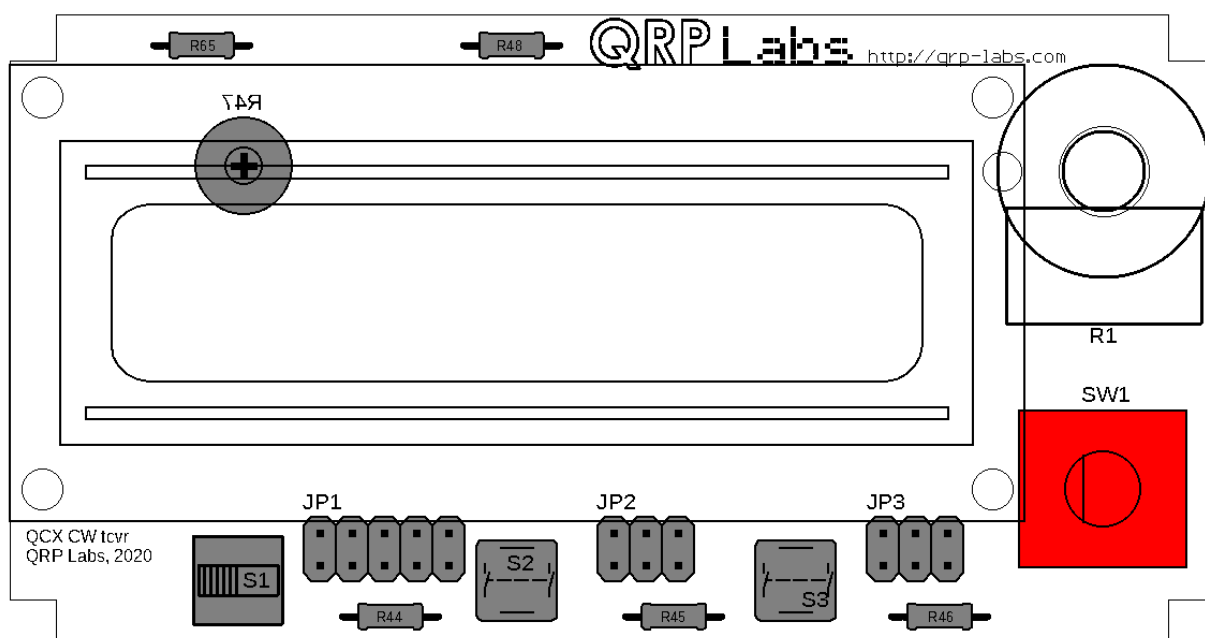

3.65 Install gain control potentiometer

Remove the nut from the potentiometer, fit the shaft through the hole in the PCB, and carefully install the bolt and tighten with pliers. There is an anti-rotation tab on the metal case, which fits in the smaller hole to the left of the main shaft hole. When tightening the nut ensure that the pins remain aligned with the corresponding pads on the PCB.

Be very careful with this potentiometer and do not over-tighten the nut. The potentiometer is quite delicate.

Solder three component lead offcuts into the holes on the PCB, and solder the other end of each one to the gain potentiometer terminals.

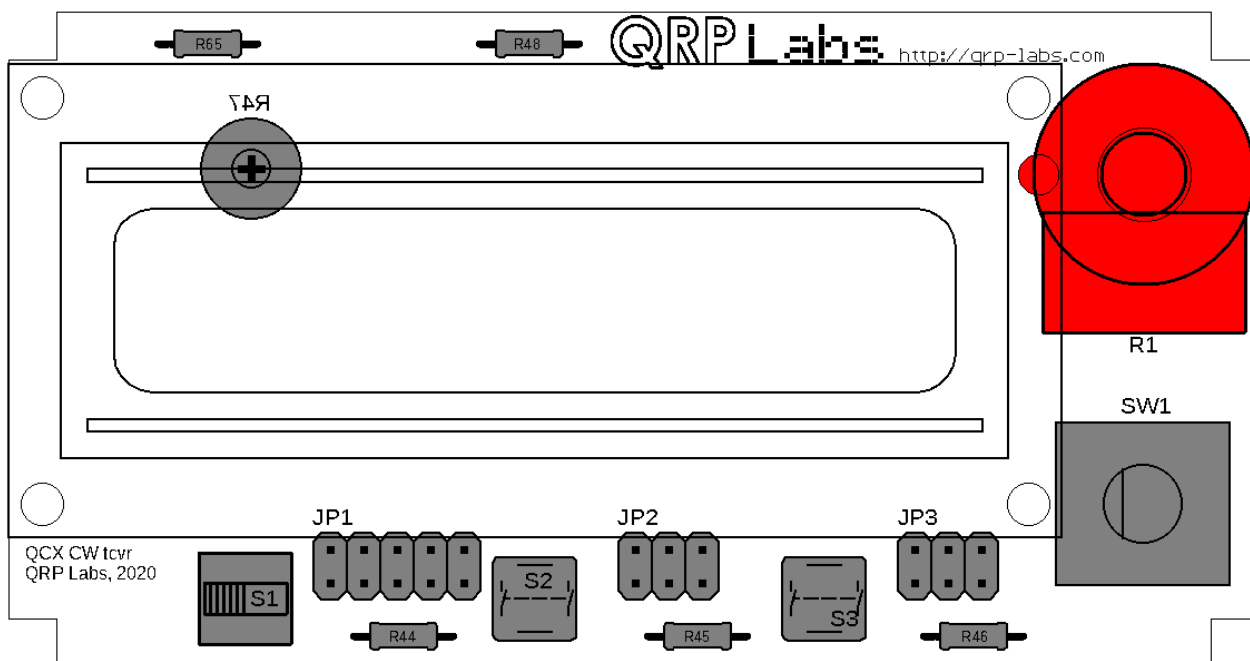

3.66 Install LCD module

The LCD module is soldered in place, it does not plug in using connectors. The 1x16-pin header connector is used to form the wiring between the front panel PCB and the LCD module, in the position indicated in orange in the diagram below.

To achieve the correct spacing, insert two black 20mm M3 screws in the two holes of the LCD coloured in red in the diagram below. Thread a nylon M3 nut onto each screw. Push the screws into the corresponding holes on the front panel PCB, with the 1x16-pin header body sandwiched between the LCD module and the front panel PCB. Orient the 1x16-pin header with the short-end of the pins protruding from the front of the LCD module, and the long-end of the pins coming from the back of the front panel PCB. Then add nylon M3 nuts to bolt the LCD module securely in place with the correct spacing.

It is not necessary at this stage to fit the two screws that will secure the bottom two corners of the LCD module to the front panel PCB. Since the screws must anyway be removed again (assuming you will install your QCX+ in the official QCX+ enclosure), fitting those two screws is not necessary at this stage. However if you are planning to use your own enclosure then you can fit them if you wish. Note that the screw next to SW1 (the rotary encoder) is a tight fit, because of the pins of the rotary encoder. But it DOES fit, with patience.

Once the LCD module is bolted in place, with the 1x16-pin header in the middle, you can solder the pins on either side: on the front side of the LCD module and on the rear side of the front panel PCB.

Note that the center 4 pins of the LCD module are not connected to anything. If you wish, you may omit these. In that case you may cut the 1x16-pin header strip into three pieces:

- 1x6-pin section for pins 1-6 of the LCD module, at the left
- 1x6-pin section for pins 11-16 of the LCD module, at the right
- 1x4-pin section, leaving a gap right in the middle, then you can use that 4-pin header elsewhere in the project if you wish; for example, at the DVM/RF Power header connector on the main board.

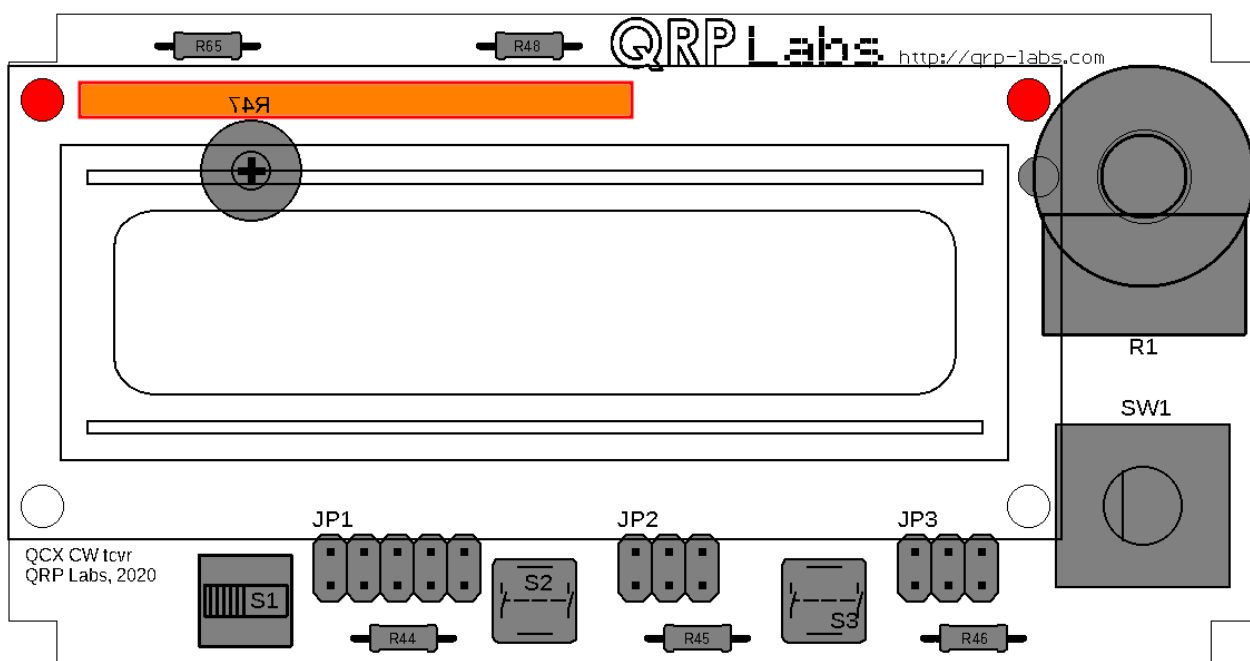

3.67 Install knobs

Two black knobs are supplied, one for the rotary encoder and one for the gain control. When fitting the gain control knob, you should ensure that when the potentiometer is turned all the way anti-clockwise, the white pointer on the knob points to the bottom left corner of the PCB. This is the conventional alignment for volume control knobs.

If you are installing your QCX+ in the official QCX+ enclosure, you will need to fit the knobs AFTER the radio has been installed in the enclosure. If you wish to test while the radio is not in its enclosure, you can fit them temporarily now.

3.68 Install optional AGC module

If you have purchased and plan to install the optional AGC module, please refer to the appropriate section of the assembly instructions in the AGC board manual from <http://qrp-labs.com/agc>

3.69 Install optional TCXO module

To install the TCXO module requires that XTAL2 (27MHz crystal) and C2 (0.1uF capacitor, code "104") are not installed. If this is a retro-fit then you need to remove C2 and XTAL2 and ideally clean out the holes. Or, you could simply heat the holes and insert component off-cut wires into them.

The tiny TCXO module PCB will fit onto the XTAL2 position as shown, replacing the 27MHz crystal. There is a cut-out window in the TCXO module, which fits over IC1 (Si5351A).

The TCXO module PCB should be installed such that it sits flush on the surface of the main QCX+ PCB. Note that the TCXO module is a 0.8mm thick PCB and is single-sided. The pads are quite delicate and it will not tolerate being de-soldered and re-soldered. In other words you need to be very careful to get this right the first time.

The TCXO module requires three connections: OUT, VDD and GND, as shown in the diagram below. Use three off-cut component wires such as from resistors, for this purpose. Insert them through the holes and solder on the bottom side of the QCX+ PCB and on the top side of the TCXO module PCB.

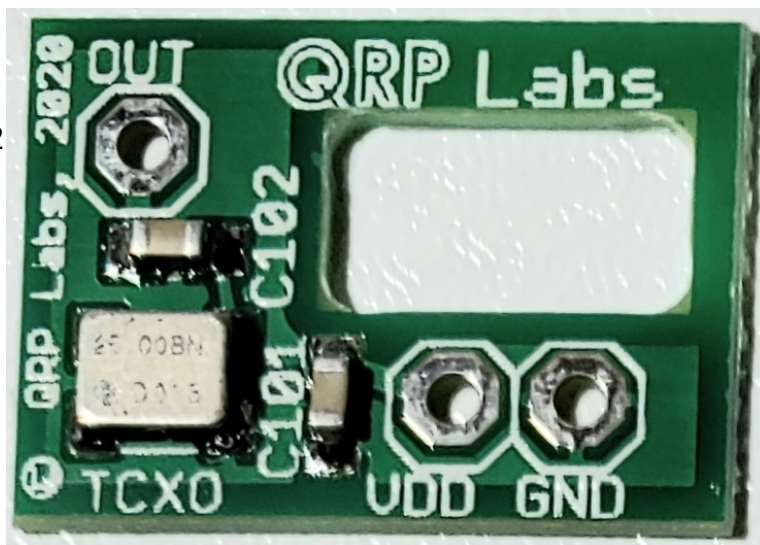

Note that when using the TCXO module, the reference frequency setting must be 25,000,000 MHz, not the default which is 27,004,000 MHz. This is further described in the initial set-up instructions, below. This is because the QCX+ can operate either with 25MHz reference (the TCXO module) or with 27MHz (the supplied crystal), BUT, you have to tell it which one you have installed!

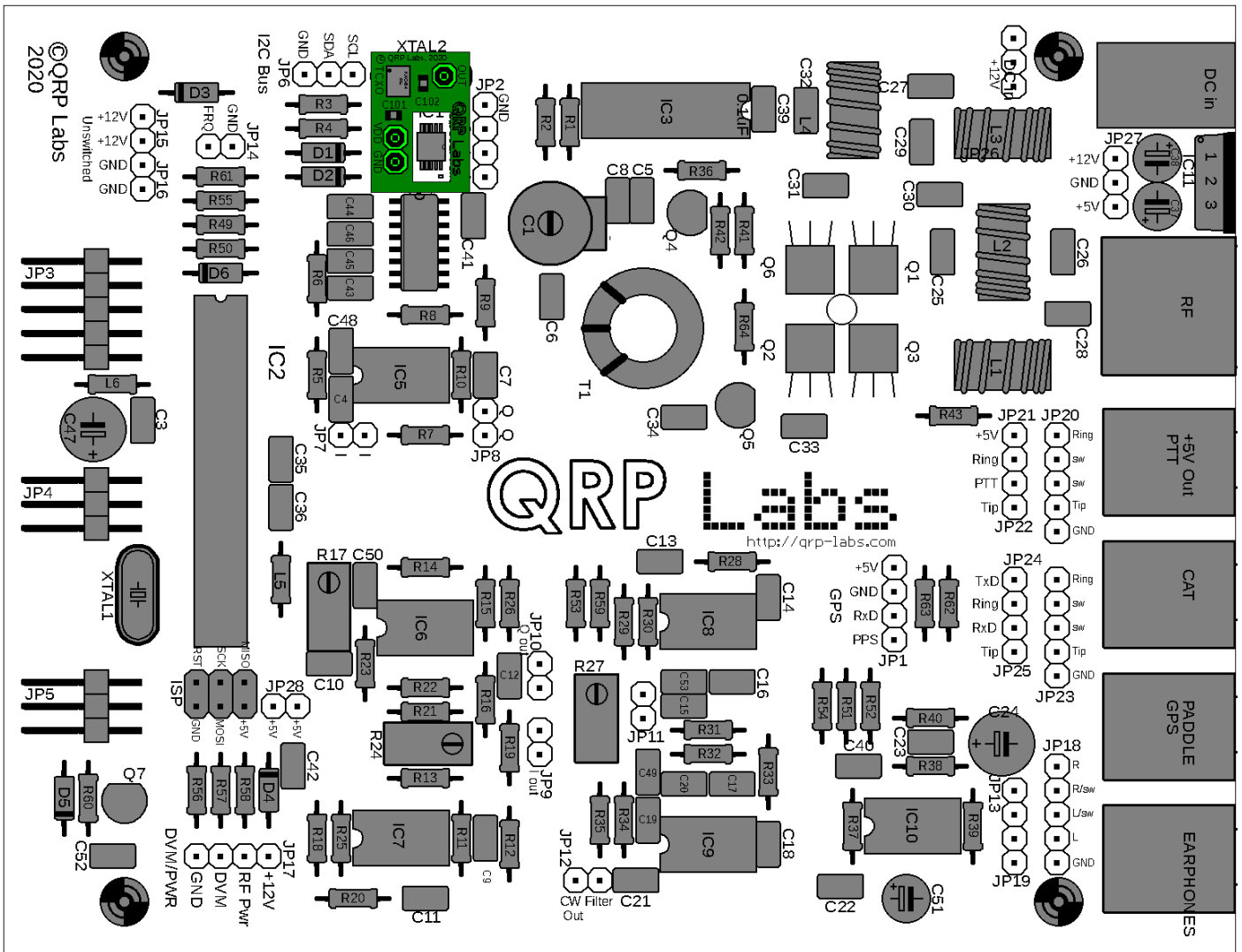

Photograph when viewed from the front of the radio:

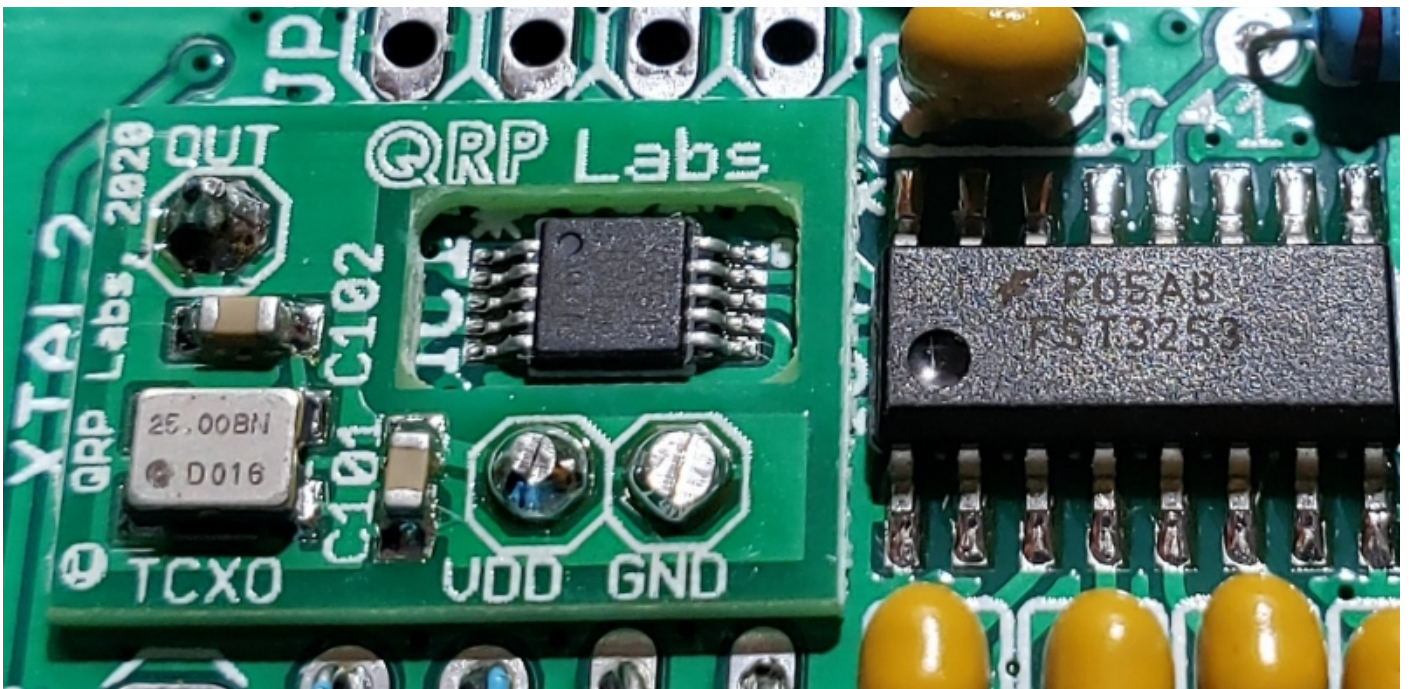

3.70 Install microcontroller

Install IC2, the programmed ATmega328P microcontroller, in the 28-pin DIP socket on the main QCX+ PCB. Be very careful to ensure that the dimple on the chip is aligned with the dimple on the 28-pin DIP socket, which itself should already be aligned with the dimple on the PCB silkscreen.

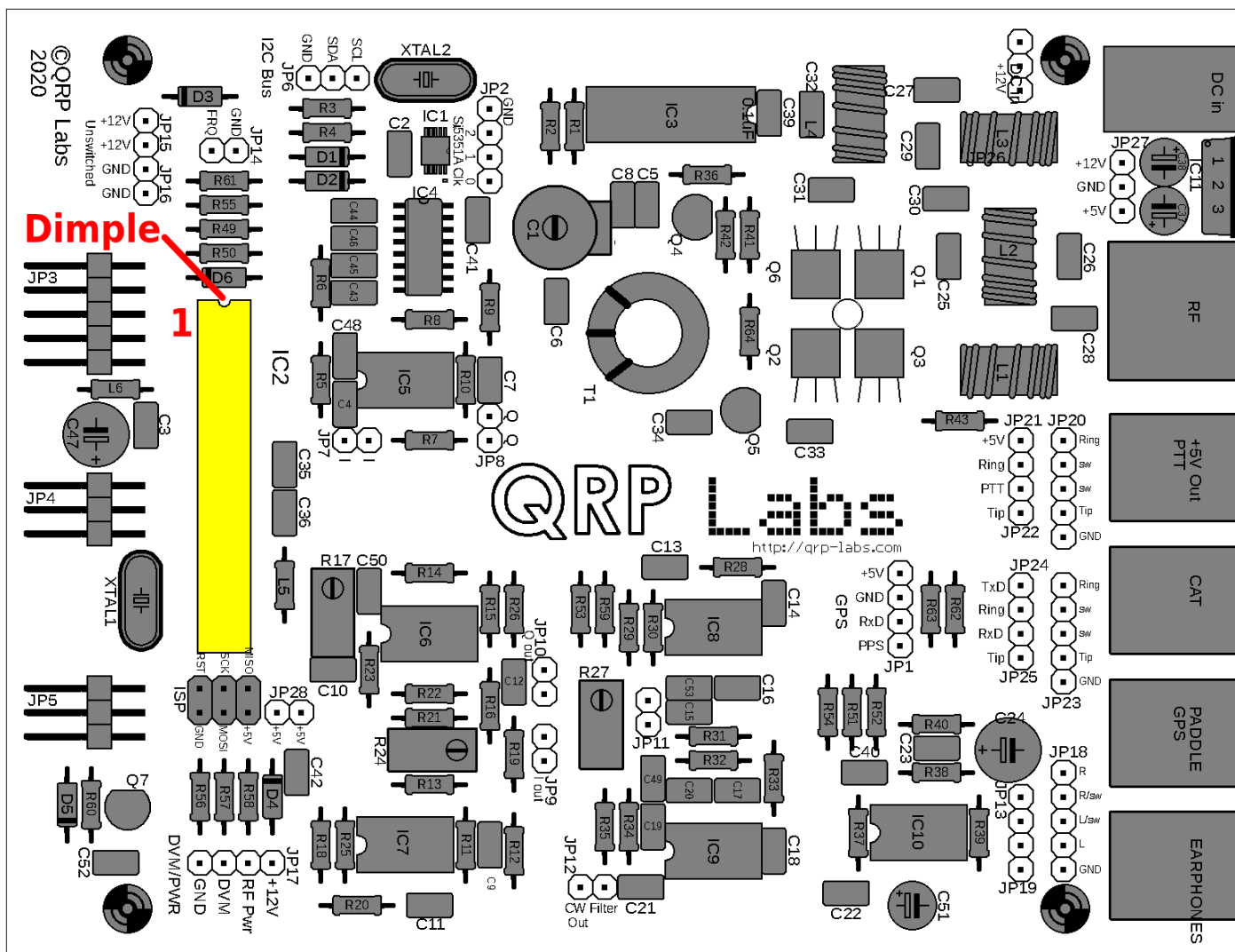

3.71 Plug together the two boards

Finally, carefully plug together the two circuit boards. Construction is now complete!

If installing the assembly in the optional enclosure, it is easiest to mount the front panel PCB to the actual front panel, BEFORE plugging the board into the main QCX+ PCB.

3.72 Installation in optional Enclosure

The QCX+ PCBs are designed to fit perfectly in the optional QRP Labs QCX+ aluminium enclosure.

Installation is extremely easy and will be mostly intuitive.

1. First bolt the front panel to the LCD module. This is the only tricky part of the enclosure assembly. Each of the four corners of the LCD module is bolted to the front panel using a 20mm black screw as shown in the diagram to the right. This is a quite fiddly operation particularly in the case of the screw next to the rotary encoder. However it is important from a mechanical perspective, to assemble this accurately and completely. *This job would be made easier if the threads of the 7mm nylon spacer are drilled out, and the threads of the M3 nuts between the LCD module and front panel PCB; leading only the final nut on the screw with its threads intact to fasten the assembly.*

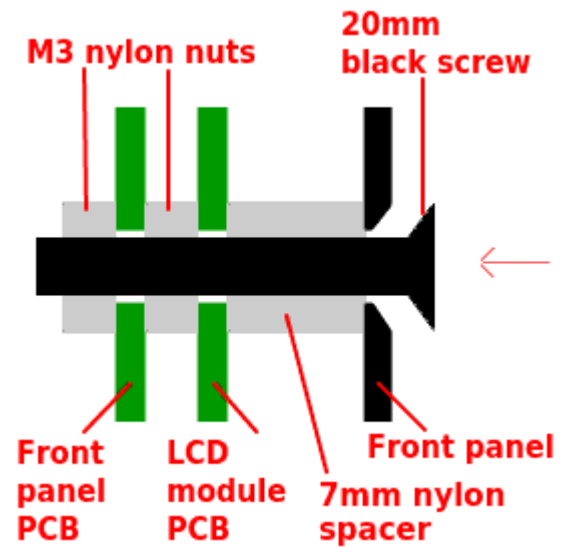

2. Now slide the main QCX+ horizontal PCB into the grooves in one half of the extruded aluminium enclosure (which will become the bottom half). If the outermost joint of the 2.1mm DC connector collides with the enclosure groove, it can be filed down.
3. Remove the washer and nut from the BNC connector, and slide the QCX+ rear panel connectors into their corresponding holes in the rear panel, then screw on the washer and nut of the BNC connector, and tighten (carefully so as to not scratch the rear panel).
4. Bolt the rear panel to the lower half of the extrusion using two of the eight supplied screws.
5. Plug the two PCBs together and bolt the front panel to the lower half of the extrusion using two of the eight supplied screws
6. Stick on the four self-adhesive feet in appropriate locations in the corners of the base of the lower half of the extrusion
7. When all the alignment steps are finished and the radio is working, you can fit the top half of the extrusion and fit the remaining four screws (two in the top corners of the front panel, two in the top corners of the rear panel). Note that the top and bottom half extrusions are identical; one side has a U-groove and the other a I-tongue. These will only fit together properly one way around, when the U-I sections match. If it doesn't fit together neatly, you need to rotate the top half 180-degrees and try again.

3.73 Connections for basic operation

The following connections are required for basic transceiver operation:

1) Power supply

A power supply is required, which needs to be able to supply up to 0.5A or a bit more, on transmit. The supply voltage may be from 7 to 16V, and the RF power output will depend on the supply voltage (higher output power is produced at higher supply voltages). Operation much above 5W output is not recommended and could lead to overheating and destruction of the final amplifier. In most cases 13.8V is sufficient and 16V produces way too much power output.

Note that the 7805 voltage regulator requires no heatsink; however the heat production will increase as supply voltage is increased, and the IC does get uncomfortably hot to touch at 16V supply. If you have purchased the optional aluminium enclosure kit, the 7805 metal tab is bolted to the rear panel of the enclosure, as a heatsink. Alternatively if you are not using the official

enclosure, and you are disturbed or worried by the high temperature, then you may fit a small heatsink to the 7805 voltage regulator if you intend to operate at higher supply voltages.

A 2.1mm DC connector plug is required; the center pin is + and the barrel is ground (negative).

2) Earphones

The earphones can be any stereo earphones such as commonly used with audio equipment, mobile phones and so on, with a 3.5mm stereo jack plug. These commonly have a 32-ohm impedance. Some people have noted unstable audio operation when low impedances are connected such as 4 or 8-ohm speakers; this is because the output op-amp IC (IC10) is not able to supply the required power output.

3) Antenna system

The RF output is a filtered 50-ohm BNC output for connection to a usual antenna system (antenna, and matching unit if applicable).

4) Straight key or paddle

To operate the QCX+ transceiver a straight key or paddle should be connected to the appropriate jack, having a 3.5mm stereo jack plug. The shield (or main body) is ground. It does not really matter which way around the tip and ring connections are (to dit or dah of the paddle) since if they are the wrong way, there is a menu configuration item to swap them around. Similarly if using a straight key, you can select in the firmware either tip, ring or both for the connection; this allows use of a 3.5mm mono plug when using a straight key.

3.74 Adjustment and alignment

The first thing that you will notice when you apply power to the radio (and after you have pressed the on/off button to switch it on!), is that there is probably nothing at all shown on the display. This is because you need to adjust the contrast trimmer potentiometer R47 at the top left of the front panel PCB on the rear side! Adjust it with a screwdriver until the display text looks right to you.

You should now see the following text on the display:



Turn the rotary encoder knob to select the band you have built the kit for. Then press the middle button to make your selection.

There are four more adjustments which now need to be made as part of the alignment procedure. The adjustments are:

- Band-pass trimmer capacitor peaking, C1
- I-Q amplitude balance, R27
- Audio phase shift adjustments, R17 and R24

Until these are adjusted, the sensitivity of the radio will be very low. So, do this first, before going any further!

The location of these four adjustments is indicated on the following diagram.

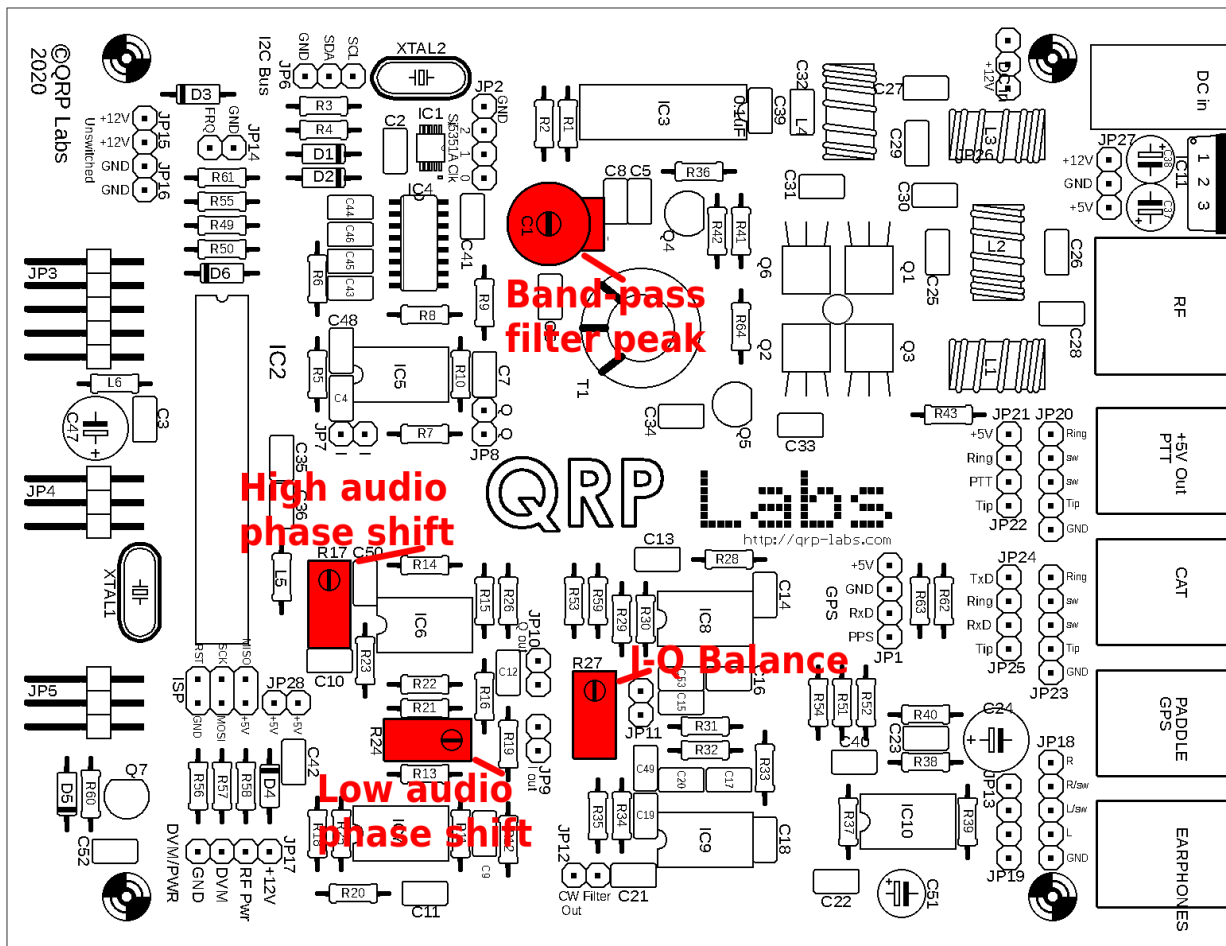

In summary: the alignment tools built into the radio consist of a signal generator which injects a signal into the RF front end, and digital signal processing which adds a 250-Hz digital filter to the existing 200Hz analogue filter, and calculates the amplitude of the signal detected in that bandwidth. During alignment, the amplitude is displayed on-screen as an intuitive bar across the bottom row of the display. Using a screwdriver, you adjust the trimmer component in order to maximise or minimise the displayed amplitude.

Unplug the antenna during alignment of the radio! Connect a 50-ohm dummy load such as the QRP Labs dummy load kit <http://qrp-labs.com/dummy>

When using the TCXO module option, change menu item 8.5 Ref frq to 25,000,000. It is critical to this before any further alignment. Enter the menu system as described below, and turn to menu 8.5, edit it to 25,000,000.

If you have installed the AGC module, please switch it off (menu 7.12) or turn AGC sensitivity fully clockwise (lowest sensitivity) before making the alignments.

First adjust the band-pass trimmer capacitor C1. To do this, give one long press to the "Select" button. Refer to the diagram (right) for naming of the buttons. The screen now displays the first menu category:

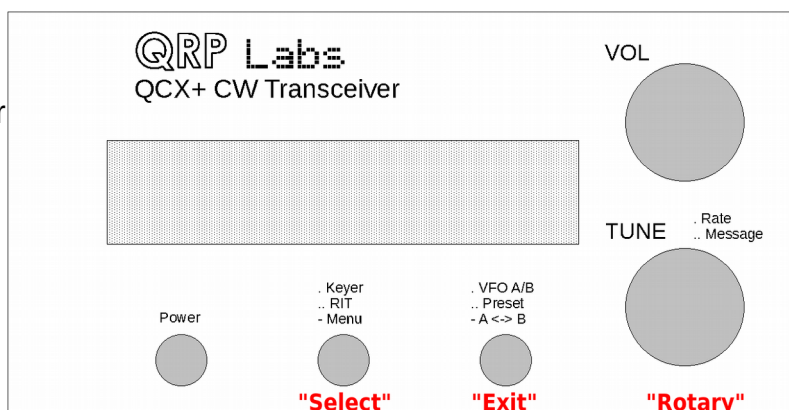

Turn the rotary encoder until you see the alignment menu:

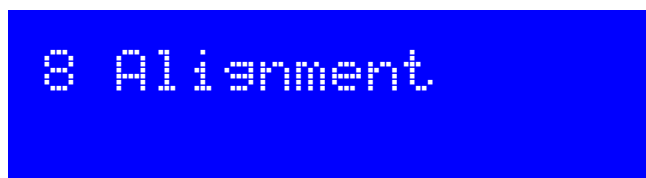

Now press the “Select” button, to enter the alignment menu. For example, for 17m operation, the alignment frequency menu item should already be set to a frequency in the CW section of 17m, as follows:

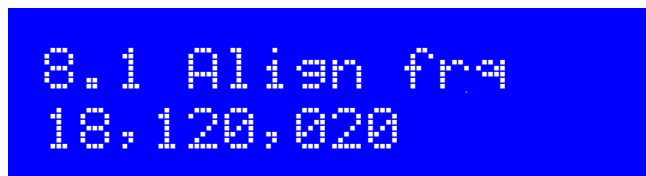

Now turn the rotary encoder until you see:



Do as it says! **But if you have earphones plugged in, please take them out of your ears first.** The tone will be very loud. Press the “Select” button to switch on the signal generator so you can adjust the C1 trimmer potentiometer. Now if you have earphones plugged in (and lying hopefully, on your bench), you will hear a loud tone at 700Hz. The display will look like this photograph:



Adjustment of the C1 trimmer capacitor should change the size of the amplitude bar. You need to adjust the C1 trimmer for MAXIMUM amplitude. There will be TWO peaks per rotation, since the capacitor has no stops; either peak is fine. When this is done, the peak of the band pass filter will be centred on the CW section of the band.

It is very important to understand the number at the top right of the LCD, here shown as 09. This is an amplitude scaling factor, expressed as a power of 2. In this example, the actual amplitude is divided by a factor of 512 (2 to the power of 9) then displayed on the screen. In this photograph, 27 little vertical bars are shown, which means the actual measured amplitude value is 13,824.

If the displayed bar drops below one third of the width of the LCD, then the division factor is reduced by one and the bar is re-displayed. On the other hand, if the displayed bar overflows the right edge of the screen, the division factor is increased by one. This simple method creates an auto-scaling display of the amplitude.

Therefore, to peak the band pass filter trimmer, first adjust the trimmer capacitor while looking at the division factor in the top right of the LCD. Then carry out the fine adjustment using the displayed amplitude bar. The peak is quite sharp.

Be wary because there can be more than one peak (more than one response of this simple band pass filter). So, tune the trimmer capacitor through its whole range, and determine the maximum scaling factor that you see. In my case here, it is 09. You may see 07, 08 etc, no problem. Then make the very fine adjustment necessary to peak the amplitude bar.

When you have peaked the response, check carefully that the C1 trimmer capacitor is not at either end of its range. If it is, this means the resonant circuit is NOT correctly peaked. You need to adjust the number of turns on the long secondary winding of the T1 transformer. Visual inspection will show clearly whether or not the trimmer capacitor is at the end of its range.



Perfect!

OK! The “solder blob” on the top plate is somewhere between the 4 o’clock and 8 o’clock position. The plates of the trimmer capacitor are somewhere nicely in their range, not at the minimum or maximum capacitance. You have found the peak response of the BPF and all is well.



Plates completely closed

Here the fixed and movable sets of capacitor plates are completely meshed, resulting in the highest capacitance. The “blob” is to the right. It means MORE inductance is needed. So carefully unsolder one end of the secondary 3 winding of T1, join a piece of wire, and wind it 5 more turns through the toroid. Then try again. Don’t worry if it looks a bit messy.



Plates completely open

Here the fixed and movable sets of capacitor plates are completely unmeshed, resulting in the lowest capacitance. The “blob” is to the left at the 9 o’clock position. It means LESS inductance is needed. So carefully unsolder one end of the secondary 3 winding of T1, remove 5 more turns through the toroid, and resolder. Then try again.

Adjustment of I-Q balance

Now turn the rotary encoder “one click” clockwise to measure I-Q balance.

Note that the previous alignment used the audio signal BEFORE the final amplification stage, so the gain control had no effect on the signal level. In contrast, the I-Q balance and audio phase shift adjustments use the audio signal AFTER the audio amplification stage. This is necessary because these alignment adjustments inject a signal into the opposite (unwanted) sideband, and the signal level is much lower, therefore it needs to be amplified for the microcontroller to be able to measure it accurately. In this case therefore, the gain control DOES now have an effect. I suggest adjusting the gain control approximately to mid-way to start with. This will provide enough gain, yet not so much gain that the amplifiers are driven into overload, which distorts the signal and measurements.

You should try to carry out the adjustments with the measured audio values in the range 5 to 10 (as indicated by the division ratio in the top right of the display). If it reaches 12, the operational amplifiers are limiting, clipping the signal which will make it difficult or impossible to make the

adjustment accurately. If the displayed value (top right of the display) is only 2 or 3, that indicates the gain is too low. Therefore, adjust the volume control so that the display is something like 9.

The I-Q trimmer potentiometer is R27. It is a multi-turn trimmer potentiometer so it may need to be turned quite a few times to get to the optimum value! For this adjustment, you are looking for the MINIMUM amplitude, not the maximum we adjusted the BPF trimmer to. We adjust for minimum because now the injected signal is measuring the unwanted sideband. We want to MINIMISE the unwanted sideband level.

Adjustment of 90-degrees audio phase shift

Similarly turn the rotary encoder one more “click” clockwise, which automatically sets the unwanted sideband audio signal to appear at 600Hz, and adjust the “low audio phase shift” trimmer potentiometer, R24. Again, adjust it for MINIMUM signal.

Turn the rotary encoder clockwise one more “click” and adjust the “high audio phase shift” trimmer potentiometer R17, again for minimum signal.

Now it is necessary to go back and forth between these three menu items for minimum unwanted sideband:

- 8.8 I-Q Bal (adjust R27)
- 8.9 Phase Lo (adjust R24)
- 8.10 Phase Hi (adjust R17)

This is because to some extent, these adjustments influence each other. Obtaining the optimum set of adjustments is an iterative process. So, turn the rotary encoder a click at a time anti-clockwise or clockwise, back and forth through these three menu items. Each time make small further adjustments to the appropriate trimmer potentiometer and observe the lower amplitude. Keep doing this until you see that you cannot really manage to get the unwanted sideband any lower in any of those adjustments. Pressing the “Exit” button twice leaves the menu system and returns the radio to normal operation.

Other items in the alignment menu relate to the calibration of the 27MHz reference oscillator of the synthesiser, and the 20MHz system clock oscillator of the microcontroller. These adjustments can be made manually, or by connection of a GPS module such as the QRP Labs QLGx-series GPS receiver kits. However, since this calibration is a lot less urgent than the Band Pass Filter peaking and unwanted sideband cancellation, they are left until the description of these menu items in the operating manual.

Following the adjustment of these alignment trimmers, the radio is ready to use. A lot of settings are available in the configuration menu, and you should read the operation manual to understand and make use of all the features!

3.75 Experiments, modifications and the QCX+ Dev kit

The QCX+ is designed for easy experiment and modification. The PCB layout is quite low density and there are an abundance of pin header connection points.

The QCX+ Dev kit can be installed above the main QCX+ PCB, and has matching sets of pads. It is supplied with suitable pin header plugs and sockets so that you can make connections to these points between the boards. If you wish, in certain places you can cut tracks on the main QCX+ PCB to route signals through to the Dev board instead.

For example, at the I and Q outputs of IC5, there are two pads, which are connected by a PCB trace. You could connect a pin header here to make a connection to the Dev board. If you wanted to interrupt the signal path you could cut the track between the two pads.

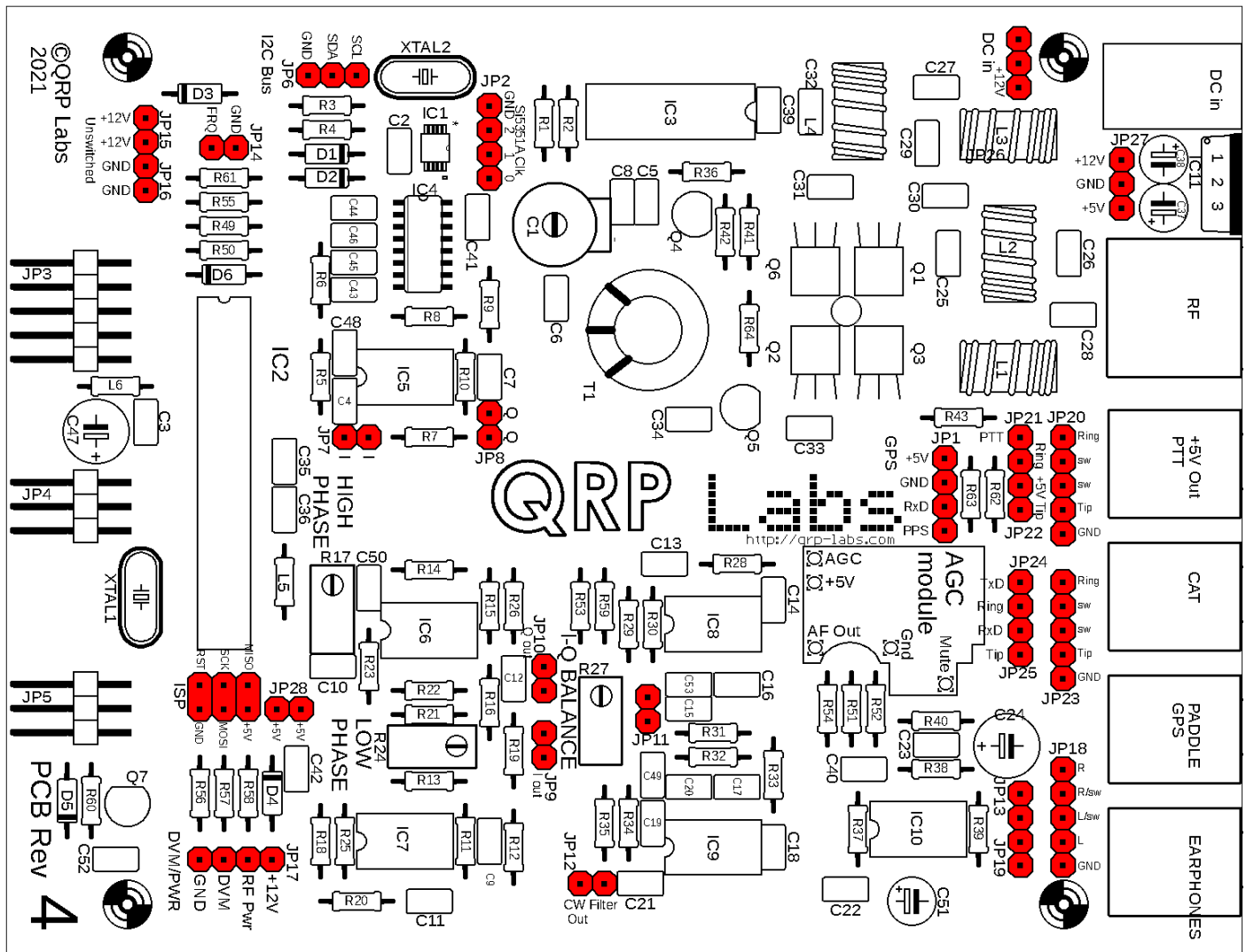

The complete list of pin header pads and their function is as follows:

- JP1 GPS interface, 4-pin header with +5V, GND, RxD and PPS signals identified on the PCB silkscreen in the usual pinout of QRP Labs GPS connectors.
- JP2 Si5351A outputs, a 4-pin header with GND, 2, 1 and 0 indicated on the PCB silkscreen. Take care not to overload and damage the Si5351A because it's a devil to replace that tiny IC (don't ask me how I know).

- JP3 2x5-pin connector to the front panel PCB (power, buttons and LCD control signals)
- JP4 2x3-pin connector to the front panel PCB (rotary encoder signals and LCD data lines)
- JP5 2x3-pin connector to the front panel PCB (audio volume control only)
- JP6 I2C bus, 3-pin header with SCL, SDA and GND indicated on the PCB silkscreen
- JP7 I-channel pre-amplifier output of IC5
- JP8 Q-channel pre-amplifier output of IC5
- JP9 Phase-shifted output of the I-channel path, at IC7A pin 1
- JP10 Phase-shifted output of the Q-channel path, at IC6A pin 1
- JP11 Input to the CW filter (and wiper of R27, the I-Q balance summation trimmer potentiometer)
- JP12 CW filter output
- JP13 2-way header with audio output signal and ring of the 3.5mm stereo jack Earphones socket; this can be used to reconfigure how and which signals are connected to the 3.5mm stereo jack socket (with JP18 & JP19)
- JP14 Frequency counter test equipment input (GND and FRQ signals are marked on the PCB silkscreen)
- JP15 Polarity-protected +12V, but before routing to the On/Off switch on the front panel; the trace between the two pads of JP15 could be cut if you want to provide your own switching or power solutions on the Dev board.
- JP16 Two ground-pins
- JP17 DVM/PWR 4-way header, providing access to the DVM and RF Pwr test equipment, with signal labelling on the PCB; the header also provides +12V which could be jumpered to the DVM input if you wish to use the onscreen battery icon to show battery voltage. Note that the RF Pwr and DVM test instruments cannot both be used at the same time
- JP18 Earphones 5-way pin header, that provides access to all five connections of the 3.5mm stereo jack Earphone socket (with JP13 & JP19)
- JP19 2-way header with audio output signal and tip of the 3.5mm stereo jack Earphones socket; this can be used to reconfigure how and which signals are connected to the 3.5mm stereo jack socket (with JP13 & JP18)
- JP20 PTT/+5V Out 5-way pin header, that provides access to all five connections of the 3.5mm stereo jack +5V/PTT socket (with JP21 & JP22)
- JP21 2-way header with +5V; this can be used to reconfigure how and which signals are connected to the 3.5mm stereo jack socket (with JP21 & JP23)
- JP22 2-way header the PTT output signal; this can be used to reconfigure how and which signals are connected to the 3.5mm stereo jack socket (with JP20 & JP21)
- JP23 CAT 5-way pin header, that provides access to all five connections of the 3.5mm stereo jack CAT socket (with JP24 & JP25)
- JP24 2-way header with CAT port TxD signal; this can be used to reconfigure how and which signals are connected to the 3.5mm stereo jack socket (with JP23 & JP25)

- JP25 2-way header with CAT port RxD signal; this can be used to reconfigure how and which signals are connected to the 3.5mm stereo jack socket (with JP23 & JP24)
- JP26 Input power, 3-way pin header providing Gnd and the +12V raw connection to the 2.1mm power connector, un-switched and un-polarity protected. Two of the pins are +12V and have a thin trace between them which can be cut if you wish to arrange for power switching on the Dev board for example
- JP27 Switched, polarity protected 3-way pin header power connector providing access to +12V, GND and +5V as indicated by the PCB silkscreen lettering
- JP28 2-pads providing +5V power to the 2x3-pin ISP header; they could be used to provide +5V power to the Dev board or you could cut the trace between them if you wish to interrupt power to the 2x3-pin ISP connector, if your AVR programmer is not a type that needs it
- ISP The 2x3-pin ISP header. A matching socket on the Dev board, could be used to connect to this and then another 2x3-pin ISP header; that Dev board would not need to be removed in order to access the 2x3-pin ISP header for chip re-programming (firmware update)

In many parts of the circuit diagram (schematic) you will see this strange symbol with two circles and a line through it, such as labelled JP24 and JP25 in the diagram here (right). These are 2-pin header pads, with a trace connecting the two pins. You can use these pins for an inter-board connection to the QCX+ Dev board. Or if you wish to alter the signal flow in some parts of the circuit, you could cut the trace between the two pads.

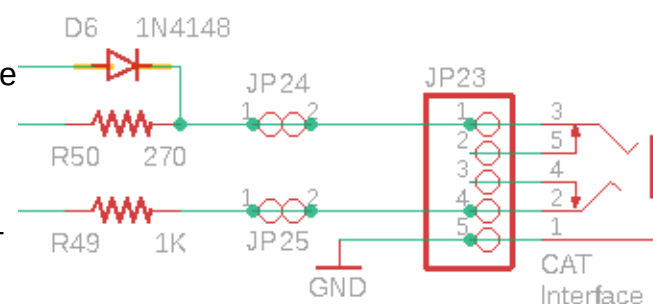

The QCX+ Dev board layout is shown in the diagram below.

This QCX+ Dev board is supplied with the following accessories in addition to the 120 x 95mm PCB:

- 4pcs 12mm nylon hex spacer for mounting the PCB above the main QCX+ PCB
- 8pcs 6mm nylon screw, to bolt the 12mm hex spacers in position
- 8pcs 2-way female header connectors
- 1ps 20-way male header connector (may be broken into smaller pieces as desired)

The QCX+ Dev board is designed to be bolted in place above the QCX+ main PCB, using the 12mm nylon spacers. The perimeter cut-out near the top right of the PCB (in the following diagram) is to prevent clashing with the tab of the 7805 voltage regulator on the QCX+ PCB. The ring of pads around the outside of the PCB are intended to be grounded. You need to decide which connections to bring from the main QCX+ PCB to the Dev PCB, using pin header connectors. The pads on the Dev board line up exactly with the corresponding pads on the main QCX+ PCB.

Additionally, the QCX+ Dev board has holes drilled to allow access to the C1 band pass filter capacitor, and the three receiver adjustment trimmer potentiometers.

The rest of the QCX+ Dev board is covered in a 0.1-inch spaced matrix of through-hole plated holes, each having a pad on either side of the PCB.

simple audio amplifier with a small loudspeaker. Installing two pins (one for audio, one for ground) and a corresponding socket on the underside of the QCX+ Dev board, would allow you to carry audio to the input of your audio amplifier from the tip “switch” pin of the 3.5mm socket, only when no earphones are plugged into the socket. In this way, you can arrange for your internal loudspeaker to automatically be used only when no earphones are plugged in.

GPS interface

The QCX+ has a GPS interface which can be used to:

- Calibrate the reference oscillator (27MHz crystal or 25MHz TCXO module option) and the 20MHz system oscillator
- Keep the oscillators disciplined and drift-free (frequency and time) during WSPR beacon operation
- Set the internal Real Time Clock, which is critical for WSPR options and may be displayed on-screen if you have configured it.

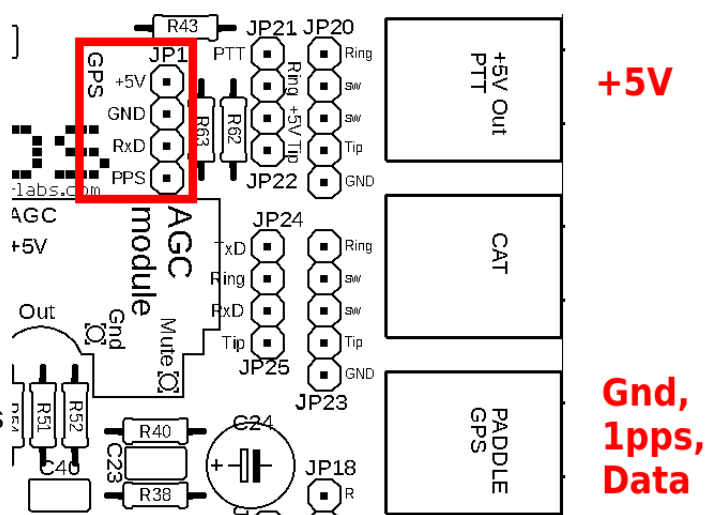

The GPS produces two output signals, PPS (Pulse-per-second) and RxD (Serial data), in addition to ground. Optionally +5V may also be connected, in order to power the GPS module. A GPS such as the QRP Labs QLG1, QLG2 or QLG2-SE is perfect for this see <http://qrp-labs.com/qlg2se>

There are two places to connect the GPS. The first is the 4-pin header in the above diagram fragment, enclosed in the red rectangle. The ordering of the four pins matches the corresponding port of the QLGx GPS. Remember that the “TxD” serial data **output** signal of the QLGx GPS is connected to the “RxD” serial data **input** signal on the QCX+.

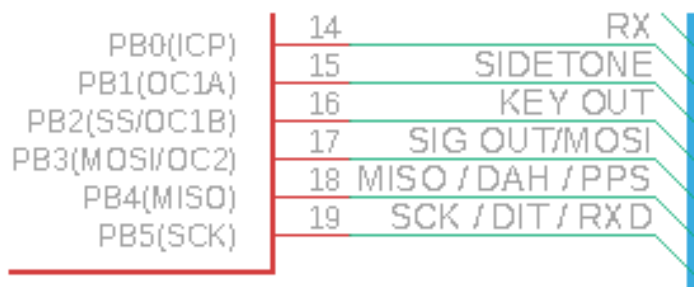
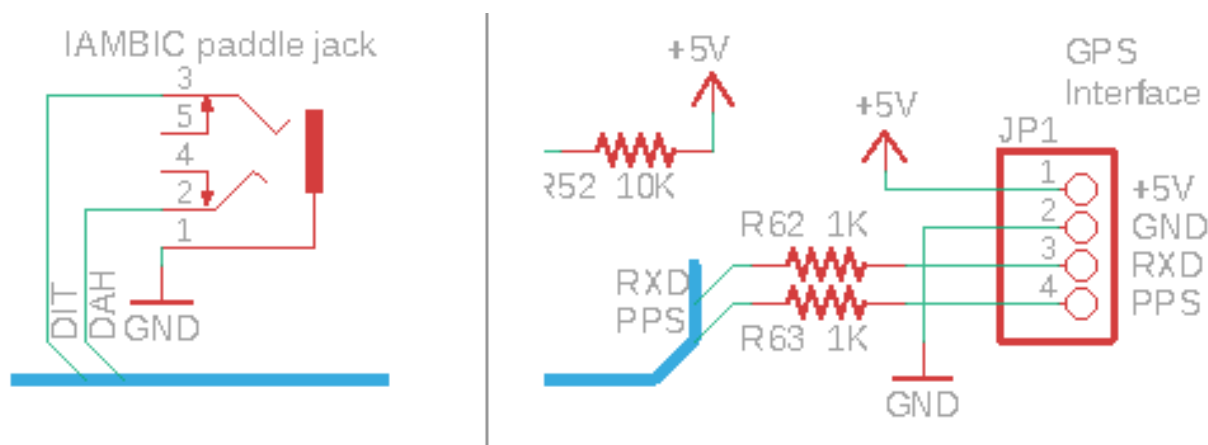

Secondly, consider the three different sections of the circuit diagram, shown above. It will be apparent that the paddle “Dit” signal is connected to pin 19 of the microcontroller, which is also the

GPS “RxD” connection via a 1K resistor. Similarly the paddle “Dah” signal is connected to the GPS interface “PPS” signal via a 1K resistor. The purpose of the resistor is only to prevent shorting GPS signals to Ground if the operator accidentally squeezes the paddle while the GPS is connected.

Therefore a convenient alternative way to connect the GPS is just via the Paddle connector. A second 3.5mm stereo jack can be plugged into the +5V/PTT jack to provide +5V power to the QLGx GPS if needed (i.e. if you are not connecting to a shack GPS which is already powered). You will not be using a paddle and GPS at the same time in any case.

The following diagram shows the connections.

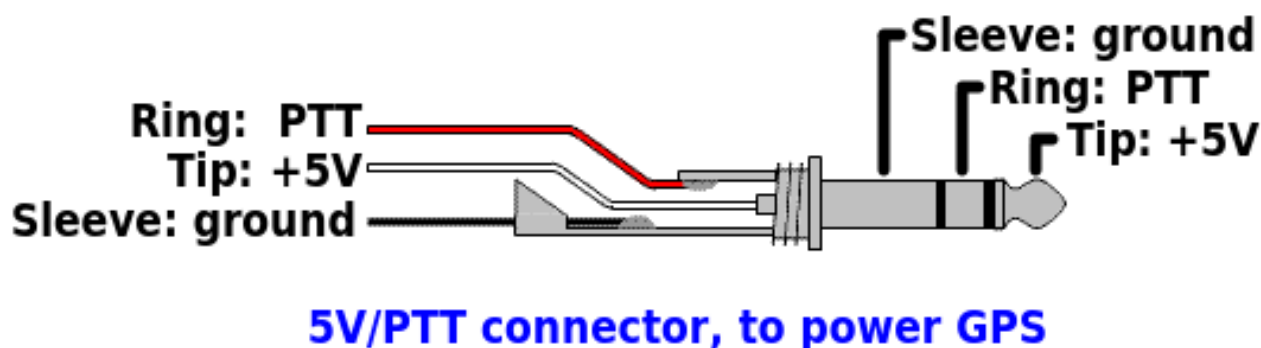
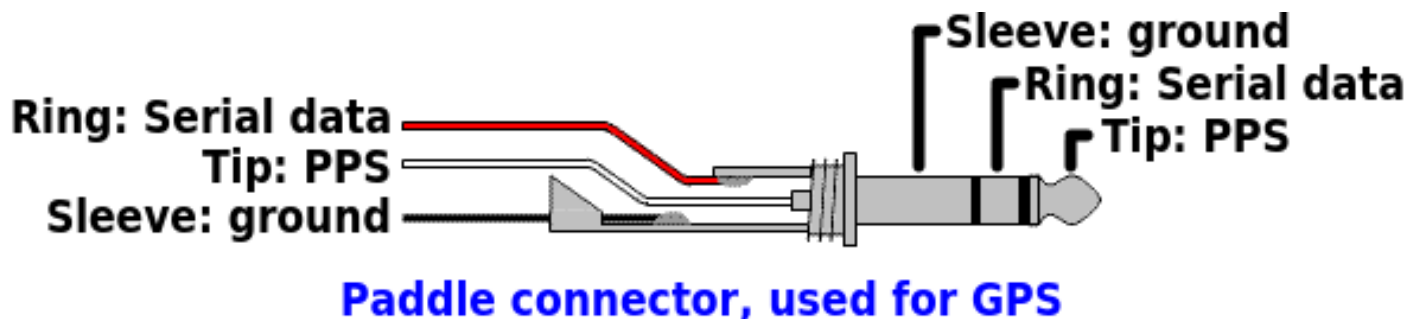

PTT output

The PTT output is at the ring of the 5V/PTT connector jack. This signal is 0V when the QCX+ is in Receive mode, and +5V when the QCX+ is in Transmit mode. If you are connecting the QCX+ to the companion 50W PA kit, then this signal has to be connected to the 50W PA kit to cause it to switch to Transmit mode.

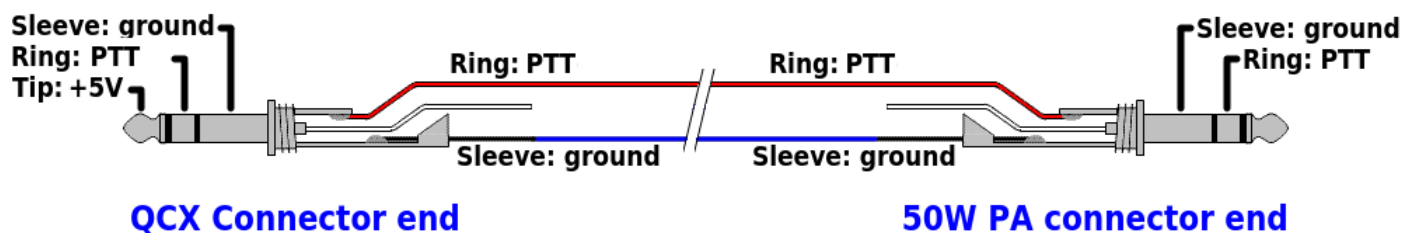

A standard 3.5mm stereo audio extender cable can be used for this connection; these are common and inexpensive.

NOTE: Earlier QCX+ PCB revisions had the Ring and Tip connections swapped; if you are using an earlier QCX+ PCB revision please refer to the correct manual for that kit.

3.77 QCX+ CAT port

The QCX+ CAT port allows a PC or other CAT-enabled host to control every aspect of the QCX+. Operation of this feature is detailed in a subsequent chapter of this manual. The connection diagram below shows the connections to the 3.5mm stereo jack socket connector on the rear panel of the QCX+.

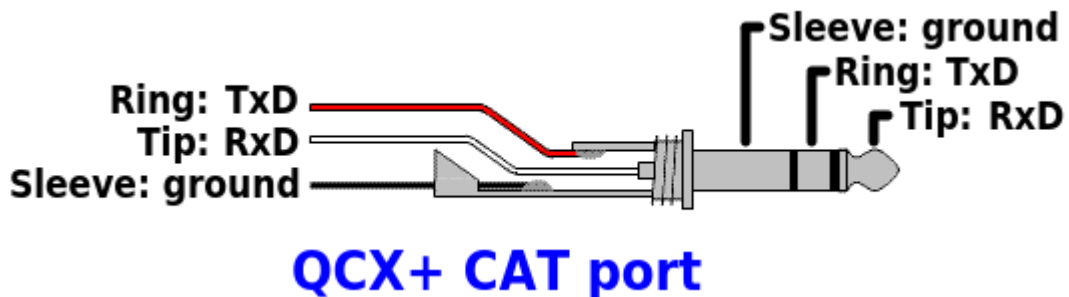

4. Operating instructions

From firmware 1.06 onwards, operating instructions are now in their own separate document, which is maintained per firmware version. So please visit <http://qrp-labs.com/qcxp/qcxpfirmware.html> and download the operating manual appropriate to your firmware version.

5. Circuit design of the QCX+

5.1 Block diagram and summary

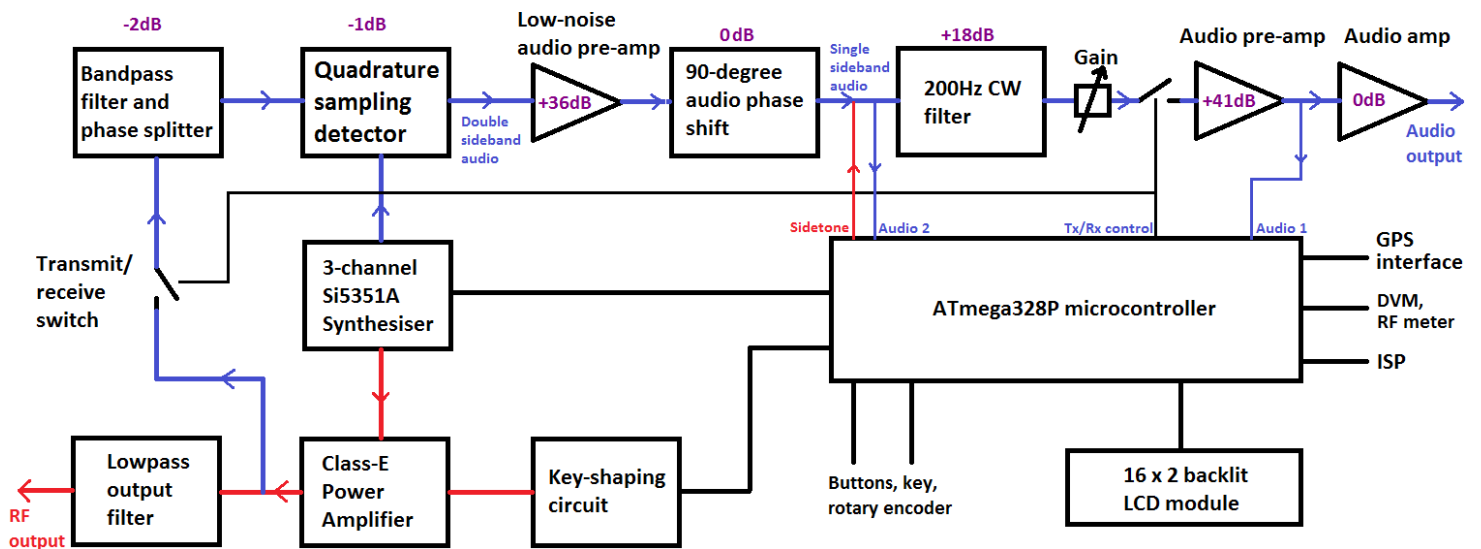

This CW transceiver is a high performance, yet simple and low cost, analogue design. The transmitter uses a high efficiency Class-E amplifier which results in low current draw on transmit, and inexpensive transistors with no heatsinks.

The receiver is a direct conversion type utilising the famous high performance Quadrature Sampling Detector, also known sometimes as the “Tayloe Detector” or even “I-Q Mixer”. This receiver front end architecture has been used in the early Flex Software Defined Radios, Softrock series, Norcal NC2030 and many other SDR's and other high performance front ends. The detector has very high third order intercept (IP3) and dynamic range, as well as low loss.

The resulting I & Q outputs are at audio baseband and go through a 90-degree phase shift network which cancels the unwanted sideband. A 200Hz bandwidth CW filter is followed by more amplification and drives common earphones.

The oscillators in the transceiver are provided by the modern Si5351A digital phase locked loop IC controlled by the microcontroller.

Permeating the entire design is microprocessor control by the ATmega328P microcontroller. This allows implementation of a large number of functions normally only found in radios costing 10-100x the price!

A really nice feature of the design is the built-in alignment and test equipment, which make it possible to build, align and even debug the assembly of the radio, all with NO additional test equipment.

5.2 Circuit diagram

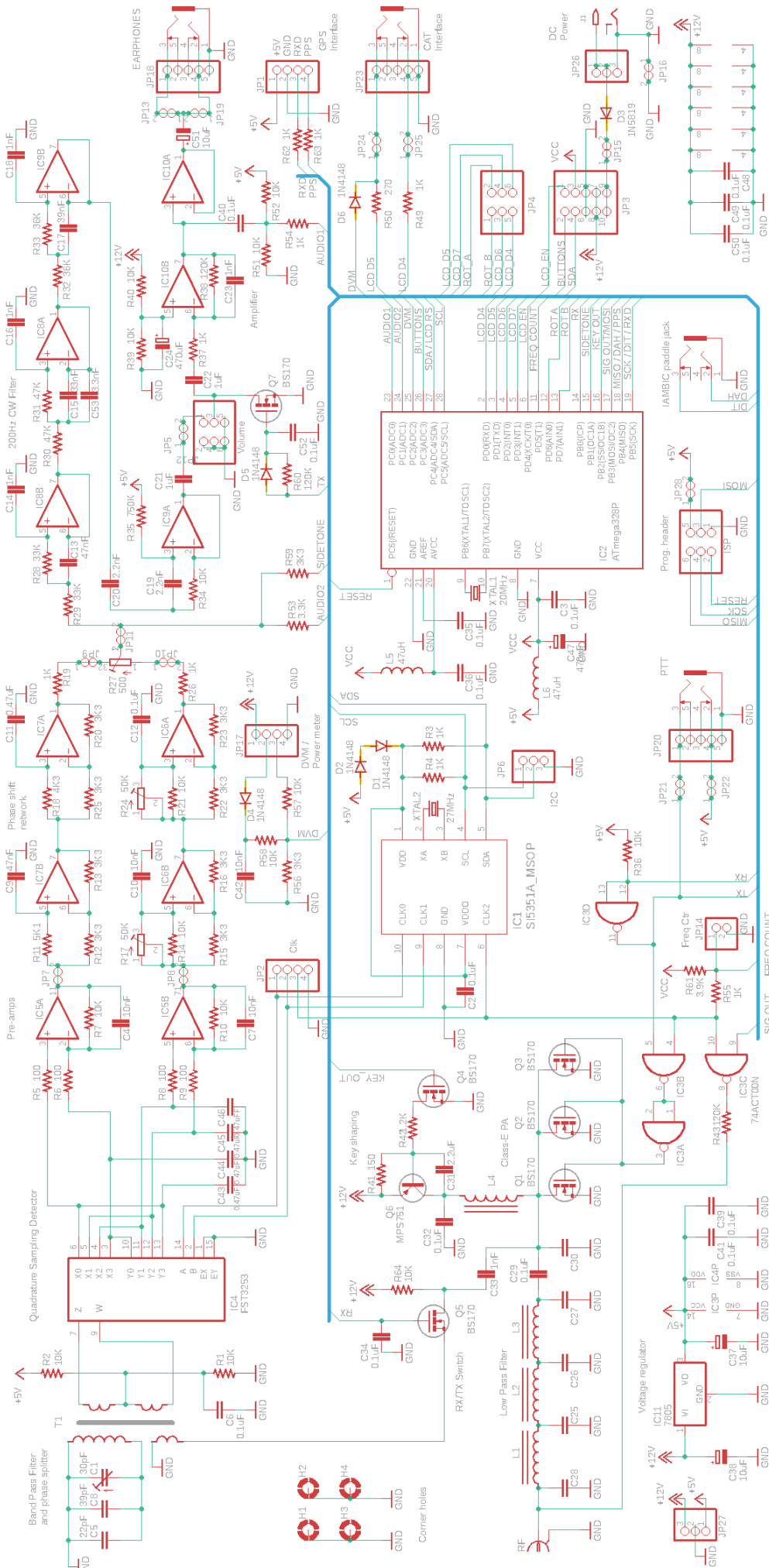

The circuit diagram (schematic) of the main PCB is shown on the previous page. The circuit diagram of the front panel PCB is shown below. Three 2-row connectors with right-angled pins on the main PCB connect the two boards; one has 2x5-pins and the other two, 2x3-pins each.

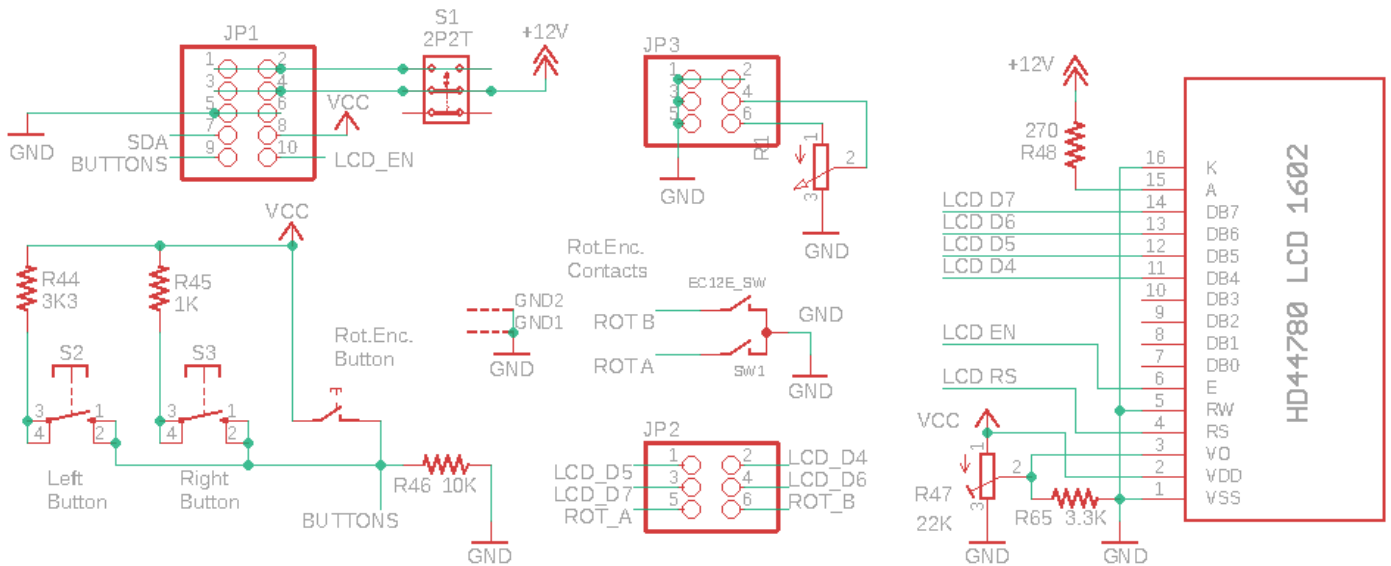

5.3 Synthesised oscillator

I always start with building the VFO of a radio. It was the hardest thing to get right. How to get that analogue LC-tuned VFO accurate, free of drift, free of chirp, tuning over the required range, and with mechanical gearing to be able to make fine frequency adjustments? A real challenge. Not anymore! Now we have Direct Digital Synthesis (DDS) ICs and Digital Phase Locked Loop (PLL) ICs, inexpensive and easy to use, that solve all the problems.

The Si5351A Synthesiser chip used in this design provides three separate frequency outputs, with a frequency range spanning 3.5kHz to 200MHz. The frequency stability is governed by the 27MHz crystal reference. Pretty stable, in other words.

The block diagram (right) is taken from the SiLabs Si5351A datasheet. Briefly, the 27MHz reference oscillator is multiplied up to an internal Voltage Controlled Oscillator in the range 600-900MHz (the PLL), then divided down to produce the final output frequency. The multiplication up and the division down are both fractional and so the frequency resolution is extremely finely controlled. The chip has two PLLs and three output divider units.

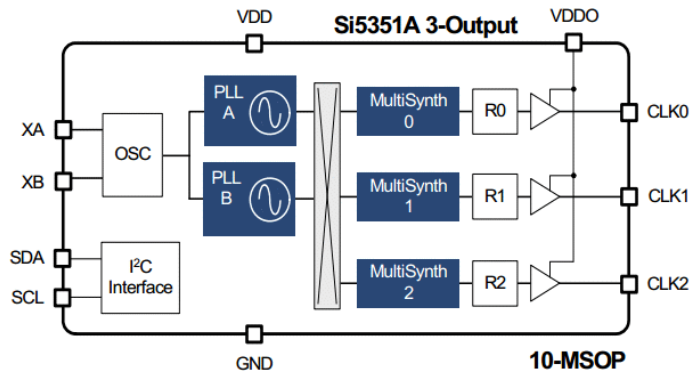

For best jitter performance, the Si5351A datasheet recommends the use of even integer dividers (no fractional component) in the MultiSynth dividers and in this CW transceiver design, this recommendation is followed.

The synthesiser section of the circuit diagram is shown here (right). The Si5351A datasheet dictates the use of a

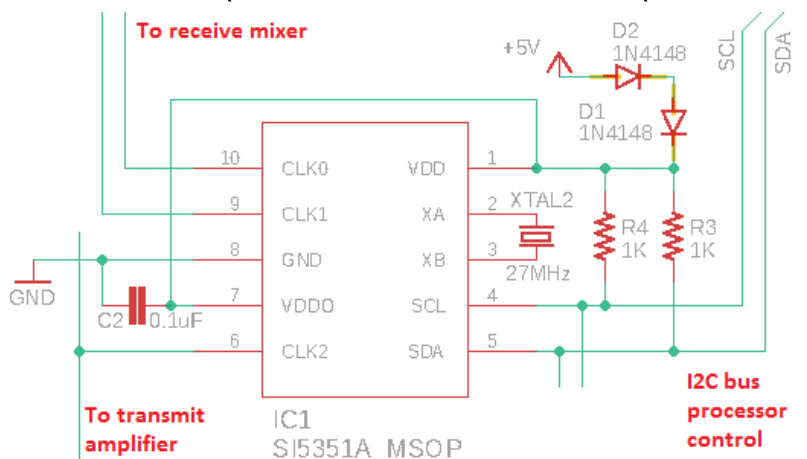

25 or 27MHz crystal. QRP Labs has always used the 27MHz crystal in our designs because it allowed us to obtain precise 1.46Hz tone spacing for WSPR transmissions all the way up to the 2m amateur band (145MHz). Those calculations don't work out with the 25MHz crystal. This requirement doesn't apply to this CW transceiver design but economics of scale means there are advantages to sticking with the same component values, all other things being equal!

The Si5351A has a large number of internal 8-bit registers to control the synthesiser behaviour, and these are programmed by the microcontroller using the I2C serial protocol. 1K resistors R3 and R4 are pull-ups required for the operation of the bus at 400kHz.

The Si5351A chip requires a 3.0 to 3.6V supply (nominally 3.3V) but the rest of this transceiver's digital circuits operate with a 5V supply. For the reduction of complexity and costs, two 1N4148 diodes in series are used here to drop the 5V to a suitable voltage for the Si5351A. It works well.

There are three outputs of the Si5351A synthesiser and these are all used to good advantage. The Clk2 output is used to feed the transmit power amplifier, and the Clk0/1 outputs are used to drive the Quadrature Sampling Detector (QSD) during receive. These outputs can be switched on and off under the command of the microcontroller. This provides an opportunity for some simplification because the Clk0/1 outputs can be simply switched off entirely during transmit. This relieves pressure on the transmit/receive switch. There just cannot be any reception during transmit because there is no oscillator input to the receive mixer. Conversely, the Clk2 output is switched off during receive.

A feature of the Quadrature Sampling Detector is that either the RF input, or the LO input, must provide two paths in 90-degree quadrature. This is normally applied at the Local Oscillator where it can be easily controlled for best performance. So, two oscillator signals are required, with the same frequencies but a precise 90-degree phase offset. Generating this quadrature Local Oscillator signal is always difficult. Analogue phase shift circuits have limited accuracy. Often a divide-by-4 circuit is used, to produce quadrature oscillator outputs from an oscillator input at 4x the reception frequency. This also creates challenges particularly as you try to increase the reception frequency to cover higher bands. For example, on 10m e.g. 30MHz, a local oscillator at 120MHz is required and the divide-by-4 circuit must be able to operate at such a high frequency. Devices such as the 74AC74 can do so, but pushing it higher into the 6m band cannot be done with the 74AC74.

The Si5351A has a phase offset feature, which is not really very clearly described in the SiLabs documentation. However, QRP Labs has perfected the technique to put two of the Si5351A outputs into precise 90-degree quadrature, which is maintained without tuning glitches as the frequency is altered. It's a nice development because it eliminates one more circuit block (the 74AC74 divide-by-4 circuit), again reducing complexity and cost. To the best of my knowledge this the first time the Si5351A has been implemented in a product directly driving a QSD with two outputs in quadrature (no divide-by-4 circuit).

The Si5351A section of the circuit also provides 4-way pin header pads providing connection points for: Clk0, Clk1, Clk2 and Ground; and a 3-way pin header pads providing connection points for the I2C bus: SCL, SDA and Ground. For clarity these are omitted from the above diagram.

5.4 Transmit/Receive switch

Since the receiver is entirely disabled during transmit, because of the absence of any local oscillator signals to the Quadrature Sampling Detector, the demands on the transmit/receive switch are considerably reduced. Now the circuit does not have to provide the massive amount of attenuation necessary to prevent the transmitter from overloading the receive circuits. All it has to do is provide a reasonable amount of attenuation, enough to stop the 5W signal (45V peak-peak) from damaging the receiver input mixer.

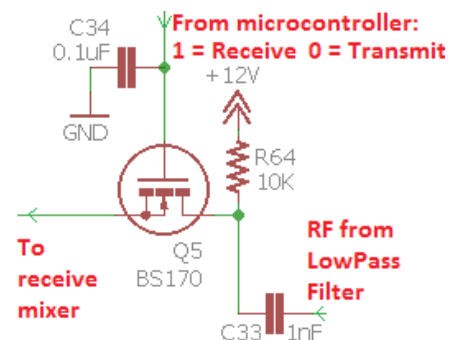

The transmit/receive switch is implemented by a single BS170 MOSFET. The source is at DC ground (via the primary of input transformer T1). The control signal from the microcontroller switches the MOSFET on or off. Interestingly, capacitor C34 close to the MOSFET gate is found to be necessary to prevent inductive pickup of the 5W RF from partially switching on the MOSFET.

The switch wouldn't provide enough attenuation to mute an operating receiver; but during transmit, our receiver isn't operating; all the switch has to do is protect the Quadrature Sampling Detector from seeing 45V peak-peak which would destroy it.

5.5 Band Pass, Phase Splitter, QSD and pre-amps

Since the band-pass filter, Phase splitter, Quadrature Sampling Detector and pre-amp circuits are so tied up together, I am going to consider them all together in this section.

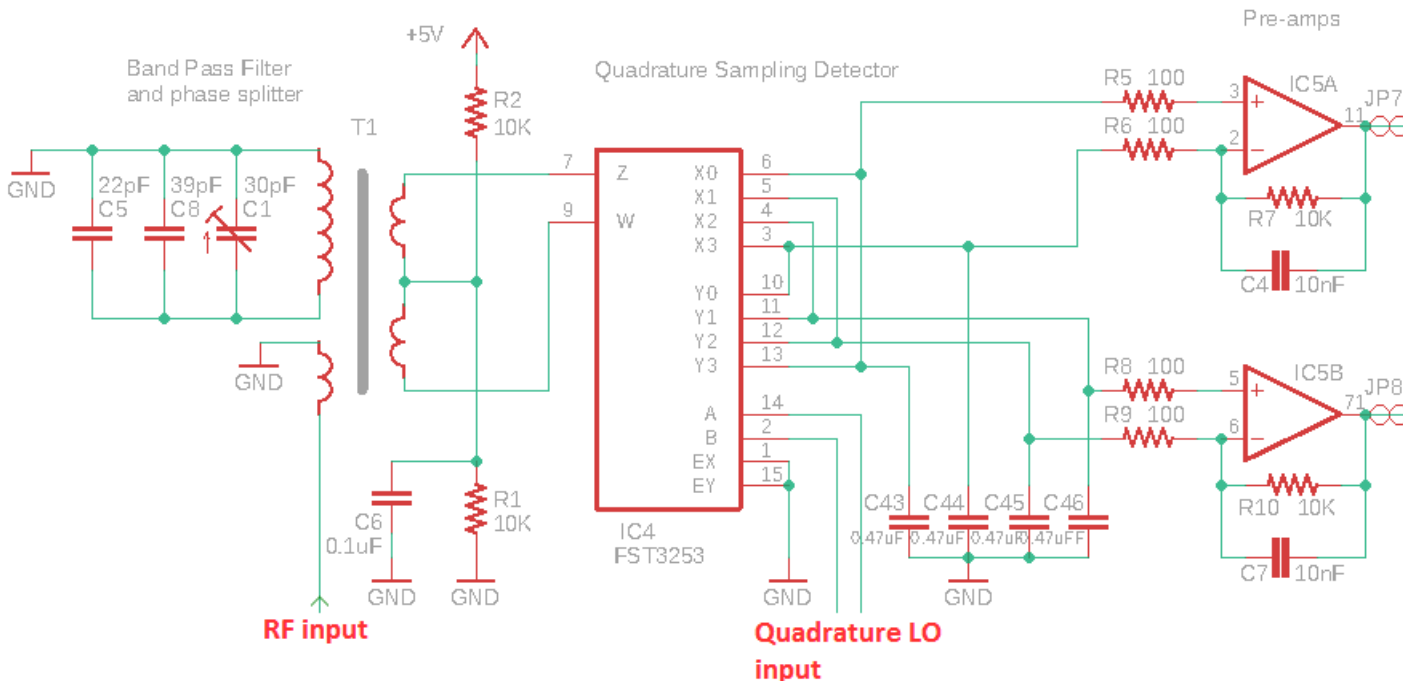

This circuit implements an input band-pass filter and double-balanced Quadrature Sampling Detector with low-noise pre-amps. Yet it does this with a low parts count, and resulting low complexity and cost. The FST3253 is a dual 1:4 multiplexer which is often seen in QSD circuits. It has fast switching times and very low on resistance of only a few ohms. The input signal is switched by the quadrature LO to each of the four integrating capacitors C43-C46 in turn, for 90-degrees of the RF cycle each. The result is that the audio difference (beat) between the RF input

and LO input appears across each of the four integrating capacitors, with four phases at 0, 90, 180 and 270 degrees.

The operational amplifier IC5a takes the difference of the 0 and 180-degree outputs and amplifies it, resulting in the I output of the QSD. Similarly, IC5b differences the 90 and 270-degree outputs to produce the Q output.

The combination of the relatively large 470nF capacitors and the low source resistance results in a fast roll-off of the audio response. This is effectively a very narrow band pass filter since any incoming RF more than a few kHz away from the LO frequency is greatly attenuated. The QSD is therefore inherently a very high performance mixer design with high third order intercept and dynamic range, and low loss (0.9dB).

The FST3253 dual switch is often connected with the two switches simply paralleled together (which does half the switch ON resistance). But I prefer the double-balanced mixer configuration which provides higher performance. The double-balanced configuration requires two RF inputs 180-degrees out of phase (opposite to each other).

Despite the high IP3 and dynamic range, it is still prudent to provide some input band pass filtering to protect the mixer from strong out of band signals. In this CW transceiver design, the T1 transformer provides a simple solution to all of these problems with a very low parts count.

The primary couples the incoming RF into the two secondary windings which feed the double-balanced detector. One end of the primary is grounded which neatly keeps the DC potential of the input at ground, so the transmit/receive switch is easily implemented by a single MOSFET (see previous section). The two secondaries are connected as a centre-tapped single winding, which means that the outputs have 180-degree phase difference as required.

The secondary “centre-tap” is connected to a DC bias formed by R1, R2 and C6 at mid-rail i.e. 2.5V. This simple bias does not source or sink any significant current due to the balanced nature of the system, therefore no buffering is required. The DC bias feeds through the pre-amps, and into later stages – including the 90-degree phase shift network and the first three op-amps of the CW filter. It is a great benefit not to have to AC couple each stage with coupling capacitors, and then bias each stage individually. In this circuit, the same DC bias flows through all the way from this centre-tapped input transformer. This reduces component count and - you guessed it – complexity and cost. Another benefit is that since much of the receiver signal path is DC coupled, it might be easier to reduce the inevitable “thumps” on switching between receive and transmit.

Finally, the band pass filter is implemented by a fourth winding on the same transformer T1, with some fixed capacitors and a trimmer capacitor forming the resonant circuit. It is only a single resonant circuit band pass filter so has limited stop-band attenuation, but it does have the benefit of low parts count, and simplicity of adjustment due to the single adjustment control.

Note that the I and Q outputs each have a 2-pin header pad labelled JP7 and JP8 in the diagram; these can be used to make experimental modifications or connections.

5.6 90-degree audio phase shift

By this stage the I and Q outputs are each double-sideband, and we need to process them to demodulate single sideband.

The circuit used here is an active two-path all-pass phase shift network based on four operational amplifiers. The circuit is based on the same phase shift block as the Norcal NC2030

<http://www.norcalqrp.org/nc2030.htm>

In the real world, nothing is perfect – there are component tolerances to think about. The unwanted sideband suppression is maximised when the amplitude of the two paths is equal, and the 90-degree phase shift is accurate.

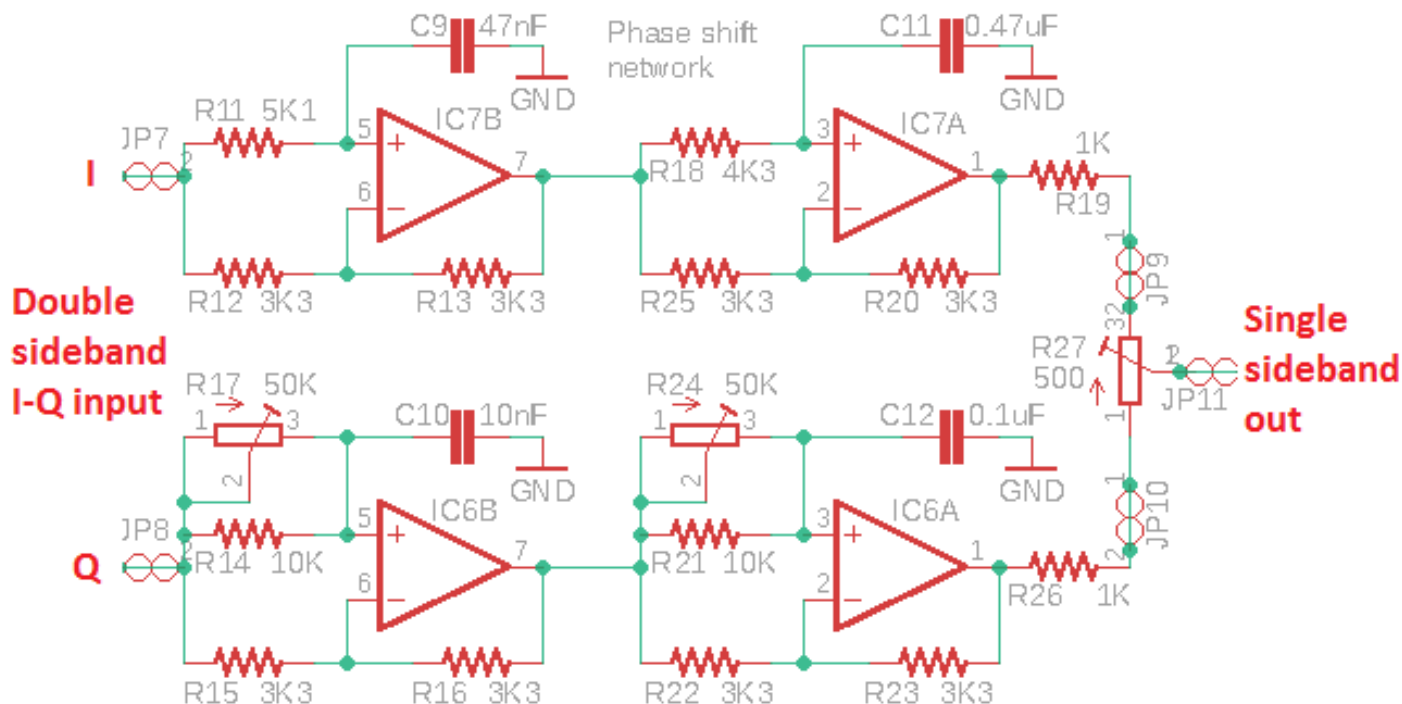

To improve the accuracy of the 90-degree phase shift, R17 and R24 allow adjustment of the phase shift at higher and lower audio frequencies respectively.

R27 allows adjustment of the balance between the I and Q channels, to equalise the amplitude from each path.

This CW transceiver kit includes built in alignment and test equipment, with a signal generator that can inject a test signal into the receiver input. It makes it easy to perform these adjustments, as described previously.

Note the 2-pin header pads JP9, JP10 and JP11 at the output combination potentiometer which allow experimental modifications or connections.

5.7 CW filter

The CW filter used in this receiver has a 200Hz bandwidth. The circuit is based on the HI-PER-MITE CW filter kit design by David Cripe NM0S, available from the Four State QRP group: <http://www.4sqrp.com/HiPerMite.php> (thanks David for permission to use it here). This is a high performance circuit specifically designed to avoid objectionable ringing.

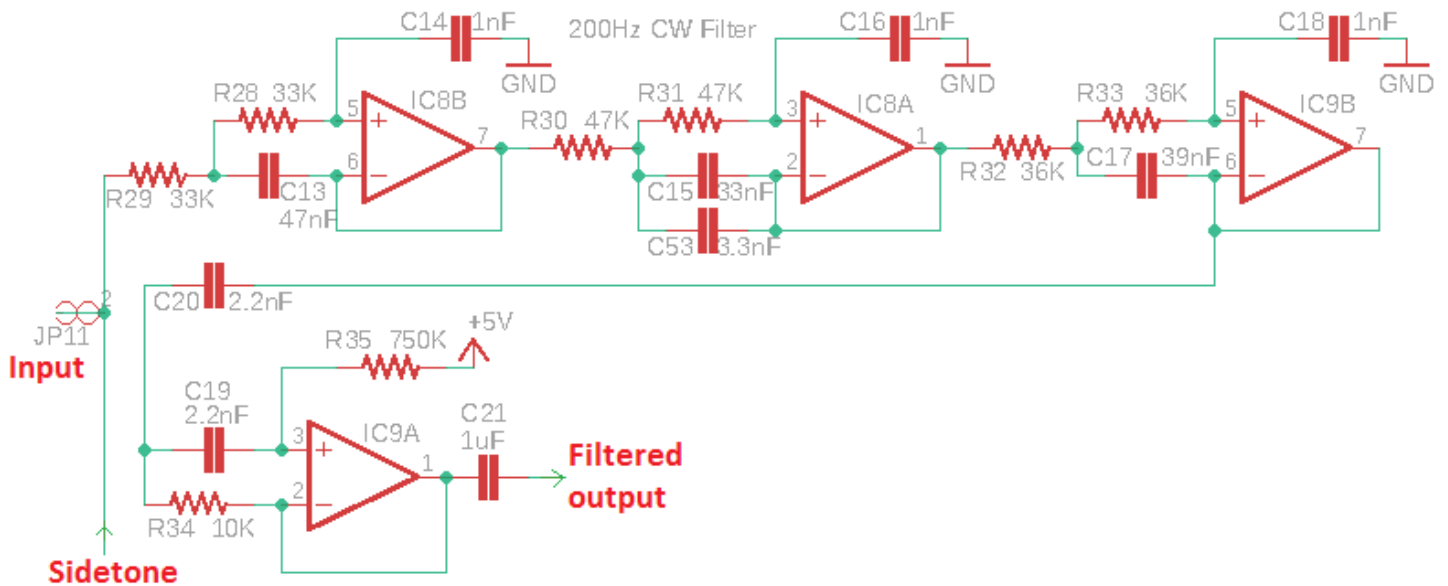

There are three stages of low-pass filtering and one stage of high-pass filtering. The first three stages retain the 2.5V “midrail” bias all the way through from the input transformer T1. The final stage IC9A is biased using the 5V supply (avoiding a few extra components to create a real 6V mid-rail at half the supply).

The CW filter also provides a measured 18dB of gain.

Sidetone is injected at the input to the CW filter, so as to make its sound nice and clean by cutting off the squarewave harmonics leaving a clean 700Hz sidetone.

5.8 Audio amplifier

The final stage in the receiver signal path is the audio amplifier, to drive earphones at a comfortable listening level.

There is a 5K potentiometer on the front panel, used as the gain control. With the wiper fully clockwise the receiver is at full volume. As the potentiometer is turned anticlockwise it forms a potential divider which attenuates the audio signal from the CW filter output. This potentiometer is located on the front panel PCB and is not shown on this diagram section (below).

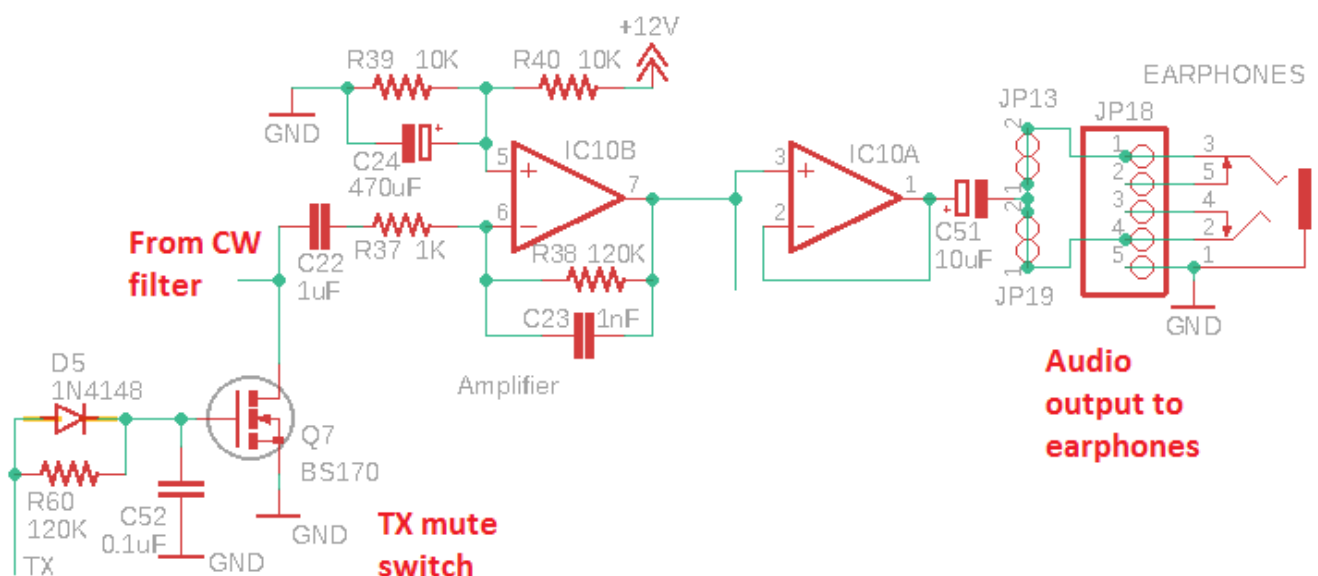

There is also a TX mute switch formed by Q7, another BS170 MOSFET. This was a late addition to the design: despite all attempts, I could not remove the nasty click on receive/transmit switching. The mute switch helps to attenuate it. The switch is operated by the microcontroller Receive/Transmit switch output. When the BS170 switch is on, it has a low resistance to ground which greatly attenuates the audio signal.

To reduce the audio “thump” when the transceiver is switched from transmit back into receive, the mute switch needs to remain switched on for a short while after the receiver is switched back on. A small wait while the thump subsides. This delay is achieved by the R-C network formed by R60 and C52. This would also introduce a delayed switch-on of the mute switch, which would allow the thump when switching to transmit to be heard. To prevent this, diode D5 was added, which bypasses the resistor R60 at the receive-to-transmit switchover. It ensures that at the receive-to-transmit event, the mute switch is enabled instantly; but on the transmit-to-receive switchover there is a short delay.

C21 and C22 were originally 10uF electrolytic capacitors. Some constructors experimented and found that if these capacitors are reduced to 0.1uF the residual Transmit/Receive switchover click is even further attenuated. However, 0.1uF also reduces the gain of the receiver chain by 14dB; although overall the receiver has quite high gain, a loss of 14dB may still be too much particularly on higher frequency bands where the noise levels are lower. Therefore, the current kit is supplied with 1uF capacitors, which provide the click attenuation but have negligible effect on the gain.

IC10B is a simple amplifier configured for 41dB of gain. The ½-V mid-rail bias is created by R39, R40 and C24. Using the 5V power line as “mid-rail” was found to add too much noise. Finally, IC10A is a simple unity-gain buffer. Although it is just an op-amp it is found to be perfectly adequate for driving standard earphones.

The effect of the 5K LINEAR (not Log) volume control and the 1K load resistance of the IC10b input is to create an overall logarithmic characteristic. If you would like a more aggressive logarithmic characteristic or further analysis and discussion on this topic please see <http://www.qrp-labs.com/qcx/qcxmods/qcxvolume.html>

5.9 Transmit signal routing and PA driver

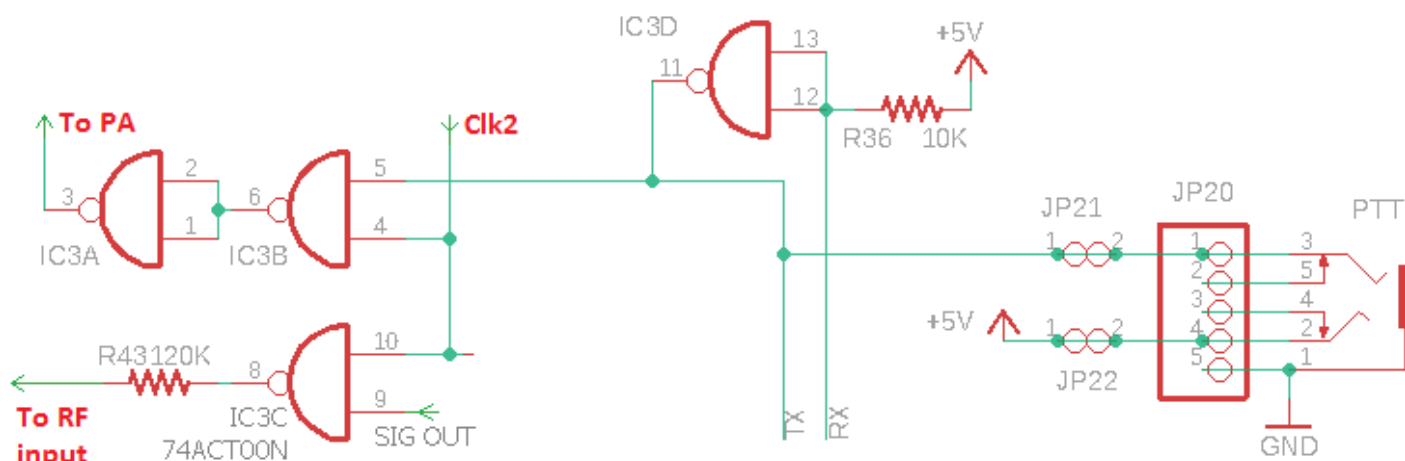

The 74ACT00 is a quad NAND logic gate. The input threshold voltage for a binary “1” is 2.4V which means that the gate is easily switched on by the ~3.3V peak-peak squarewave output from the Si5351A. The output of the 74ACT00 is 5V peak-peak, perfect for driving the BS170 MOSFETs in the Class-E PA into saturation.

The Clk2 signal from the Si5351A is used as the transmit oscillator as previously mentioned. It would have been easy to enable/disable the Clk2 output in software in the Si5351A chip configuration. However, this transceiver design also includes the built-in signal generator feature, for aligning the Band Pass Filter and adjusting the I-Q balance and phase adjustment controls. So, some of the spare gates in the 74ACT00 are used to switch the signal generator on/off and the RF Power Amplifier (PA) signal on/off, separately.

When the SIG OUT control line from the microcontroller is high, the Clk2 signal is enabled as signal generator, and routed via a 120K resistor straight to the RF input of the transceiver.

A TX signal is produced using IC3D as a plain inverter, to invert the logic level "RX" output from the microcontroller and produce a "TX" signal. This TX signal is used elsewhere in the circuit also (audio muting during TX). R36 pulls the RX signal high during the part of a second at power-up that the microcontroller is booting up and has not yet enabled or switched the RX signal high.

When the TX signal is high, the Clk2 signal is routed to the PA. The final inverting gate IC3A is added to make sure that when the TX gate IC3B is off, the driver voltage presented to the BS170 gate is low, so the transistors are off.

5.10 Class-E Power Amplifier

A Class-E power amplifier is a wonderful thing. It has a very high efficiency, sometimes over 90%. This has several important benefits:

- Since not much power is dissipated, we can use smaller (and cheaper) transistors
- So little power is wasted as heat that the requirement for a heatsink is reduced or eliminated
- During transmit the radio requires less current, so the drain on a battery is less – important for people who want to operate portable.

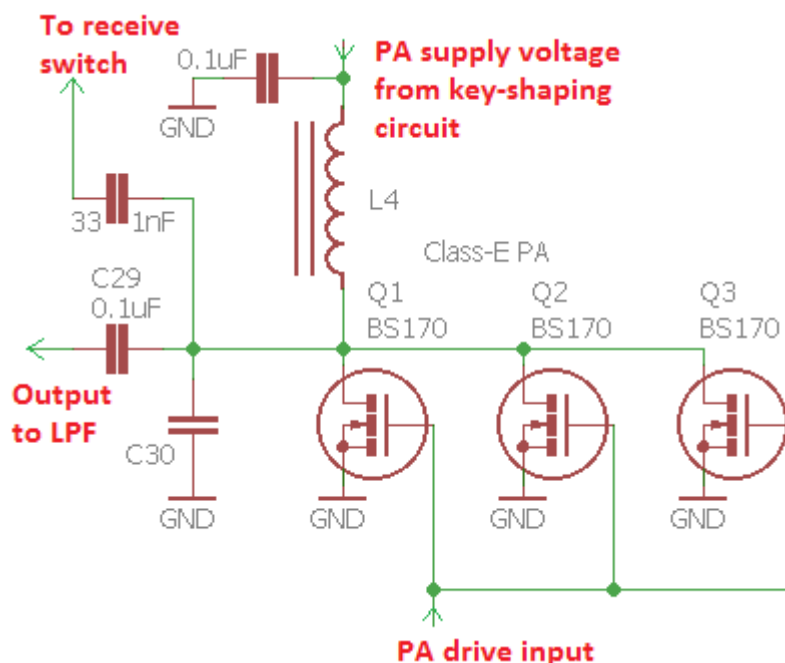

A Class-E Power Amplifier contains a resonant circuit at the frequency of operation, so it is only suitable for single-band use. A lot has been written about Class-E, much of it is very technical and mathematical.

Some excellent background reading are two papers by Paul Harden NA5N:

http://www.aoc.nrao.edu/~pharden/hobby/_ClassDEF1.pdf and
http://www.aoc.nrao.edu/~pharden/hobby/_ClassDEF2.pdf

Paul NA5N describes two defining features of Class-E:

- 1) Use of a square-wave drive to reduce switching losses: the transistors are either on, or off... no lossy region in between

- 2) Reducing the effects of the transistor capacitances. Class-E has a resonant tuned circuit. The capacitance of the transistors, normally an unpleasant lossy aspect, is now a part of the tuned circuit.

Class-E also has a reputation for being difficult to achieve. All those intense mathematics Google will help you find, don't help. In reality, once you realise the secret – it is not so difficult. Calculation of the impedance of a resonant circuit is simple, and there are many online calculators which will do the job for you. For example, <http://toroids.info/T50-2.php> which allows you to type in the operating frequency, and the desired resonant circuit impedance. Then the calculator computes the required inductance, capacitance, and the number of turns required for a certain toroid (in our case we use a T50-2).

The Class-E design process is simple. Choose the output impedance. We choose 50-ohms, because this is the input impedance of the Low Pass Filter we will use. The online calculator will tell you what inductance is needed, and how many turns to wind on the toroid. The online calculator also tells you the required capacitance to bring it to resonance at the operating frequency. Here we resort to experiment, because it is a little difficult to know what the output capacitance of the transistor is. The device capacitance varies depending on supply voltage and whether it is on or off. A simple experiment is required, adding different small capacitances to the circuit, and measuring the efficiency (measure supply voltage and supply current to calculate power input; then measure RF power output. Divide one by the other to get the efficiency). It is easy to find what additional capacitance is required to peak the efficiency. The resonance is quite broad and non-critical.

In this implementation, three BS170 transistors are used in parallel. The BS170 is inexpensive and small, but is rated for 500mA drain current and up to 830mW of dissipation. Per device. Three in parallel provides plenty of capability to achieve a 5W output on a single band.

There are always minor variations between device characteristics from one transistor to the next. If these were bipolar NPN transistors, we would not be able to parallel them in this way. If one transistor takes more of the load and starts to heat up, its resistance further decreases and this causes it to get even hotter. This process is known as “thermal runaway” and results (quickly) in destruction of the transistor. Emitter resistors are used to help balance the load. But with MOSFETs, their resistance INCREASES as the temperature goes up – so there is an inherent self-balancing when multiple devices are used in parallel, without any need for additional balancing resistors which would increase component count and waste some power.

This oscilloscope screenshot shows the classic Class-E waveform. Please ignore the ringing due to poor set-up of the 'scope probes etc. The lower (blue) trace is the 5V squarewave at the gate of the BS170 transistors. The upper (red) trace is the voltage as the BS170 drain. It peaks at approximately 40V in this example. This measurement was done with 12V supply and on 40m (7MHz).

The important point to note is that when the BS170 are switched ON (the gate voltage is 5V), the drain

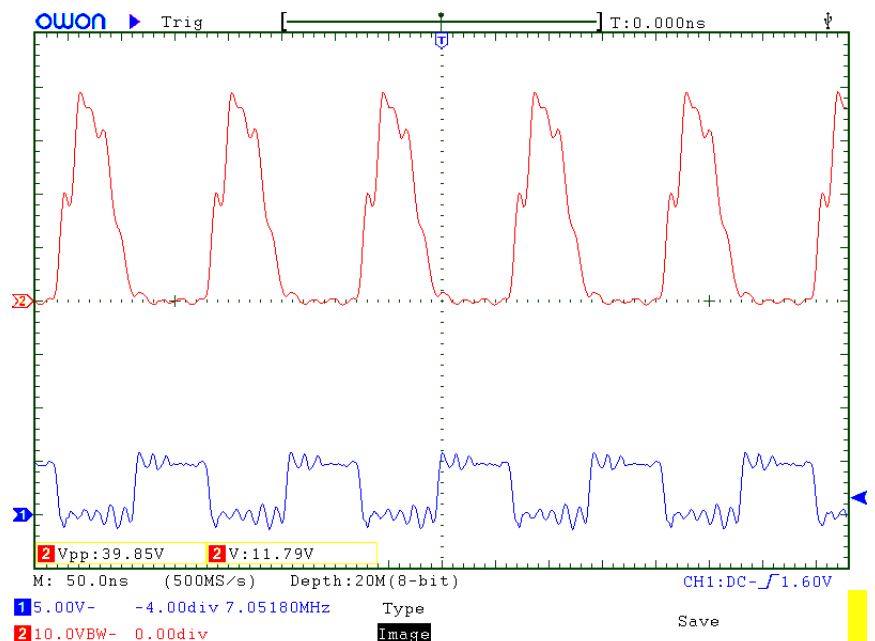

voltage is zero. When the BS170 is OFF the gate voltage pulses nicely to a large amplitude. Class-E!

The summary: Class-E is actually quite easy to achieve in practice! Perhaps all the complicated mathematics might help to squeeze out another % or two of efficiency. But for practical purposes, it's a wonderful building block to use in a single-band CW transceiver.

5.11 Low Pass Filter

The transmitter output is rich in harmonics and must be followed by a good Low Pass Filter, to attenuate the harmonics and satisfy regulatory compliance.

The standard, well-proven QRP Labs Low Pass Filter kit <http://grp-labs.com/lpokit> is used here. To save space and cost, the components are installed directly on the PCB, not on a plug-in board.

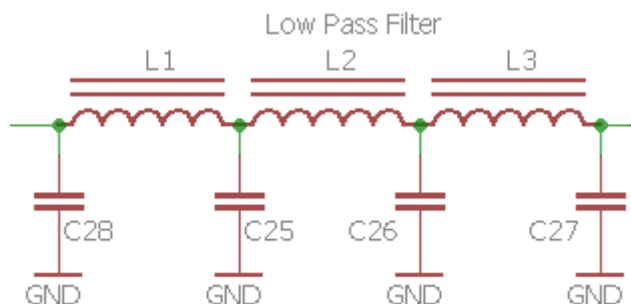

It is a 7-element filter design originally by Ed W3NQN then published for many years on the G-QRP Club web site's technical pages.

5.12 Key-shaping circuit

A hard-keyed CW transmitter generates clicks many hundreds of Hz away from the transmitted signal that can annoy users of adjacent frequencies. This is purely a consequence of the mathematics of the Fourier transform and is unavoidable. Any time you switch a signal instantly on or off, you WILL splatter energy onto unwanted nearby frequencies.

To combat this, any good CW transmitter should include an RF envelope shaping circuit to soften the key-down and key-up transitions. The ideal envelope shape is a raised cosine, but this is difficult to implement without significantly increasing the complexity of the circuit.

The simple key-shaping circuit used here uses only a few components but produces good results.

This circuit was derived from one published by Don Huff W6JL, see <https://www.qrz.com/db/W6JL/> though as he says, "this integrator-type keying circuit is found in many published homebrew designs over the past 40 years or so, so it is nothing new". It uses a PNP transistor (Q6) and R-C integrator circuit. Don W6JL uses this key-shaping circuit to drive a 600W Power Amplifier.

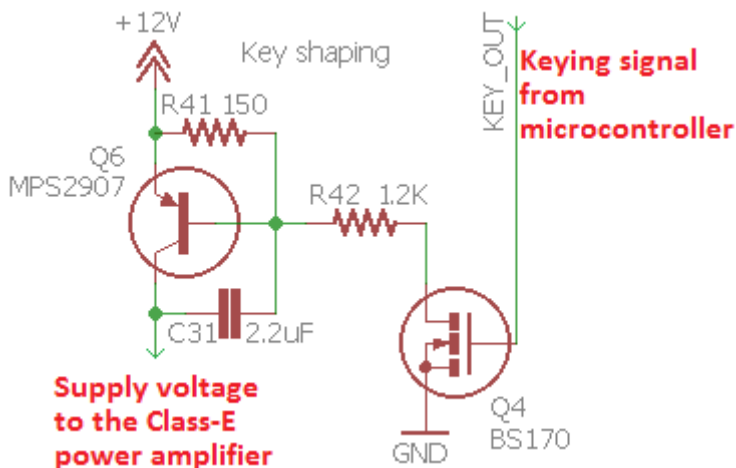

On key down the Q4 switch is "closed" by a high signal coming from the microcontroller. In a really simple transmitter, Q4 could just be replaced by a straight Morse key to ground! But in our case, the microcontroller implements automated stored message sending, beacon modes, and Iambic keyer – so we need the microcontroller to be the boss of everything. The microcontroller reads the state of the straight key or paddle, and processes it to produce a key output. When in straight key mode the

ATmega328P processor

The ATmega328P was chosen because it has enough processing power and I/O to handle all the tasks required here. It is also common and inexpensive, and lots of QRP Labs products already used it, bringing economies of scale in both the kit preparation and the coding. The processor is operated at its maximum rated 20MHz system clock speed.

The code is all written in C and is not open source. While the same ATmega328 processor is used in the popular Arduino Uno products, there is no relation between code written for the Arduino environment and the custom code written for this CW transceiver.

Elimination of tuning clicks

Some constructors of radio receiver projects that use the Si5351A report loud clicks every time the frequency is changed. The cause of these clicks is one or both of two underlying issues:

- a) Faults in the software configuring the Si5351A
- b) Power line or radiated noise from the microcontroller/LCD back into the sensitive receiver

The first of these is not an issue here since we have already extensive experience using the Si5351A and have perfected its configuration.

The second issue is important to address. Every time the microcontroller updates the Si5351A configuration to cause it to change frequency, it typically also writes the new frequency to the LCD. There is a burst of activity in the microcontroller, and on the digital control signals to both the Si5351A and the LCD. The LCD controller chip will also be doing some work to effect the changed display. All of these digital transitions can radiate noise into the receiver front end. Changes in power consumption cause noise on the supply lines which can also be converted into noise detected in the receiver front end.

To combat the radiation issue, the ATmega328P microcontroller is sited away from the RF and audio signal paths, right at the front of the PCB so that the connections between the processor and LCD module and the microcontroller are kept as short as possible, to minimise radiated noise.

To keep noise out of the supply, the 5V supply to the microcontroller and LCD module is filtered by 47uH inductor L6 and 470uF capacitor C47.

In combination, these measures ensure that there are no “clicks” in the audio when tuning the receiver; just a small “flutter” as I call it, which is a natural consequence of the sudden change in frequency (Fourier rules).

Liquid Crystal Display module

The transceiver uses an HD44780-compatible LCD Module with 16 characters by 2 rows. The LCD is operated in the 4-bit mode in order to minimise the I/O pins used. No data is read back from the LCD which means the Read/Write pin can be grounded. In total only 6 I/O pins are used for writing to the LCD.

The LCD is mounted on the front panel PCB and the circuit section (right) is a part of the front panel PCB.

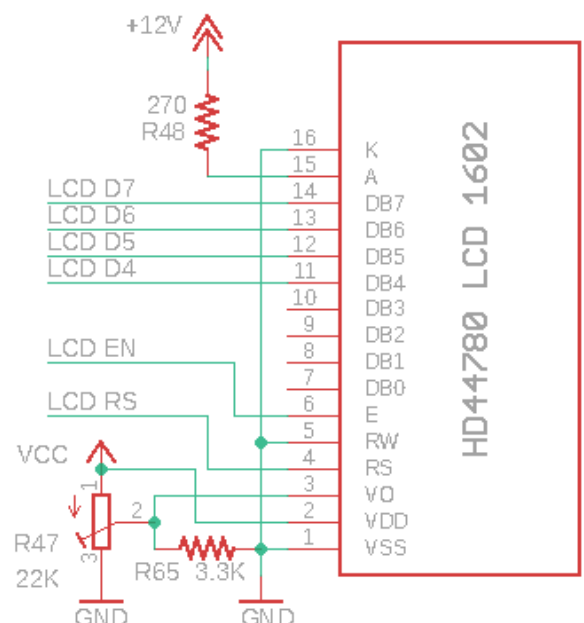

The usual contrast adjustment trimmer potentiometer is R47 and must be set to obtain a readable display.

The LCD backlight consumes about 30 or 35mA of current. The backlight could be connected directly to the 5V supply but this would somewhat increase the power dissipation of the 7805 regulator. In order to avoid overheating the regulator, this backlight is powered instead directly from the +12V rail via R48, a 270-ohm resistor. This resistor value was chosen so that over a supply voltage range of 7 to 20V the backlight brightness still appears reasonable. If you want a reduced brightness display, you could increase the value of R48.

Sidetone

In the early firmware versions of this transceiver, the sidetone was generated by Pulse Width Modulation using the ATmega328's Timer1 peripheral. The frequency and volume of the sidetone were configurable in the software via the configuration menu. In order to control the volume, the microcontroller adjusted the duty cycle from 50% (maximum volume) down to under 1% (for minimum volume).

In firmware version > 1.02 and above, the sidetone generation method was changed. The former method was a simple squarewave, with variable duty cycle, in order to change the volume. However, this also changed the average level, leading to a DC bias at low volume levels; on switching from Transmit to Receive (and indeed, vice versa), the DC bias through the audio chain, being suddenly restored the nominal 2.5V, generated a large click.

The resolution to this was generation of sidetone by superimposing a PWM duty cycle change, for example from 51% to 49%, on a much higher frequency squarewave (42kHz is used at 700Hz for example; the higher frequency is given by 60 x sidetone frequency). This duty cycle change at a rate of 700 times per second, creates a small 700Hz squarewave superimposed on a full size 42kHz squarewave; the average duty cycle is 50% and therefore no click occurs during RX TX switchover. The volume is changed for example, made louder by a larger change in duty cycle; for example 60/40% instead of 51/49%.

The sidetone is injected into the receiver path via a 3.3K resistor at the input to the CW filter. The sidetone generated by the microcontroller is a squarewave, rich in harmonics. As the volume is reduced, the duty cycle percentage drops and the amplitude of the 700Hz fundamental tone also drops. There are many harmonics of course, and the CW filter does a great job of removing these, so what is left in the earphones is a pleasant and pure 700Hz sinewave. This is why the sidetone is injected at the CW filter INPUT.

During transmit, when the sidetone is operational, the mute switch Q7 is also closed – but there is enough leakage through the imperfections of this switch that the sidetone gets through anyway. The 3.3K sidetone feed resistor R59 is chosen to pump enough signal through that it overcomes the attenuation of the mute switch. Without the mute switch, R59 would be a much higher value.

Key paddle, rotary encoder switch buttons

The microcontroller keeps an eye on all the buttons, key paddle inputs, and rotary encoder switches. When button or switch closures occur as the operator activates a control, the microprocessor responds immediately as required.

The paddle inputs, and the rotary encoder switch, are read using dedicated microcontroller I/O signals.

All mechanical switches exhibit switch bounce, where the switch contacts generate multiple transitions for a short time when the switch is activated. It is common to see in many projects, resistor-capacitor networks to debounce switches (including the rotary switch). Simple debounce circuits involving a resistor and a capacitor inevitably involve a compromise when choosing the R-C time constant. It is easy to miscalculate and make the time constant too short (bounce noise still gets through) or too long (rapid switch closures are missed). In some cases it is impossible to find the sweet spot in between these two extremes.

In my opinion, resistor/capacitor debouncing is a poor solution to the problem, when the circuit contains a microcontroller. It is easy to debounce the switch edges in software! This allows you to control time-constants or other debounce logic much more precisely. Of course, it saves those additional resistors and capacitors too, which all helps reduce the cost and complexity of the kit! This is the reason why in this kit, you will not see any resistor or capacitor debouncing of any of the controls. Everything is done in the software.

The rotary encoder is debounced using a state machine, rather than any timing loops. The rotary encoder produces two switch-closure outputs which have a 90-degree (quadrature, again) phase shift. The microcontroller can monitor these transitions and determine the number of “clicks” of the rotary encoder, and the direction the knob was turned in, and at the same time debounce the switch transitions.

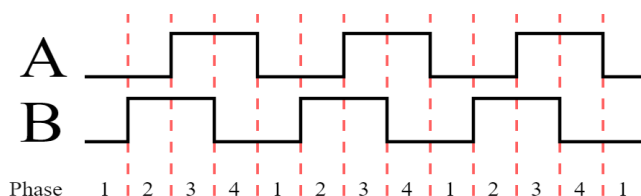

Another unnecessary component often seen is a pullup-resistor on a switch signal to a microcontroller, so that when the switch is open (not pressed) the microcontroller sees a “high” voltage. This is unnecessary because modern microcontrollers such as the ATmega328P all contain configurable internal pull-ups!

I had a little more trouble when it came to the “Select”, “Rotary” (shaft of the rotary encoder) and “Exit” push-buttons. Despite thinking that the microcontroller had plenty of I/O signals available, when I came to implement all the features I had in mind, I realised there weren’t enough I/O signals to read the buttons!

The solution was to analogue-multiplex all three buttons onto a single input signal to the microcontroller, which is one of the Analogue to Digital Converter (ADC) channels. No microcontroller internal pull-up is used because I need to have precise control over the voltage levels.

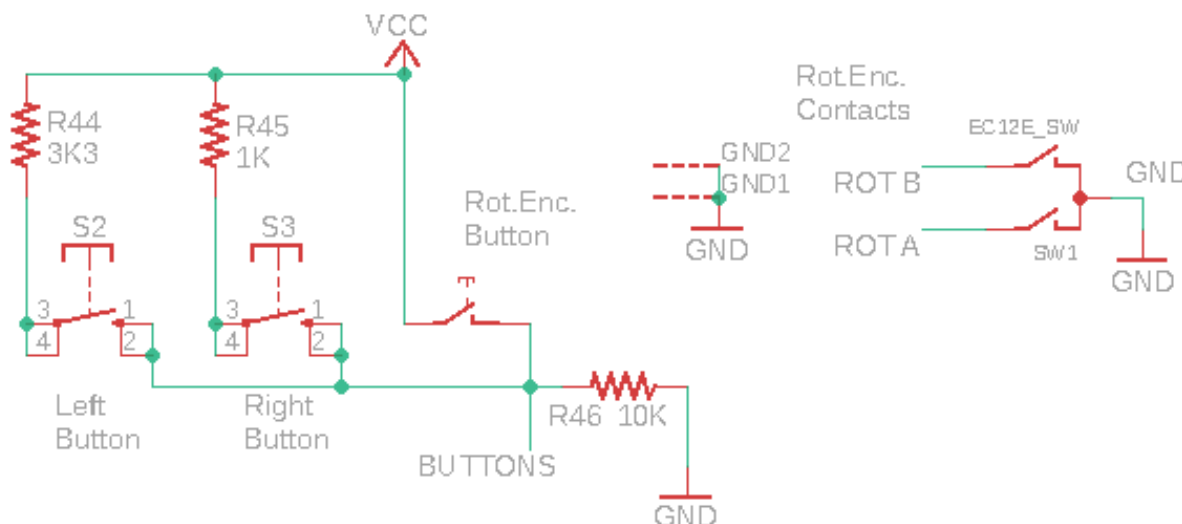

The circuit fragment below shows the rotary encoder, and the three buttons (two tactile switch buttons, plus the button internal to the rotary encoder shaft) which are located on the front panel PCB.

The input signal is pulled low by a 10K resistor R46. One side of all three buttons is connected to the I/O pin. The other sides of the buttons are connected to 5V via different resistors: 3.3K (R44) for the left (“Select”) button, 1K (R45) for the right (“Exit”) button, and direct connection for the centre (“Rotary”) button. When one of the buttons is pressed, the resistors form a potential divider that sets the voltage to the microcontroller depending on which button is pressed. Some calculation results in the following table of voltages depending on which button is pressed:

Button pressed	Voltage
None	0.00V
“Select”	3.76V
“Rotary”	5.00V
“Exit”	4.55V

In all three cases, the voltage when a button is pressed, is higher than the 3V logic “1” threshold of the microcontroller. I am able to use a pin-change interrupt to detect that a button has been pressed, then read the ADC channel 3 and compare the measured voltage to the table, to determine which button was pressed.

It’s a nice trick for reading multiple buttons on a single ADC input, and it would work also for a larger number of buttons! Each one just needs a different resistor value and eventually, some care would need to be taken to ensure that the voltage differences could be read reliably, not masked by ADC noise or component inaccuracies. For three buttons, none of these problems arise.

TX/RX Switch control, and Key Out signals

As already discussed, the Key Out signal either reflects directly the state of a straight key, in Straight keyer mode, or it is a processed keyer signal when using the lambic keyer modes or Beacon function of the transceiver. The Key Out signal is generated by the microcontroller with precise timing in the Beacon and lambic keyer modes. It is routed to the RF envelope key-shaping circuit discussed previously.

The Transmit/Receive switch must remain in “transmit” state for a short time after key-up, in order for the RF envelope of the key-shaping circuit to drop gently down to zero, which takes approximately 5ms. Due to this, the microcontroller implements a 10ms delay between key-up and switching the radio back to receive mode.

The diagram (right) illustrates the relationship between these signals, for an example 24 words per minute “dit”. The Key out signal has a “high” period of 50ms exactly. The ramp-up and ramp-down

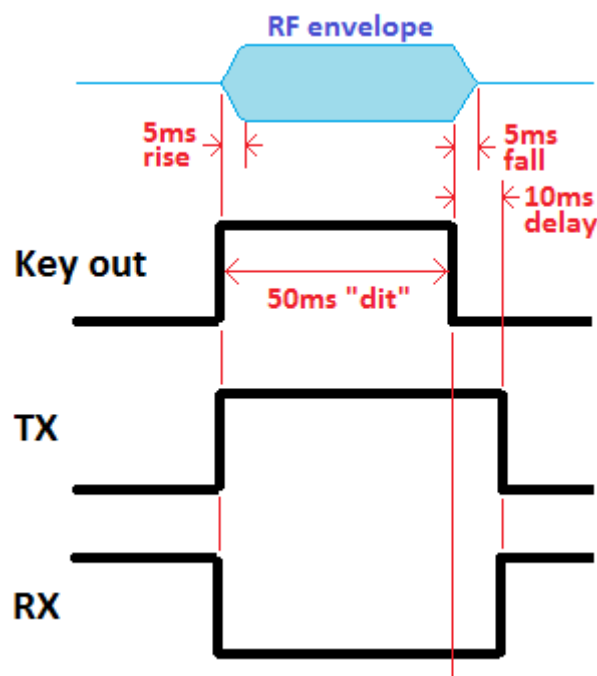

of the RF envelope has 5 millisecond (approximately) rise and fall times. The “RX” control line generated by the microcontroller switches on the receiver (allows RF through to the receive mixer) when it is “high”. It is held in the “low” (transmit) state for 10ms after key up completes.

The “TX” signal is the inverse of the “RX” signal, and it switches the gate of the audio mute switch Q7 during transmit. One of the NAND gates IC3D is used as the inverter to create the “TX” signal from the microcontroller’s “RX” output.

5.14 Optional GPS interface

The GPS was a late addition to the design. It is added to facilitate several useful features:

- Calibration of the 27MHz reference oscillator
- Calibration of the 20MHz system clock
- For WSPR, discipline of the frequency (drift correction)
- For WSPR, setting and discipline of the real time clock
- For WSPR, setting the Maidenhead Locator square

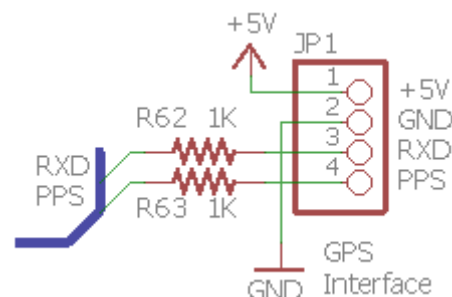

The optional GPS interface is provided by a 4-pin header at the bottom right of the board, next to the 3.5mm socket for the keyer. The pinout of the 4-pin header exactly matches the one on the QRP Labs Ultimate3S QRSS/WSPR transmitter kit, and the QRP Labs QLGr-series GPS receiver kits. This makes connecting the radio to the QLGr GPS kit very easy, if you wish. However other GPS modules could also be used. The following requirements of the GPS module must be met:

- Positive-going (leading edge) 1 pulse per second signal with a reasonable pulse width – e.g. some older GPS module have a 1us pulse and this will not be long enough. The QLGr GPS receiver provides a 100ms (0.1s) duration pulse, though shorter pulses would also work.
- 9600 baud serial data sending standard NMEA 0183 GPS sentences
- “TTL” voltage levels i.e. 0V “low” and 5V “high” (or at least, below 1.5V and above 3.5V)

The 1pps and Serial data signals from the GPS are connected via 1K resistors, to the “dit” and “dah” inputs to the microcontroller. The GPS is therefore wired directly in parallel with the paddle. The GPS may not be used at the same time as the paddle. This would cause the transmitter to be keyed by the 1pps and serial data signals. The 1K resistors protect the GPS outputs in case the paddles inadvertently ground them. **Always put the kit into Practice Mode (see menu 4.7) before connecting a GPS, to avoid accidentally frying the PA.**

The ATmega328P has a USART serial data peripheral. However, the pin assignments were already made, so far down the design process, at the time the GPS receiver option was included. Furthermore, the I/O pin availability was already scarce. So, the two GPS signals share the same I/O as the paddle inputs. A software-emulated USART peripheral module now reads the GPS serial data, at 9600 baud.

If you connect a GPS and forget to put the kit in practice mode, it will automatically recognize serial data at the paddle input and temporarily enable practice mode (a P appears in the display) to protect the PA circuit.

5.15 In Circuit Programming (ISP) interface

A 2x3-pin header is installed on the PCB to facilitate In Circuit Programming (ISP) of the ATmega328P microcontroller in future, if new firmware versions become available.

Firmware updates can be done with a simple USBISP AVR programmer available from eBay for under \$2 including international shipping. The 2x3-pin header pinout matches the standard AVR programmer cables.

The ISP interface uses the same I/O pins as the GPS interface and the Paddle. When upgrading the firmware, be sure to disconnect the GPS (if you had one connected). And do not press any paddle key while doing the firmware update!

Some AVR programmers require a 5V connection to sense the target programming voltage; some do not. +5V is connected to pin 5 of the ISP header, via 2-pin header pads JP28. If you do not want this connection in your particular case, you can cut the track between the two pads to break the +5V connection.

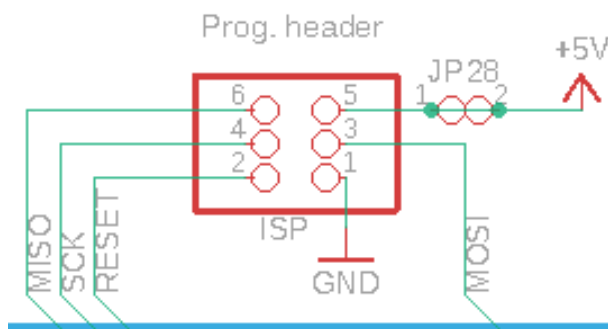

5.16 Test Equipment

The built-in test and alignment equipment is a really nice feature of this CW transceiver kit.

DVM and RF Power meter

The DVM and RF Power meter is implemented using the 10-bit ADC channel 2 input to the microcontroller.

When measuring voltage, connect the voltage to be measured to pin 3 of the 3-pin DVM/RF Power connector. The voltage is dropped by the potential divider formed by R56 (3.3K) and R57 (10K). This applies a division by a factor of 4.03. Since the ADC can measure voltages up to 5V, this means the DVM function has a range of 0V to 20V maximum, and each ADC bit has a resolution of 0.02V.

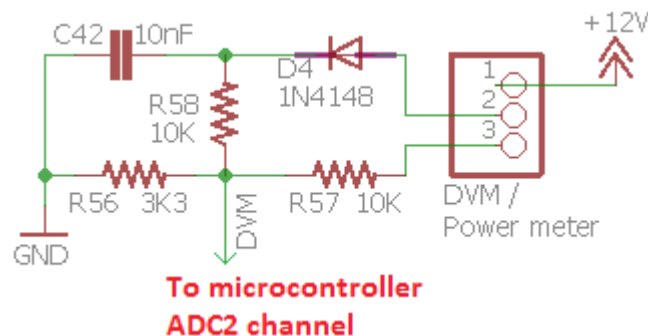

When measuring RF power, connect the RF to be measured to pin 2 of the 3-pin DVM/RF Power connector. In this case D4 and C42 form a simple RF detector. The RF is rectified by D4 and smoothed by C42. R56 (3.3K) and R58 (10K) again form a potential divider that divides the rectified voltage by a factor of 4.03. The resulting range of the power meter is from 0 to 5W approximately.

For normal operation of the radio, if you wish to see a battery voltage icon on screen, then connect pin 1 to pin 3 of the 3-pin header. This connects the voltmeter input to the 12V supply of the radio.

In the unlikely event of accidentally overloading the RF power input or the DVM input, the 10K resistors R57 and R58 limit the damage to the ATmega328P processor or maybe prevent damage altogether. Perhaps. (don't feel tempted to try it intentionally).

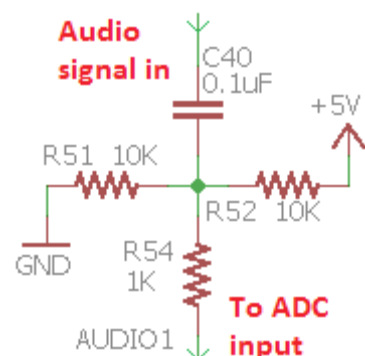

Audio ADC

There are two audio connections from the receiver signal chain to the microcontroller. One is connected at the output of the I-Q balance adjustment potentiometer. In other words, the input to the CW filter. The second audio connection is connected after the final audio amplification gain stage. Both of these audio signal channels are fed to Analogue to Digital Converter (ADC) inputs of the microcontroller.

The circuit diagram (right) shows the circuit at AUDIO 1 (ADC channel 0) which is connected to the audio amplifier output. The purpose of the circuit is to remove the DC bias from the audio signal, and apply a new bias of 2.5V, to bias it to the middle of the ADC's input range. The 1K resistor in series with the ADC pin is intended to provide some kind of limited protection to the microcontroller in the event that the voltage falls outside the range 0-5V. A simpler circuit is used on the AUDIO 2 channel as the DC bias is already 2.5V so the signal is within the range 0-5V.

The ADCs in the ATmega328P have 10-bit resolution which translates to about 5mV. The ADC conversion result is a number in the range 0-1023, with 512 representing zero. An audio voltage of +/- 2.5V can therefore be measured. In practice, the audio signal is much less than this, which means the full ADC range is not really used. The AUDIO2 channel (connected at the CW filter input) has even less amplitude so is not used for anything except the BPF Alignment procedure, which has a very strong signal.

Frequency Counter

The frequency counter test pin input is connected directly to the microcontroller's 16-bit Timer1 input pin.

There is a 1K series resistor (R55) to connect it also to the Si5351A's Clk2 output. This is used during the optional GPS-disciplined 27MHz reference crystal frequency measurement. In this function, the Si5351A is configured to route its raw 27MHz output, divided by 4, to its Clk2 output. This passes through the 1K resistor R55, to the microcontroller. The 1K resistor provides protection to the Si5351A in the event you accidentally have something connected to the FREQ input pin, and the Si5351A is operating its Clk2 output at the same time.

Since the 3.3V peak-peak signal from the Si5351A is rather marginal for operating the Timer1 input, a 3.9K pullup resistor increases its centre point. Now "low" is 1.02V and "high" is 3.65V, which is enough to trigger the Timer1 input reliably.

The frequency counter can operate from 0 to 8MHz theoretically, assuming a clean 50% duty-cycle squarewave signal of sufficient amplitude. The 8MHz upper bound is a limitation of the AVR processor which has a synchronous timer input, and can only count to 40% of the system clock frequency (40% of 20MHz is 8MHz).

The signal to be counted must satisfy the logic thresholds of the ATmega328P, namely a "low" or "0" is less than 1.5V, and a "high" or "1" is greater than 3.5V.

Signal Generator

The signal generator mode was also discussed in the operating manual section. The signal output is simply taken from the Clk0 or Clk1 output of the Si5351A. Care should be exercised not to draw excessive load (e.g. short circuit) from these pins, which could damage the Si5351A. It will be very difficult to replace a damaged Si5351A.

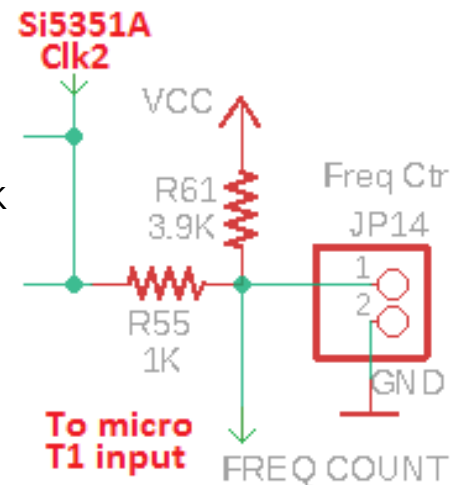

Self-test of Signal Generator and Frequency Counter

Note that once the Signal Generator has been activated by scrolling to the Signal Generator menu item, and pressing the “Select” button to enable it – the Signal Generator remains active on the set frequency, until you press the “Exit” button and leave the Test Equipment menu.

Press the “Select” button to enable the signal generator; an underline cursor appears under the digit that will be tuned by the rotary encoder. Adjust the signal generator to produce a frequency some way under 8MHz. Let’s say, 6MHz. When you leave edit mode, by pressing the “Select” button until the cursor disappears off the right side of the 1’s digit, OR by pressing the “Exit” button, then the cursor will no longer be shown on the display. Turning the rotary encoder 1 click anticlockwise shows menu 9.5, the frequency measurement. Now if you connect a wire from the FREQ input to the CLK0 output, you will measure the signal generator’s frequency. This is shown here in the photograph (right, original QCX not the QCX+); clearly the 2kHz low reading indicates I have not calibrated the 27MHz reference value and/or the 20MHz system clock value!



In the photograph, the white wire shown looping around the rotary encoder connects the FREQ pin (just under the “M” character of the LCD, in the photograph) to the Clk0 output pin (just under the “z” character of the LCD).

This is a convenient way to get the frequency counter to verify the correct operation of the signal generator (and hence the Si5351A synthesiser). The signal generator output is available at both the Clk0 and Clk1 pins, hence you can test them both.

5.17 5V voltage regulator

5V for the microcontroller, Quadrature Sampling detector chip, LCD module and IC3 (quad NAND gate) is provided by IC11, a 7805 5V 1A voltage regulator.

Note that the input is protected against reverse polarity by D3, a Schottky diode type 1N5819. This also drops the voltage by 0.3 to 0.4V, which has the effect of reducing the output power. D3 is shown on the microcontroller section of the circuit diagram, see earlier.

If you are brave, and confident that you will NEVER connect power to the radio with reversed polarity, you can omit this diode and fit a jumper wire over it.

The route of power through the switching and regulator circuits is as follows:

- Power enters the QCX+ at the 2.1mm power connector on the rear panel.

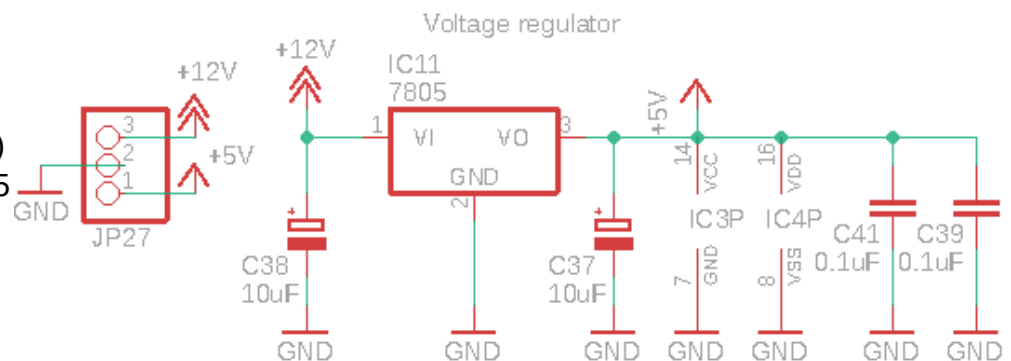

- A 3-pin header pad connector could be fitted at JP26 to provide un-switched power to additional boards; or if you wish to manage power switching in other ways, the thin trace between pins 1 and 2 of this 3-pin header could be cut.
- D3 (1N5819) provides reverse polarity protection and can be omitted if you wish, just bypass it with a jumper wire. You will gain some power output since the diode's 0.3 or 0.4V loss will be removed. But your QCX+ will have no protection against a reverse power accident.
- A 2-pin header pad connector JP15 can also be used to provide polarity-protected, un-switched power to another PCB above, or the trace between the pads could be cut to provide switching control elsewhere.
- 2x5-pin connector JP3 now routes the 12V power to the front PCB
- A latching push-switch on the front panel acts as the On/Off switch for the QCX+
- The switched power now returns to the main QCX+ PCB again via the 2x5-pin connector JP3
- The switched +12V power is connected to the 7805 and the rest of the circuit. There is also a 3-pin header JP27 which may be used to connect this switched power to additional PCBs for modifications etc.

6. Fault-finding

Refer to <http://grp-labs.com/qcx/qcxtrouble> and the groups.io discussion group for more tips!

6.1 Blank LCD or blocked LCD

If your LCD screen looks like either of these, then it is a sure sign that you have not adjusted the contrast trimmer potentiometer R47.

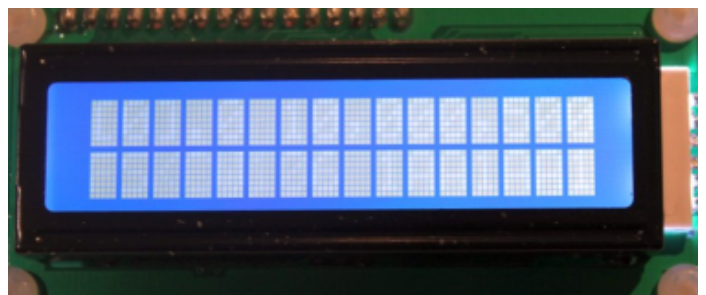

6.2 No backlight at all

If there is no LCD backlight at all, check that you have installed R48, and also check that you have properly installed the LCD connector between the main PCB and the LCD module.

6.3 A row of blocks appears on the top row

If you see a row of blocks along the top of the LCD module, and the bottom row is empty, this means that the microcontroller has not communicated with the LCD module.

Check that your IC2 microcontroller is correctly installed in its 28-pin socket, with the correct orientation (dimple on the chip matches the dimple on the socket and the PCB silkscreen). Check that all of the pins of IC2 are correctly inserted in the socket, not bent.

6.4 DC voltage readings

The following table lists the DC voltage read at various points around the circuit. This may aid troubleshooting. The voltage measurements were made using the in-built DVM, in menu item 9.1. These measurements were made using a 12V power supply.

Where an IC pin number is mentioned, remember that pin numbers start from the top left (just to the left of the dimple at the end of the chip) and are counted anticlockwise from there (see diagram of 8-pin IC for example, right).

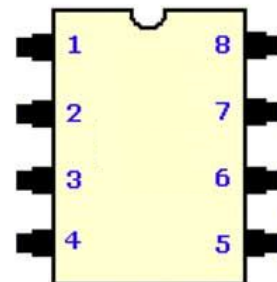

Where “left”, “right”, “top” and “bottom” are mentioned, they assume the PCB is orientated in the normal way.

All measurements were made probing the PCB from the top side. In some cases, poke the wire to touch the pad of a particular capacitor or resistor.

References to the pinout of transformer T1 use the nomenclature indicated in the diagram (right).

In many cases these measurements may not exactly match your own. In particular if you use a power supply other than 12V, then voltages which are derived from the 12V supply line will be different. For example, bias voltages on op-amps which are biased to half the supply rail.

Bear in mind that in some of these measurements, the act of measurement will itself change the measurement. The “input resistance” of this DVM is only 13.3K (R56 and R57 in series, assuming high input resistance of the microcontroller pin). If you were to make these DC measurements with a high input resistance “real” DVM rather than the inbuilt DVM of this radio transceiver, these measurements would change. Again: if your measurement is in the right ballpark, do not worry if it differs from these.

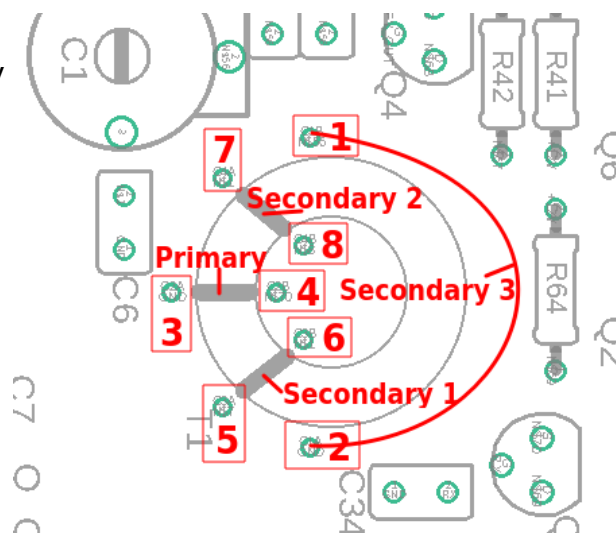

When making these measurements, be very careful that whatever wire you are using to probe the circuit does not cause shorts to adjacent pins or components, which could cause damage.

I suggest avoiding directly probing the Si5351A chip pins, they are just too small: the risk of shorting adjacent pins is high. You can easily probe nearby components which are connected to the Si5351A pins, if you wish – refer to the PCB tracks diagram. Similarly, I do not recommend directly probing the FST3253 pins. Again, it is easy to probe nearby components which are connected to those pins, and reduces the risk of damaging something by causing inadvertent short circuits.

Location	Voltage	Comment
+ supply terminal	11.98	As I already mentioned: a 12V supply
Clk0 test pin	~1.70	The Clk0 pin in normal operation has a 3.3V peak-peak squarewave with 50% duty cycle. The DVM is measuring the average of that. Measuring here makes a lot of nasty noise in the audio.
Clk1 test pin	~1.70	The Clk1 pin in normal operation has a 3.3V peak-peak squarewave with 50% duty cycle. The DVM is measuring the average of that. Measuring here makes a lot of nasty noise in the audio.
Left side of C2	3.40	This is the voltage of the Si5351A supply, pins 1 & 7
Right side of D2	4.96	This is the +5V regulated supply
T1 pins 1, 2, 3 & 4	0.00	
T1 pins 5, 6, 7 & 8	2.36	
Top side of C43	2.28	C43-46 are the QSD integrating capacitors. The voltage across each one differs slightly. The following measurements show these small differences.
Top side of C44	2.44	
Top side of C45	2.42	
Top side of C46	2.30	
IC5 pin 1	2.64	IC5a output, the pre-amp I output
IC5 pin 2	2.46	
IC5 pin 3	2.26	
IC5 pin 4	0.00	
IC5 pin 5	2.28	
IC5 pin 6	2.46	
IC5 pin 7	2.44	IC5b output, the pre-amp Q output
IC5 pin 8	11.67	This is the supply voltage minus the voltage drop caused by the reverse polarity protection diode D3
IC6 pin 1	2.44	IC6a output
IC6 pin 2	2.44	
IC6 pin 3	1.63	
IC6 pin 4	0.00	
IC6 pin 5	1.55	
IC6 pin 6	2.44	
IC6 pin 7	2.44	IC6b output
IC6 pin 8	11.67	
IC7 pin 1	2.64	IC7a output
IC7 pin 2	2.64	
IC7 pin 3	1.99	
IC7 pin 4	0.00	
IC7 pin 5	1.89	
IC7 pin 6	2.64	
IC7 pin 7	2.64	IC7b output
IC7 pin 8	11.67	
IC8 pin 1	2.46	IC8a output
IC8 pin 2	2.46	
IC8 pin 3	0.65	
IC8 pin 4	0.00	
IC8 pin 5	0.67	
IC8 pin 6	2.48	
IC8 pin 7	2.48	IC8b output
IC8 pin 8	11.67	

IC9 pin 1	4.84	IC9a output
IC9 pin 2	4.84	
IC9 pin 3	0.65	
IC9 pin 4	0.00	
IC9 pin 5	0.67	
IC9 pin 6	2.44	
IC9 pin 7	2.44	IC9b output
IC9 pin 8	11.67	
IC10 pin 1	5.83	IC10a output
IC10 pin 2	5.83	
IC10 pin 3	5.83	
IC10 pin 4	0.00	
IC10 pin 5	4.21	
IC10 pin 6	3.94	
IC10 pin 7	5.83	IC10b output
IC10 pin 8	11.67	
LCD pin 1 (leftmost)	0.00	LCD VSS supply pin
LCD pin 2	4.94	LCD VDD supply pin
LCD pin 3	0.57	LCD Contrast
LCD pin 4	4.92	LCD RS pin
LCD pin 5	0.00	LCD RW pin
LCD pin 6	0.00	LCD E pin
LCD pin 7	1.08	LCD DB0 pin
LCD pin 8	1.08	LCD DB1 pin
LCD pin 9	1.06	LCD DB2 pin
LCD pin 10	1.04	LCD DB3 pin
LCD pin 11	0.00	LCD DB4 pin
LCD pin 12	4.94	LCD DB5 pin
LCD pin 13	4.92	LCD DB6 pin
LCD pin 14	0.00	LCD DB7 pin
LCD pin 15	4.41	LCD backlight anode
LCD pin 16 (rightmost)	0.00	LCD backlight cathode

6.5 RF Power output check

If you go into menu “9.2 RF Power”, you can check your RF power output. Your RF output should preferably be connected to a dummy load, since the RF power calculation assumes that the voltage is across a 50-ohm load.

In the top right corner area of the PCB, you will find a pad on the PCB to which the L1 wire is soldered. This pad is connected directly to the RF output pin of the BNC connector (see diagram). If you connect a wire from here, to pin 2 of the 4-pin DVM/RF Power header, then key-down, the display will read the power output in Watts. It is easiest to have the transceiver in Straight key mode and squeeze the paddle.

Remember that the simple diode RF detector is not likely to be particularly accurate. But if you see a reading of a few watts, it will give you confidence that your transmitter is working properly.

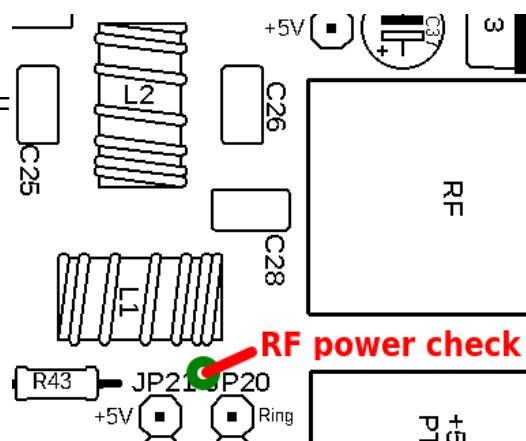

If you do NOT see any power output on key-down, then you probably have a fault in the Power Amplifier. A common mistake, as I mentioned previously during the assembly steps, is failure to remove or burn off the enamel insulation on the enamelled copper wire wound onto the toroids.

Check the RF power wire touched to the BS170 drains first (see diagram). You can still touch the wire to these BS170 drains from the top side of the board. Key-down and check the wattage reading. At this point the indicated power will be even less reliable than across the dummy load. But at least see if it reads some watts.

If you see power output at the BS170 drains, but not at the overall transceiver RF output, then this means that the fault lies in the Low Pass Filter. Check the soldering and the enamel situation, on those toroids.

If you do not even see power output at the BS170 drains, then perhaps the L4 drain inductor in the PA has incorrectly soldered wires, that have not made an electrical connection – so check the L4 wires first and make sure the enamel is properly scraped or burnt off, to make a proper connection.

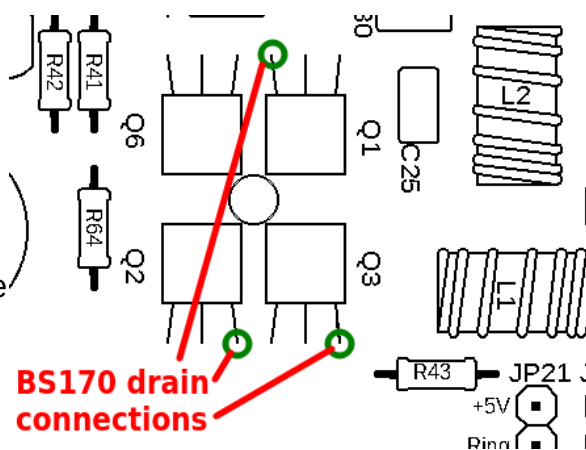

7. Measurements

The measurements in this section were performed on assembled kits. There will always be differences from one kit to the next, due to component tolerances, adjustment differences, how you wound toroids, etc. In addition, it is often difficult to make good RF measurements. Therefore, everything you read in this section should be interpreted as an INDICATION only. Your actual results may (and probably will) differ. The following information just gives a guide of very roughly, what you might expect to see.

7.1 Equipment

For reference, and for the sake full disclosure, the following equipment was used in making these measurements:

- OWON XS3102A 12-bit 100MHz Digital Storage Oscilloscope
- ADVANTEST R3361C 2.6GHz Spectrum Analyser with 50-ohm tracking generator
- QRP Labs 50-ohm Dummy Load kit <http://qrp-labs.com/dummy>
- XONAR U5 24-bit external USB sound card
- Argo and Spectran audio analysis software from <http://weaksignals.com>
- QRP Labs Ultimate3S for test signal generation <http://qrp-labs.com/ultimate3/u3s>
- Simple 14.000MHz battery-powered crystal oscillator signal generator
- Two generic yellow DVMS
- 12V fixed power supply, and variable voltage bench supply

7.2 Transceiver current consumption

The current consumption of your radio may be an important consideration if you intend portable battery-powered operation. Current consumption depends on supply voltage.

These measurements were carried out on a 40m band version of the kit. They will not differ much for other bands. At 13.8V supply for example, current consumption is about 140mA on receive, and almost 500mA on transmit.

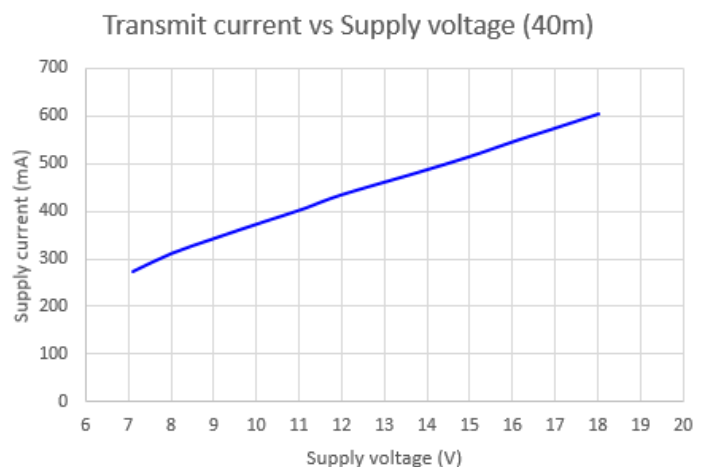
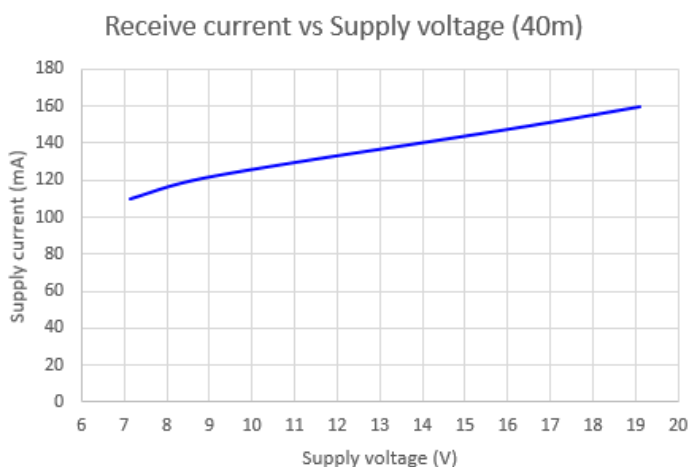

At supply voltages above 13.8V, check the temperature of the 7805 voltage regulator, which may need a heatsink as it dissipates more heat at higher supply voltages, if you are not using the official QRP Labs QCX+ enclosure and bolting the regulator to the heatsink.

7.3 Transmitter power output

The transmitter RF power output varies depending on the power supply voltage. It is also dependent on band. Your results may vary depending on your Low Pass Filter inductor construction! If the cut-off frequency becomes too low, then you can start to get attenuation at the operating frequency. In this case you can remove a turn or two from each toroid.

The following charts show the power measurement using the oscilloscope to measure the peak-peak amplitude across the 50-ohm dummy load.

Operation at output power levels above 5W is NOT recommended, as it will put too much strain on the BS170 output transistors which may result in failure. For this reason, limiting the supply voltage to not more than 15 or 16V is recommended.

Note that these measurements do not take into account the D3 1N5819 reverse polarity protection diode voltage drop (approximately 0.3 or 0.4V). In other words, the measurements were done in a transceiver with D3 bypassed by a wire link.

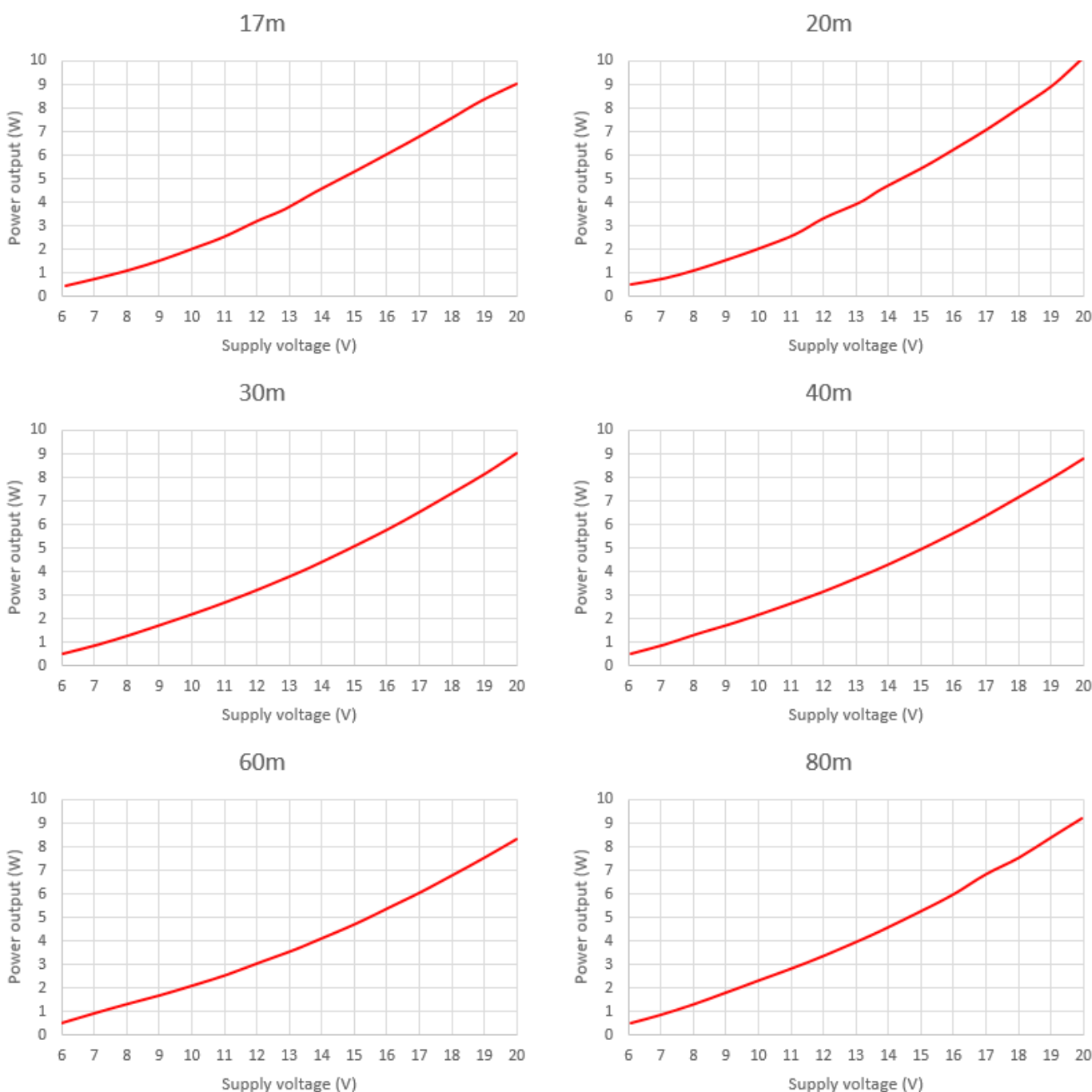

7.4 Class-E Power Amplifier drain waveform

This oscilloscope chart shows the waveform at the BS170 drains (top, RED colour trace) and the input drive waveform, a 5V peak-peak squarewave (bottom, BLUE trace). The 40m band is shown.

Upon ignoring the “ringing” artefacts due to poor ‘scope probes etc., the waveforms are correct for Class-E operation.

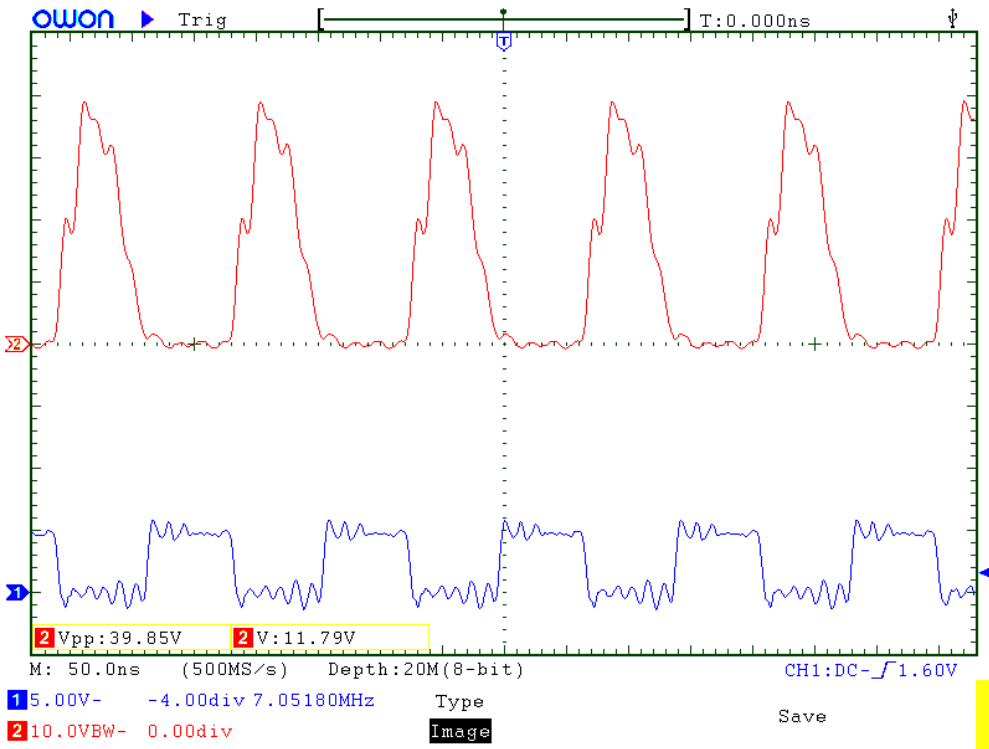

7.5 RF envelope key-shaping

The following oscilloscope images show the RF envelope when keyed with a continuous 24 words per minute (50ms duration) string of dits. The simple key-shaping circuit described earlier results in rise/fall times of around 5ms and significantly attenuates key-clicks.

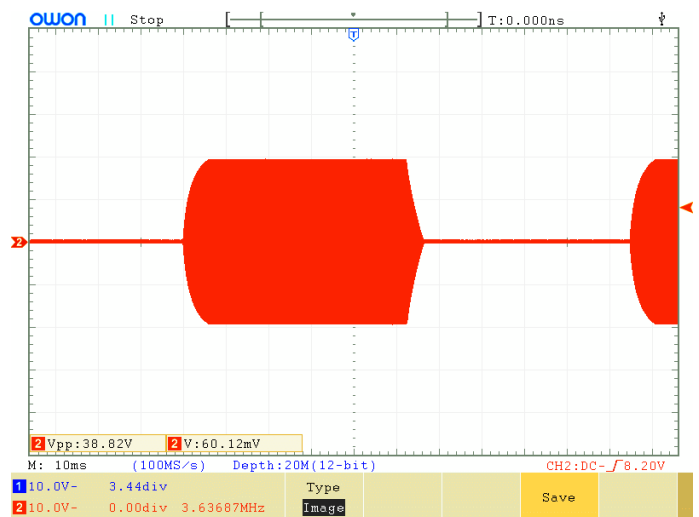
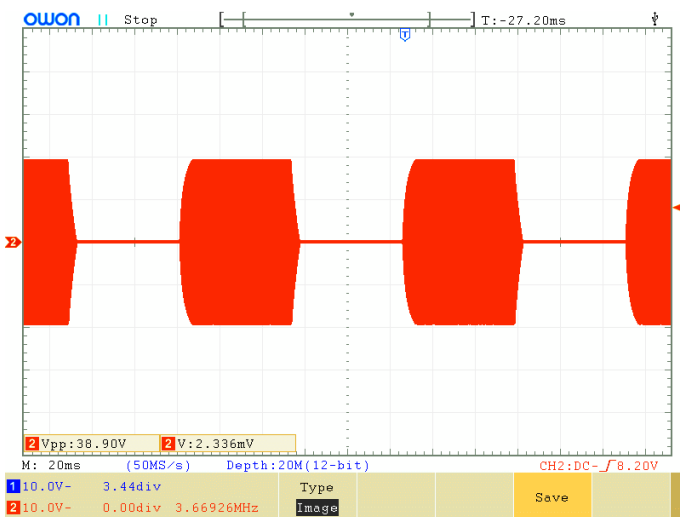

7.6 Low Pass transmitter harmonic output filter characteristics

The Low Pass Filter response was not measured. The Low Pass Filter is the same as the QRP Labs Low Pass Filter kit module <http://qrp-labs.com/lpokit> . Measurements of the Ultimate3S kit <http://qrp-labs.com/ultimate3/u3s> using these filters is on this page <http://www.qrp-labs.com/ultimate3/u3info/u3spec.html>

7.7 Band Pass receiver input filter characteristics

The following charts show measurements of the simple band pass receiver input filter implemented using transformer T1. For each band, one image shows the close-in response, the other shows the response across 0 to 30MHz.

Note that in the circuit, the Band Pass filter sits behind the Low Pass filter. Therefore, the low pass filter response is ADDED to the band pass filter response. These charts show a relatively poor attenuation above the passband – but this is not a problem because in this region the Low Pass Filter provides high attenuation.

For each band, the 3dB bandwidth was measured. The tuning range available was also measured (from having the C1 trimmer capacitor plates fully meshed, to having them fully un-meshed). Also shown is the attenuation at the centre frequency.

80m band

3dB bandwidth: 343kHz
Insertion loss: 1.10dB at 3.520MHz centre
Tuning range: 3.320MHz to 4.03MHz

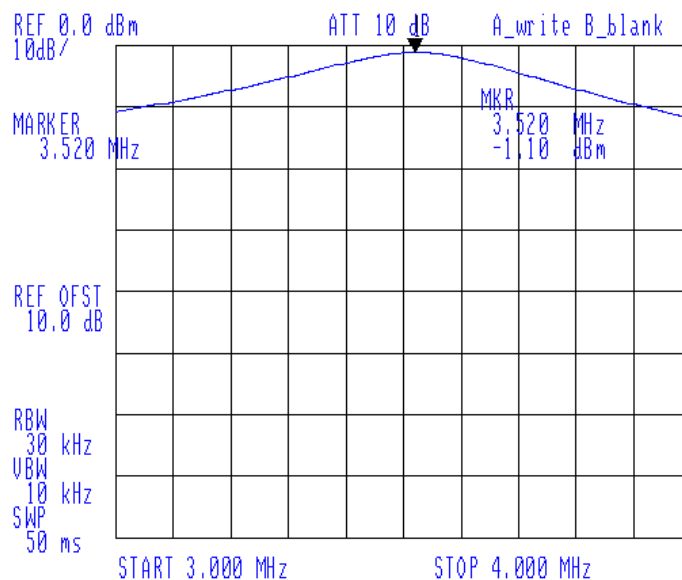
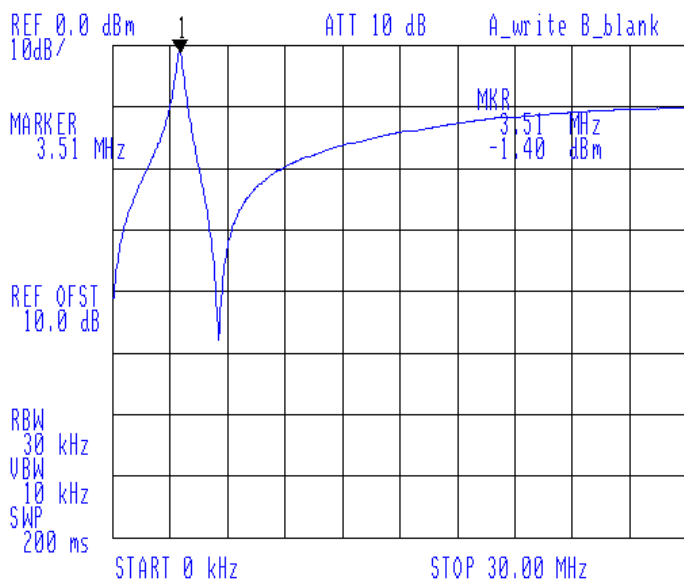

60m band

3dB bandwidth: 367kHz
Insertion loss: 1.45dB at 5.357MHz centre
Tuning range: 4.63MHz to 5.91MHz

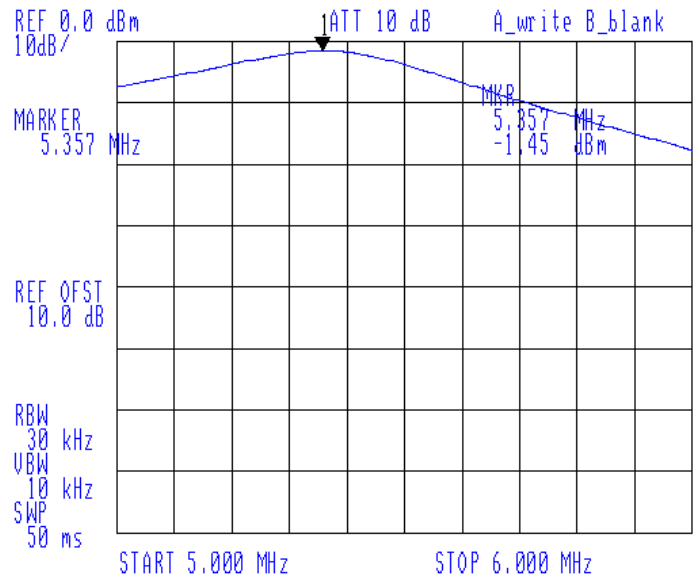
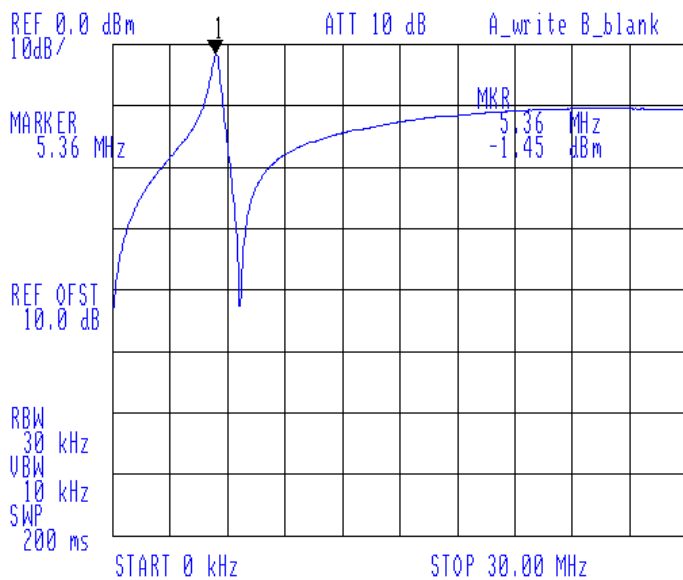

40m band

3dB bandwidth: 514kHz
Insertion loss: 1.97dB at 7.020MHz centre
Tuning range: 6.04MHz to 8.36MHz

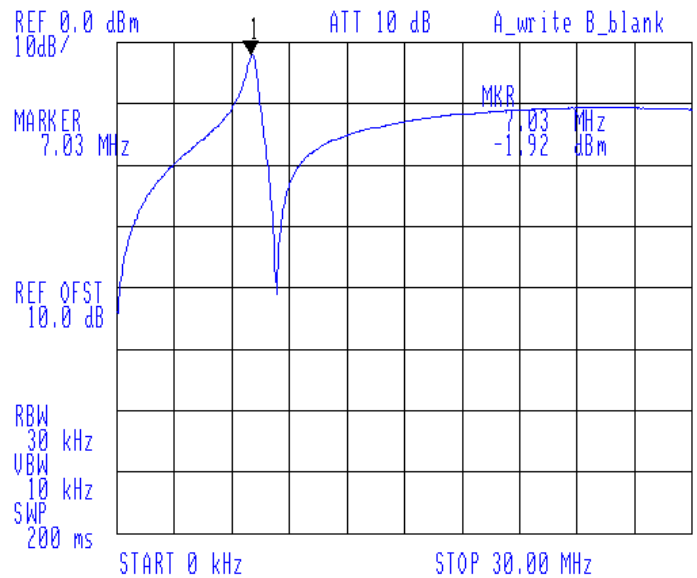
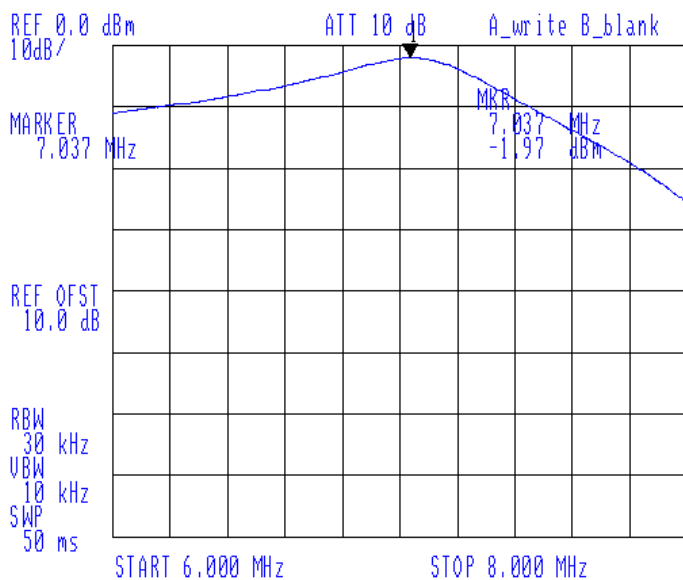

30m band

3dB bandwidth: 645kHz
Insertion loss: 2.67dB at 10.120MHz centre
Tuning range: 7.93MHz to 12.47MHz

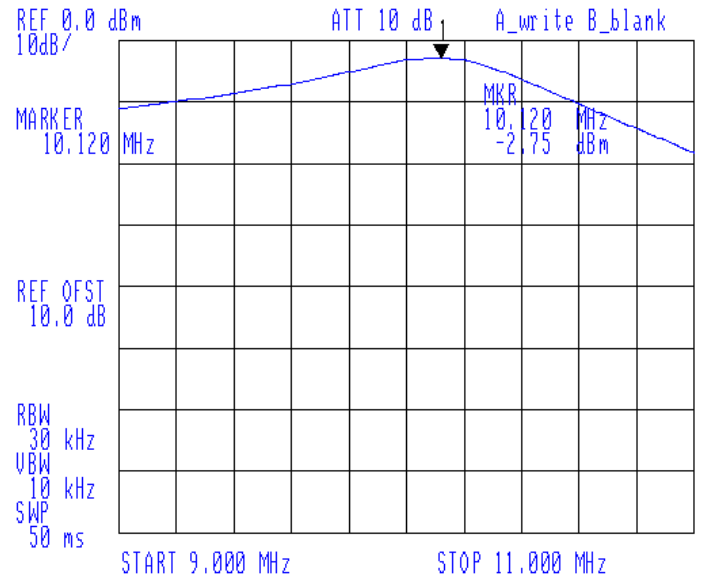
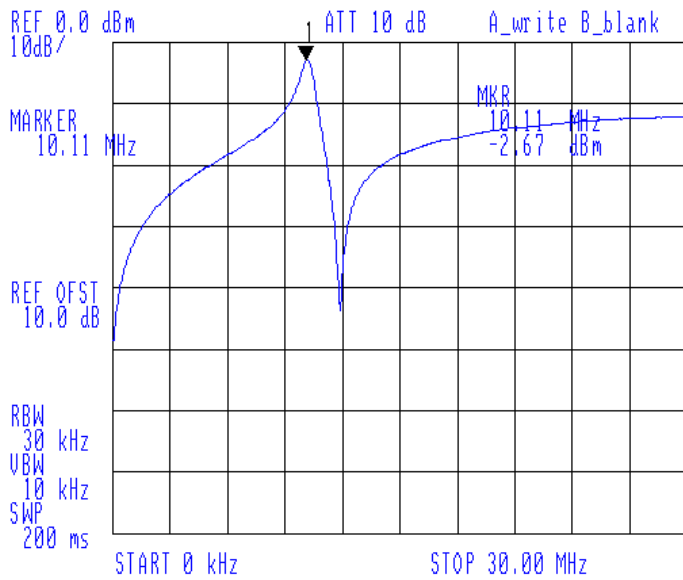

20m band

3dB bandwidth: 1,083kHz
Insertion loss: 1.30dB at 14.020MHz centre
Tuning range: 9.69MHz to 22.54MHz

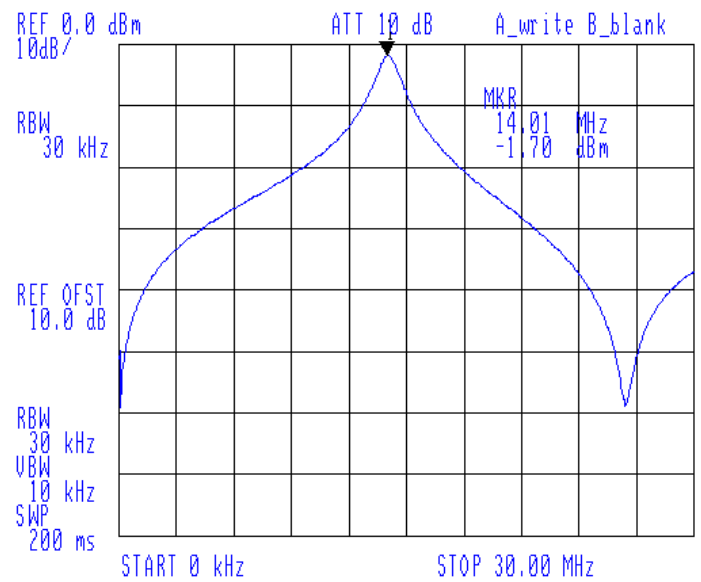
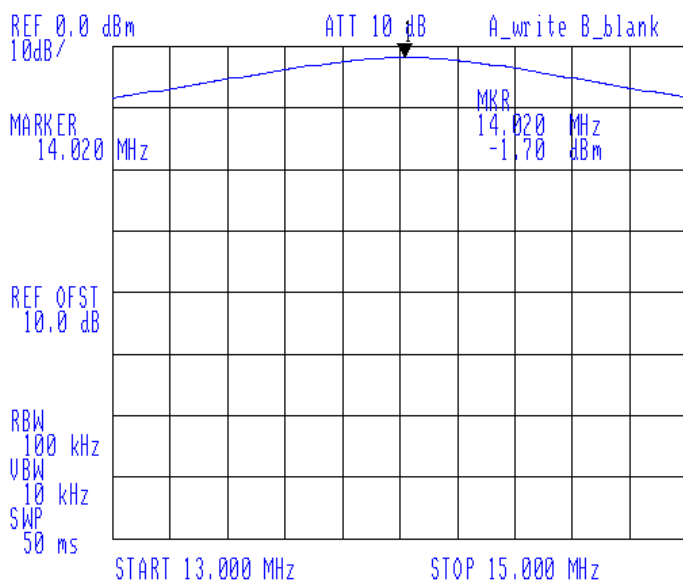

17m band

3dB bandwidth: 1,352kHz
Insertion loss: 2.77dB at 18.120MHz centre
Tuning range: 12.64MHz to 35.0MHz

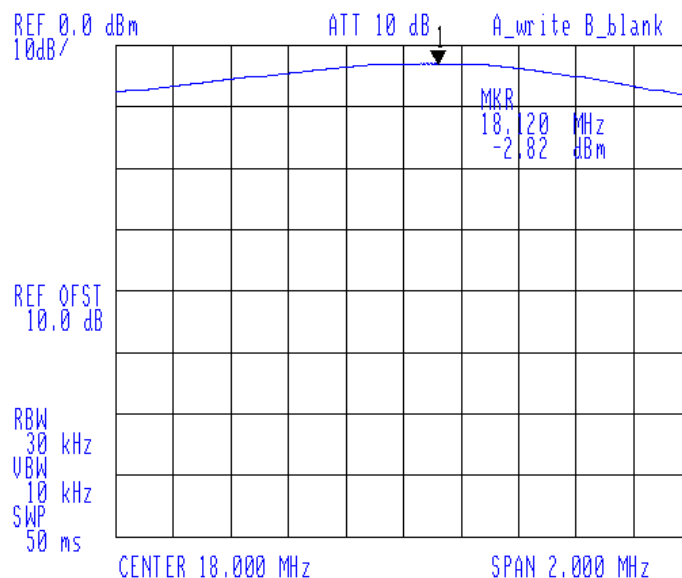
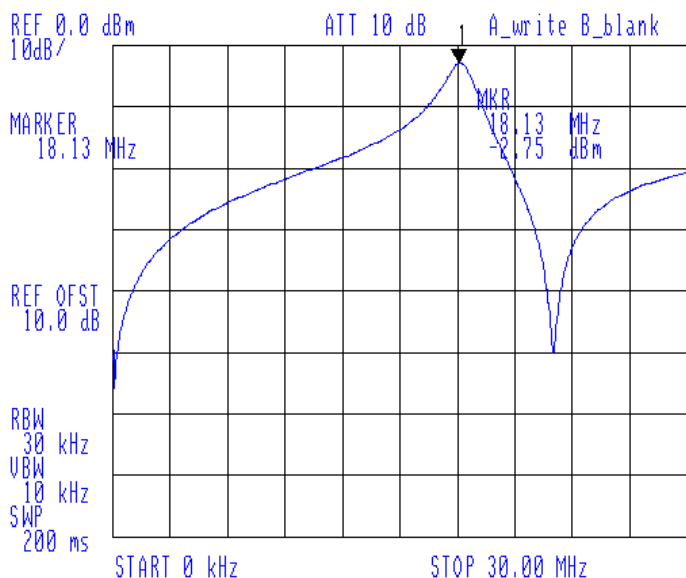

7.8 Quadrature Sampling Detector bandwidth

The following chart shows the attenuation naturally provided by the Quadrature Sampling Detector from -20kHz to +20kHz from the Local Oscillator frequency. The narrow characteristic of this circuit is an advantage because it effectively adds an additional narrow RF bandpass filter to the receiver, preventing strong nearby signals from reaching the audio amplifier stages. This improves intermodulation performance.

The circuit parameters are optimised for CW operation in this transceiver. A constructor wishing to use the I-Q outputs from IC5 to feed a computer SDR, would wish to flatten this response. To do this, reduce the values of the four 470nF capacitors C43 to C46.

QSD bandpass characteristic

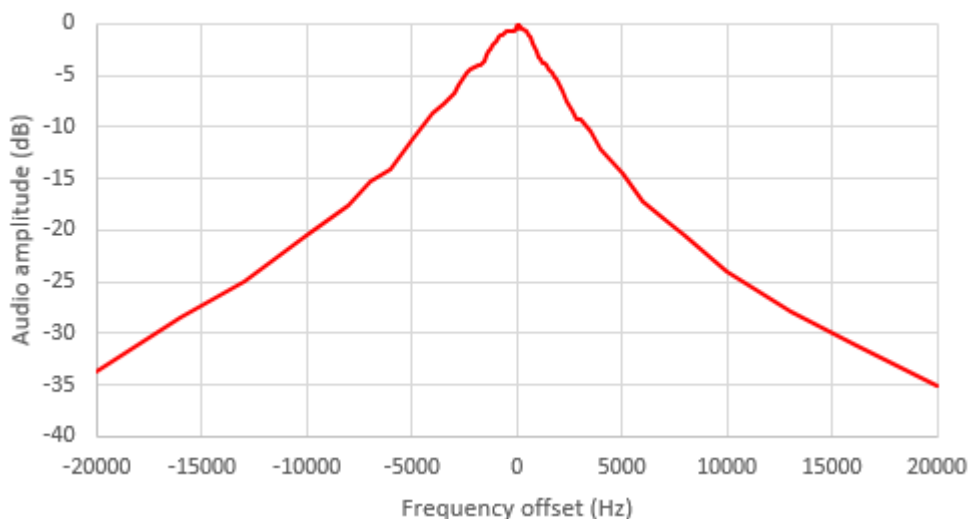

The following chart shows the Quadrature Sampling Detector roll-off over the narrower range 0 to 5kHz. You can see that at the CW operating frequency 700Hz, the attenuation is insignificant; the roll-off of the QSD does not significantly improve the selectivity of the CW filter, but it does improve the intermodulation characteristics of the receiver.

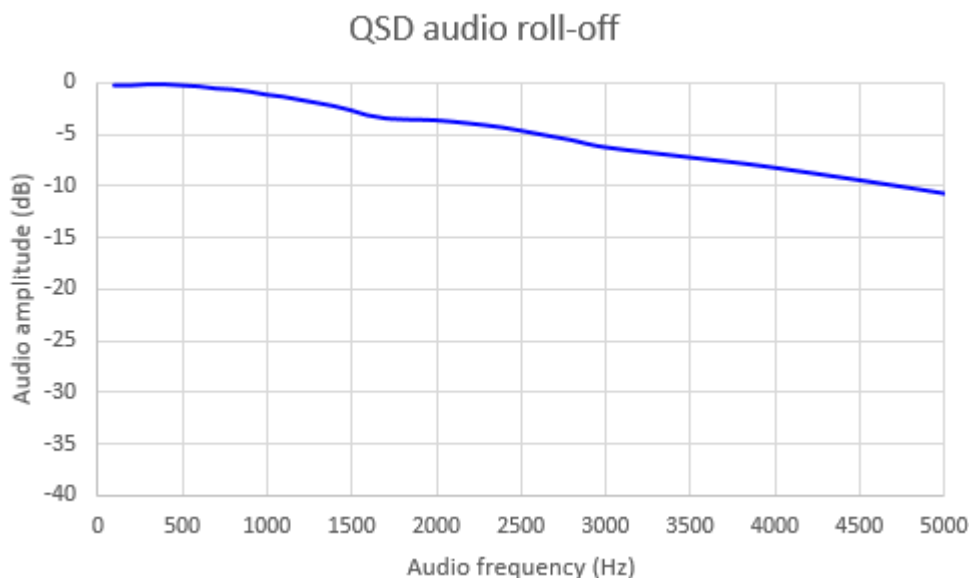

7.9 CW Filter response

This chart shows the measured response of the CW filter (combined with the other filtering in the receiver chain). It was measured by tuning the receiver across a test signal. Note that the centre frequency, a little over 700Hz, could be altered by changing some component values.

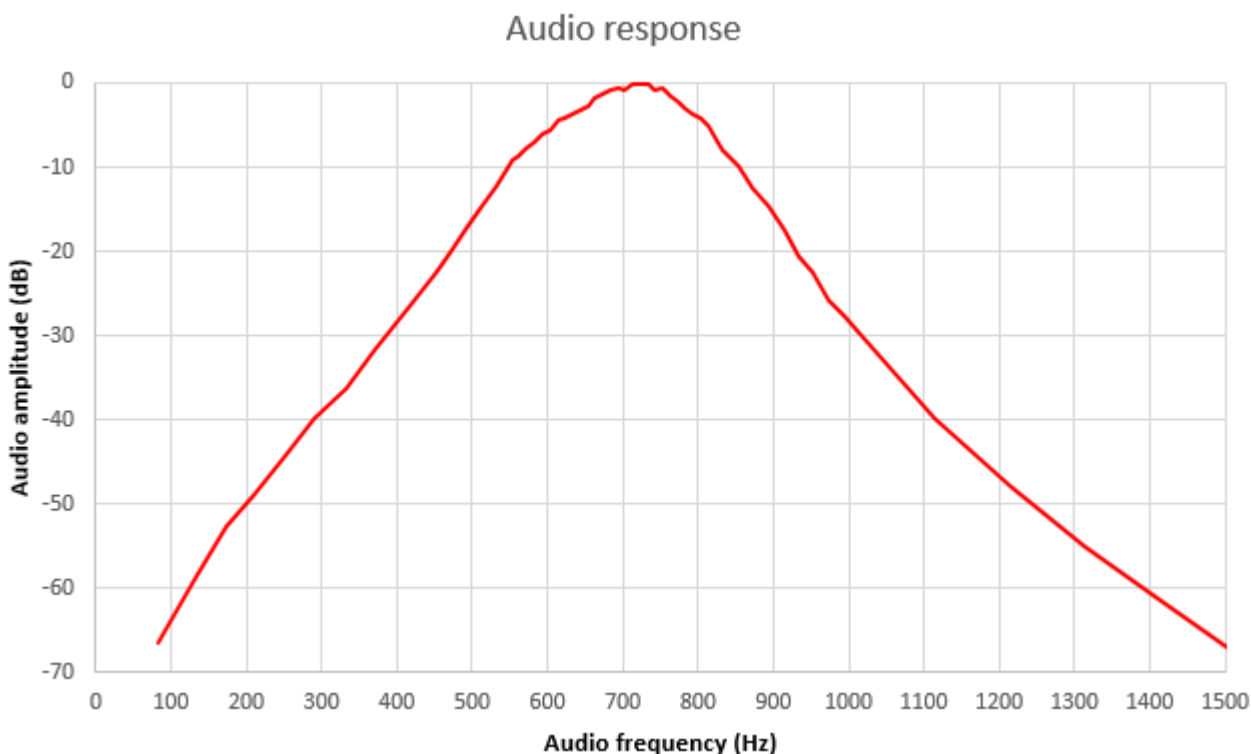

7.10 Unwanted sideband rejection

The following chart shows the measured level of the Upper Sideband signal (USB) and the unwanted Lower Sideband signal (LSB) when tuning the receiver through a strong test signal. The curves depend very heavily on the I-Q balance and audio phase shift adjustments, and these curves are from one measured prototype.

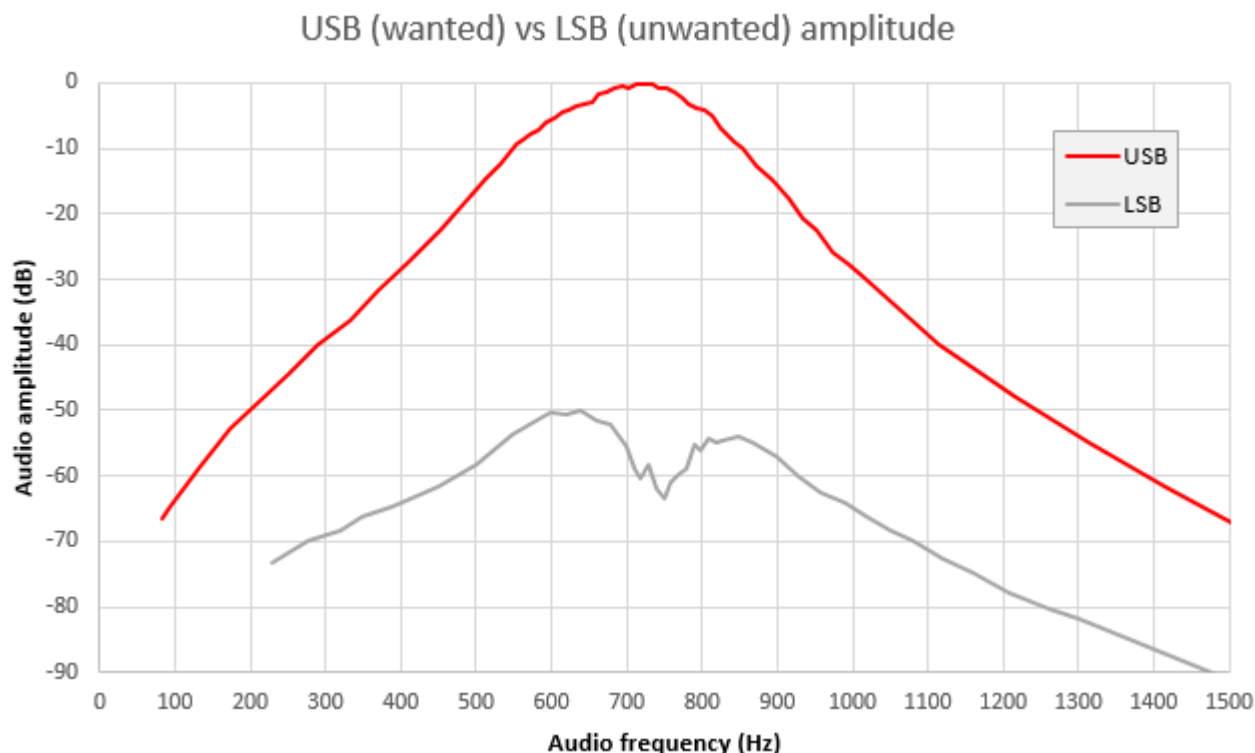

Subtraction of these two curves results in the unwanted sideband level as shown in the following chart. Normally anything above 40dB rejection is considered good; above 50dB is excellent. With the built-in adjustment features of this kit it is relatively easy to achieve really excellent unwanted sideband rejection.

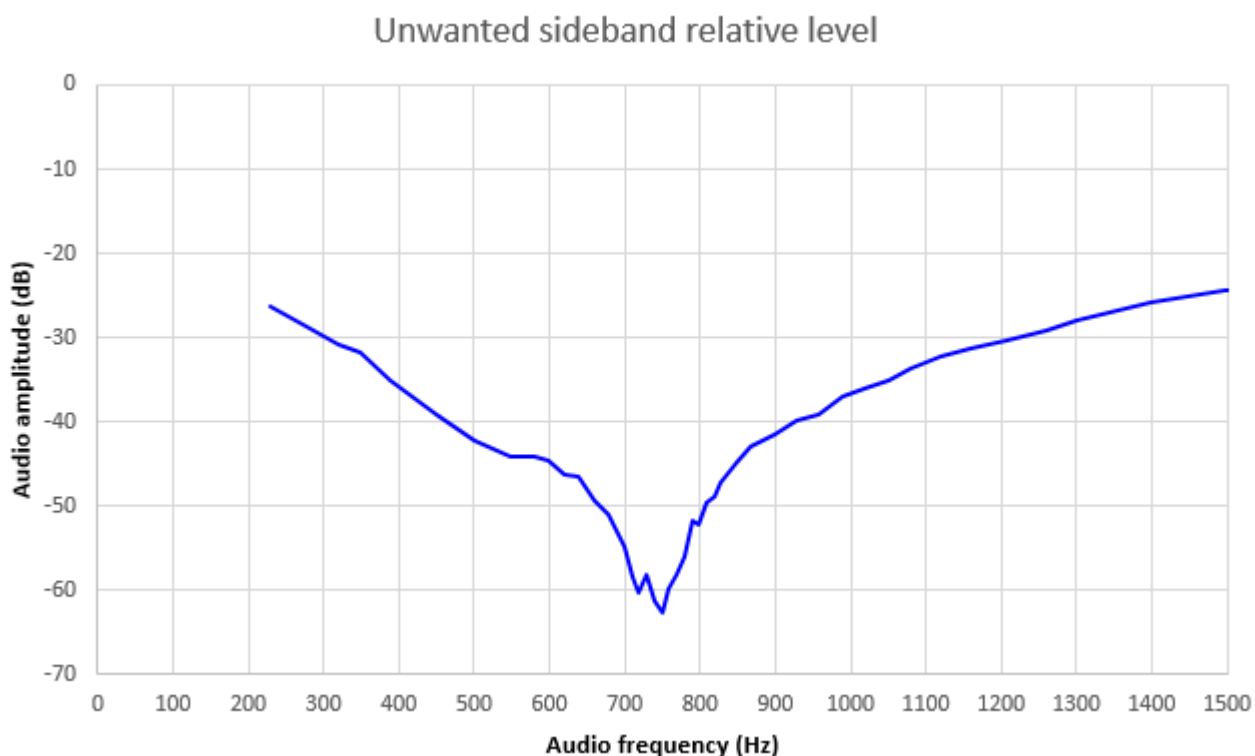

8. Resources

- For updates relating to this kit please visit the QRP Labs CW transceiver kit page <http://qrp-labs.com/qcxp>
- For any questions regarding the assembly and operation of this kit please join the QRP Labs group, see <http://qrp-labs.com/group> for details

9. Document Revision History

0.01	17-Jun-2020	First draft version for QCX+, with firmware version 1.05; created from QCX manual 1.21.
0.02	18-Jun-2020	Numerous edits based on feedback for 0.01
1.00	24-Jun-2020	First official version 1.00 – includes final edits and QCX+ photos
1.01	24-Jun-2020	Further typos
1.02	25-Jun-2020	Correction to 3.72 diagram and some further edits
1.03	05-Aug-2020	Corrected colour code of R46 in step 3.59 Corrected T1 instructions step 15, which should read hole 1 (not 2) Correction to step 3.56, which referred to R46 but should be R65 Parts list on page 7 said 680pF caps for 30m: should be 560pF IC11 (7805) was missing from the parts list on page 8 T1 step 7 “loop on the third” should be “loop on the fifth” Added clarification about the 2x3-pin MALE header in section 3.46 Additional text in step 1 in section 3.72 Corrected typo in final paragraph of 5.4 (change “receive” to “transmit”)
1.04	02-Nov-2020	3.74: added note about TWO peaks per rotation 3.60: Added that higher iron temperature may be useful for the headers Split operating instructions out into a separate document 3.66: Change to use connection of three wires from PCB to gain pot\
1.05	23-Jul-2021	Cheat sheet removed (it is up to date in the operating manual) Amended manual for PCB Rev 3, specifically the tip and ring of the 5V/ PTT jack are swapped, to be consistent with the 50W PA
1.06	27-Nov-2021	Added instructions for 160m QCX+
1.07	14-Feb-2022	Amended 160m instructions – now use standard 27Mhz crystal or 25MHz TCXO, in firmware 1.09
1.08	15-Feb-2022	Amended for QCX+ PCB Rev 4
1.09	06-Mar-2022	Fixed diagram error in section 3.38
1.10	28-Jul-2022	Amended for kits produced from July 2022 onward; R42 is now 820-ohm, IC5 LM4562 and IC6-10 are NE5532.
1.11	14-Mar-2023	Added note to switch off AGC before doing alignments (or set it to minimum sensitivity).

- 1.12 29-Oct-2025 Removed sections about 6mm nylon screws which are no longer required.
- 1.13 12-Dec-2025 Correct section 3.22, about the 27 MHz crystal
- 1.14 03-May-2026 A few minor corrections and edits based on feedback