

Ultimate LPF kit: Relay-switched LPF kit

PCB Revision 2

1. Introduction

Thank you for purchasing the QRP Labs relay-switched low-pass filter (LPF) kit.

This kit is designed to compliment the Ultimate3 QRSS/WSPR kit but could also be used on its own at the output of a homebrew QRP transmitter. The kit consists of a PCB that switches one of five LPF's between the transmitter output and the antenna (the kit's "RF output"). This kit does not include the LPF's, it is designed to accept the plug-in LPF filter kit, which is available separately (for bands 2200m, 600m, and ten HF bands 160m – 10m).

Note that when used with the Ultimate3 QRSS/WSPR kit, the relay-switched LPF kit provides up to six bands, each with its own relay-switched LPF. This is because the Ultimate3 kit contains space on its PCB for fitting Relay 0 (band 0). Combined with the 5 LPF's on the relay-switched LPF kit PCB (band 1 to 5) this allows for six LPF's.

2. Design

The circuit diagram of one of the LPF switching sections is shown to the right (band 1). This circuit is simply repeated five times over, on the relay-switched LPF kit PCB (bands 1 to 5). The same circuit also exists once on the Ultimate3 QRSS/WSPR kit board (band 0). Together, they provide six selectable bands for the Ultimate3 QRSS/WSPR kit.

The relay is a DPDT type (dual pole, dual throw). When the relay is un-energised, the resting position is for both input and output of the corresponding LPF to be shorted to ground. An LPF kit is plugged in to the two 4-way sockets, shown here as SV3 and SV4.

When the relay is energised, the corresponding LPF is switched into the circuit, connected between RF In and RF Out. In use, only one relay should be energised at once time, to switch in the desired LPF.

The relays are miniature Panasonic RX2-5V types. With a height of only 8.5mm, they are small enough to fit underneath the plug-in LPF boards. The coil current is only 28mA and it can therefore be driven directly by an AVR microcontroller output pin. A 1N4148 diode is installed across the coil of each relay, to prevent high switching voltages from damaging the microcontroller output.

The relay-switched LPF kit can be used in your homebrew QRP transceiver project too. One side of the relay coils are connected to +5V. So to switch a relay, the appropriate band 1 to 5 input should be driven to a low voltage to energise the relay coil. A transistor could also be used to switch each relay coil.

When used with the Ultimate3 QRSS/WSPR kit, you can either take the RF output from the original connections on the Ultimate3 PCB, or from connections provided on the relay-switched LPF board.

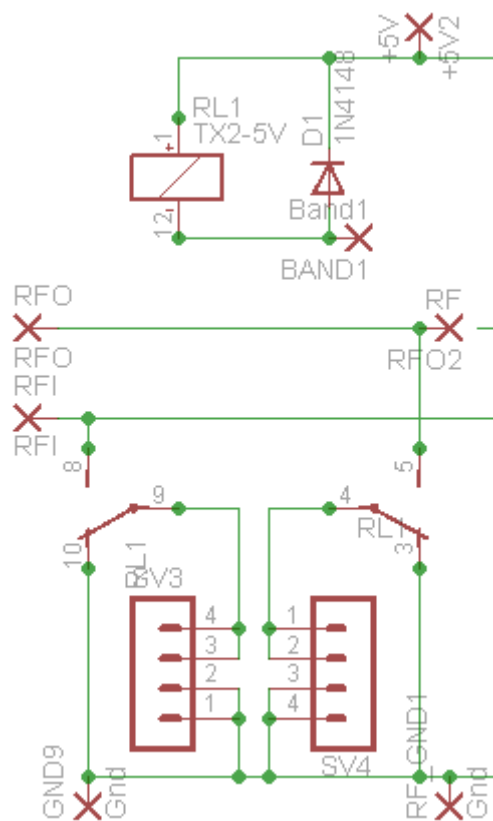

Note that the Rev 2 PCB allows the output side of each LPF / relay-switch to be connected either to the common RF Output signal, or to individual connection pads. In this way, you can use either a single antenna, or connect different antennas for each band. The choice is arranged by wire jumpers, described below.

3. Parts List

- RL1-RL5 Panasonic TX2-5V relays. Six are supplied (five are installed on the LPF kit PCB, one is provided for the installation on the Ultimate3 kit PCB)
- D1-D5 1N4148 diode. Six are supplied (five are installed on the LPF kit PCB, one is provided for the installation on the Ultimate3 kit PCB)
- 10 of 4-way female header sockets
- 1 of 10-way (2 x 5) female header socket
- 1 of 10-way (2 x 5) male header plug, extended (tall) size
- 4 of 25mm nylon hex spacers
- 1 of Printed circuit board, 80 x 37mm size

4. Construction

Please refer to the parts placement diagram below.

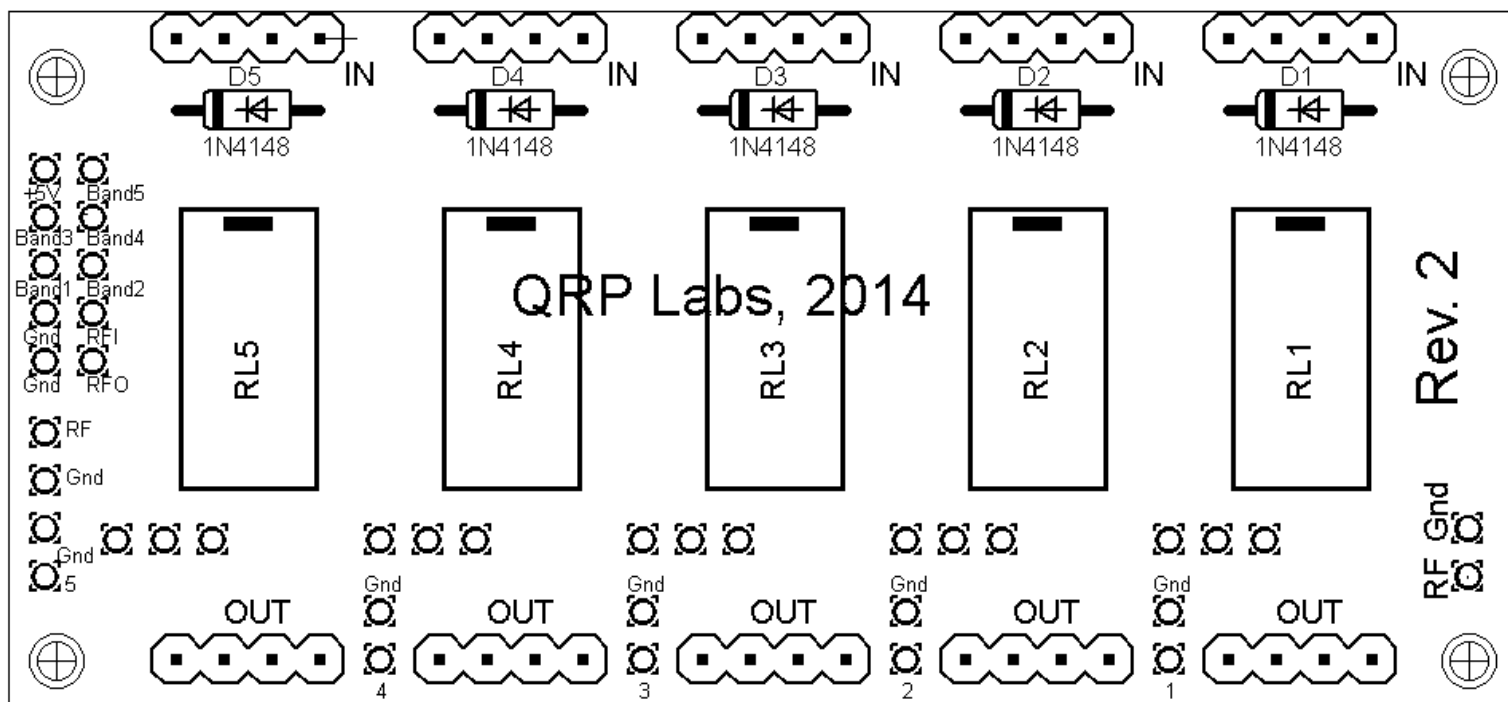

The order of construction is not important but a good principle to follow is to install the smaller components first, so that the larger ones do not prevent easy access.

The following photographs show PCB Rev 1; the Rev 2 PCB is the same but has additional jumper pads to facilitate the use of multiple antennas if required (described below). The Rev 2 PCB also has silk-screen text labels “IN” and “OUT” to ensure that you plug in the low pass filter modules with the correct orientation.

One suggested order of construction is described in the following sections.

1) Solder in the five diodes D1-D5. Pay attention to align the diodes correctly, according to the stripe on the diode and the silk-screen of the PCB.

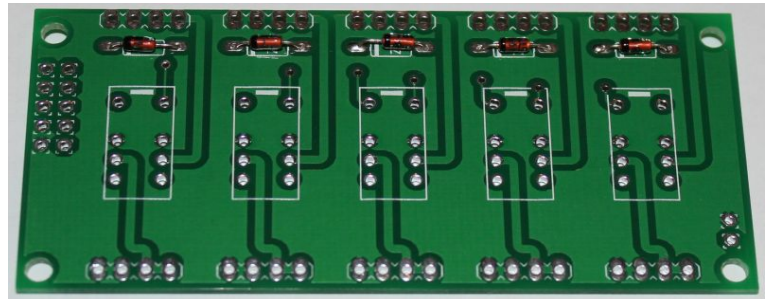

2) Connect jumpers at each of the five relay locations on the board, to connect the LPF output either to the common RF output, or the individual output for separate band antennas.

You can use the offcuts from the diodes. I recommend the jumpers at this stage, while they are still easily accessible, and not yet crowded by installed relays and 4-way sockets. Another suggestion is to use a small loop, perhaps 5mm high, rather than lay the jumper wire flat near the board. The small loop will make the wire easier to change later, if you need to. [Please see the section below describing these jumper options.](#)

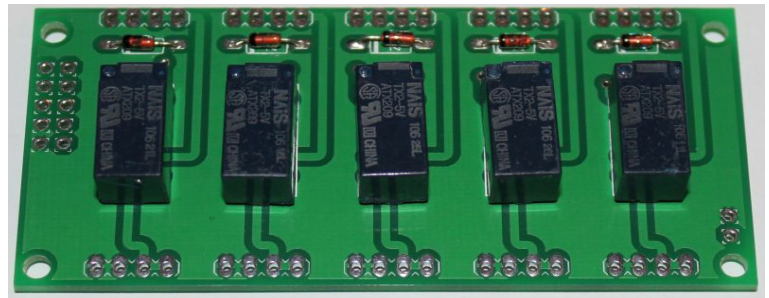

3) Fit and solder the five relays. Ensure that the relay pins are straightened before inserting into the PCB, as some may have become slightly bent.

4) Fit and solder the ten 4-way sockets for the LPF's. Ensure that they are pushed in properly into the PCB, and at right-angles to the PCB. One way to do this, is to plug in a constructed LPF to ensure correct orientation of the sockets, then solder them to the PCB.

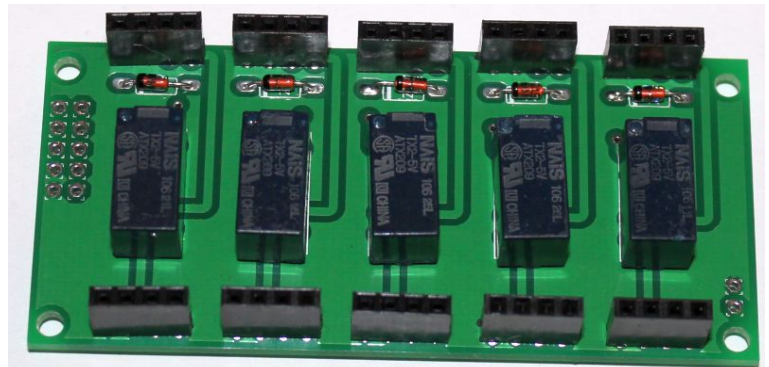

Note that you should aim for more careful and straight alignment than the slightly crooked result shown here. It works, but is not pretty.

5) If using the LPF board with the Ultimate3 QRSS/WSPR kit, solder the 6'th diode and relay (for band 0) in place under the plug-in LPF on the main Ultimate3 PCB. Note that if you have previously fitted wire jumpers at W0-W1 and W2-W3 on the main Ultimate3 PCB (for standalone use WITHOUT the relay-switched LPF board), then you need to remove these wire jumpers now.

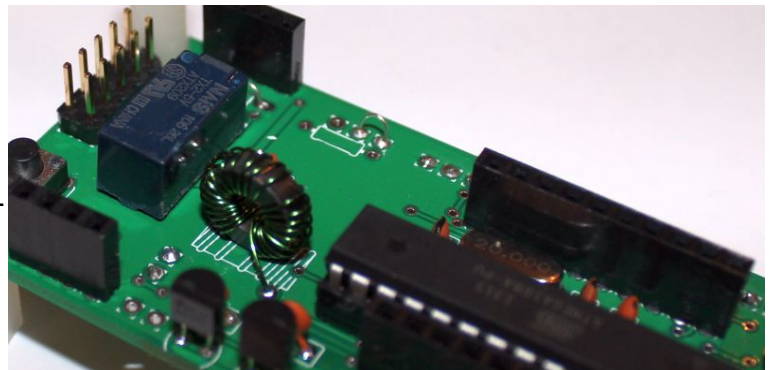

6) Fit the tall 10-way (5 x 2) pin header connector, pictured to the right, to the Ultimate3 PCB. The board photo (above right) shows the old (pre 6-Feb-2014 shipped kits) board interconnect method, using the standard-height header. Insert the tall header (right), with the short pins into the PCB, and the tall pins sticking up next to the relay.

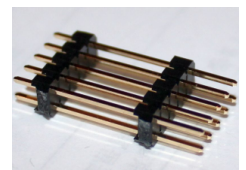

Fit the 10-way (5 x 2) socket to the bottom side of the relay kit PCB (tracks side, not the components side). This will mate with the long pins of the tall header fitted to the U3 PCB.

The easiest way to ensure that the plug and socket are perfectly aligned is to assemble the U3 and the relay PCB in their final configuration, bolting the PCB's together using the 25-mm hex spacers, but WITHOUT soldering yet. This will ensure correct orientation of all the connectors.

On the Ultimate3 PCB revision 1, the 25-mm hex spacers are a rather tight fit with some of the components on the U3 PCB. I suggest temporarily removing the LCD from the U3, then hold the 25-mm hex spacers fixed in place, while turning the shorter 12-mm hex spacers to tighten them into the 25-mm spacer screw thread. This way you avoid trying to turn the 25-mm spacers which are very close-fitting against the components on the U3 PCB (revision 1).

The U3 revision 2 PCB is a less tight fit, so this may not be needed. However it will still help to temporarily remove the LCD from the U3, so that you can access the U3-side header with your soldering iron.

When the two boards are bolted together and the connectors perfectly aligned, you can solder the 10-way connectors.

Connection of wire jumpers

Please refer to the diagram below.

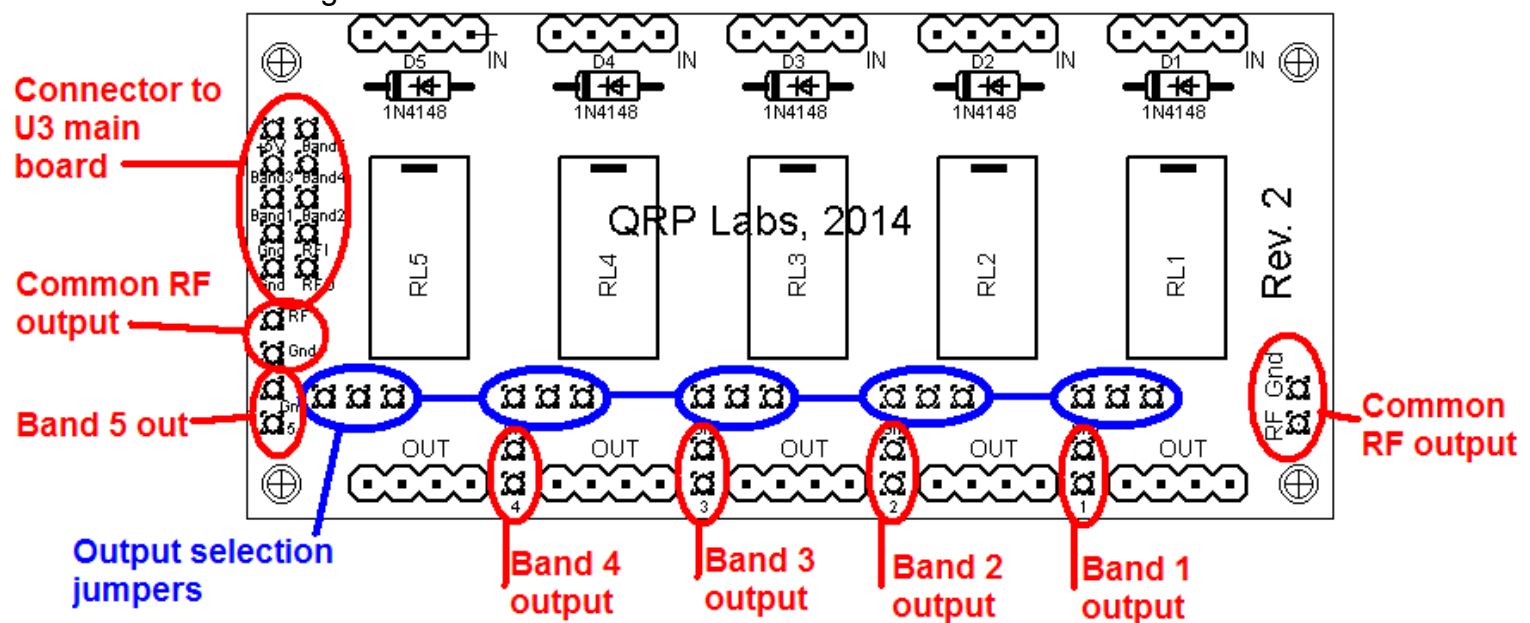

The common RF output is available at the left and right sides of the board. It is also connected to the Band 0 output, the output of the Band 0 relay on the main U3 board. Separate outputs Band 1 to Band 5 are indicated on the diagram. The output of each relay can be connected either to the common RF output, or to the corresponding individual band output.

The selection of common RF out or the individual band output is achieved with jumper wires, in the blue circled areas in the above diagram. The centre connection should be wired to either the right (for common RF out) or the left (for individual band output). The example diagrams to the right illustrate the connections for each case, for Band 4.

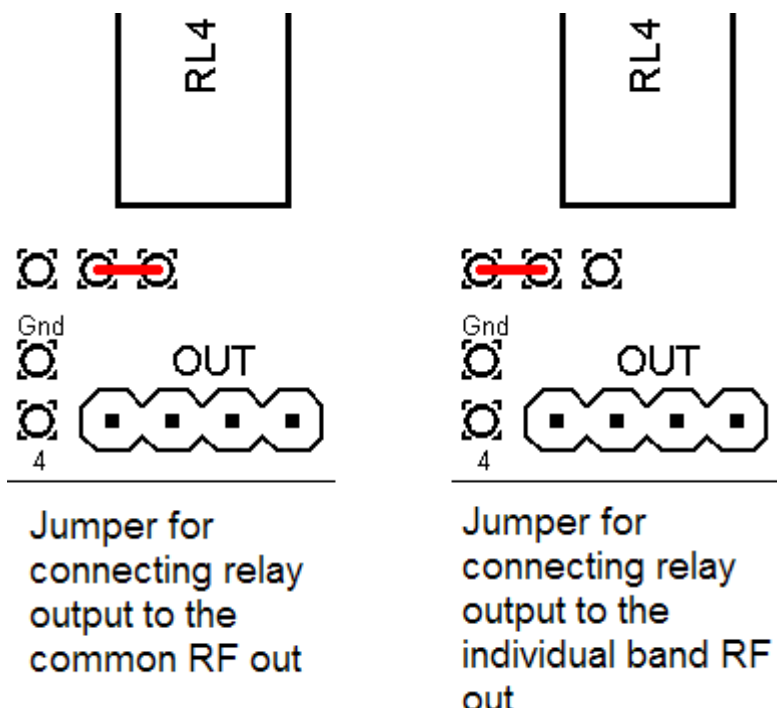

For the simple case, matching the earlier PCB revision 1, when all relay outputs are connected to the same common antenna (the common RF Out), jumper all the central pads of each three, to the pad to its right. This is shown in the left diagram, above.

5. Operation

When used with the Ultimate3 kit, firmware version v3.02 or above is required. Please refer to the appropriate operation manual for your firmware version, for details.

6. Resources

Please see the kit page <http://www.hanssummers.com/ultimatepf> for information on latest updates and issues.

Please join the Yahoo forum <http://groups.yahoo.com/neo/groups/QRPLabs/info> for discussion and updates on all the kits!

7. Version History

1 14-Jan-2014

- Initial version

2 06-Feb-2014

- Modified PCB interconnection method, to use single tall-header plug on the U3 side, and single 10-way socket on the relay board side.

3 28-Mar-2014

- PCB Rev 2: adds the jumper wire connections to allow connection of each relay output to either the common RF output, or an individual band output pad.

4 16-Feb-2015

- Added page numbering