

QDX: QRP Labs Digital Xcvr (transceiver)

Assembly, design and performance manual

--- PCB Rev 5 ---

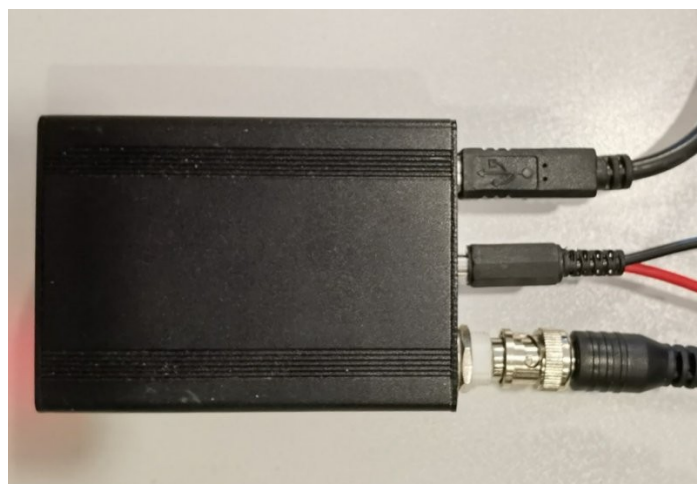
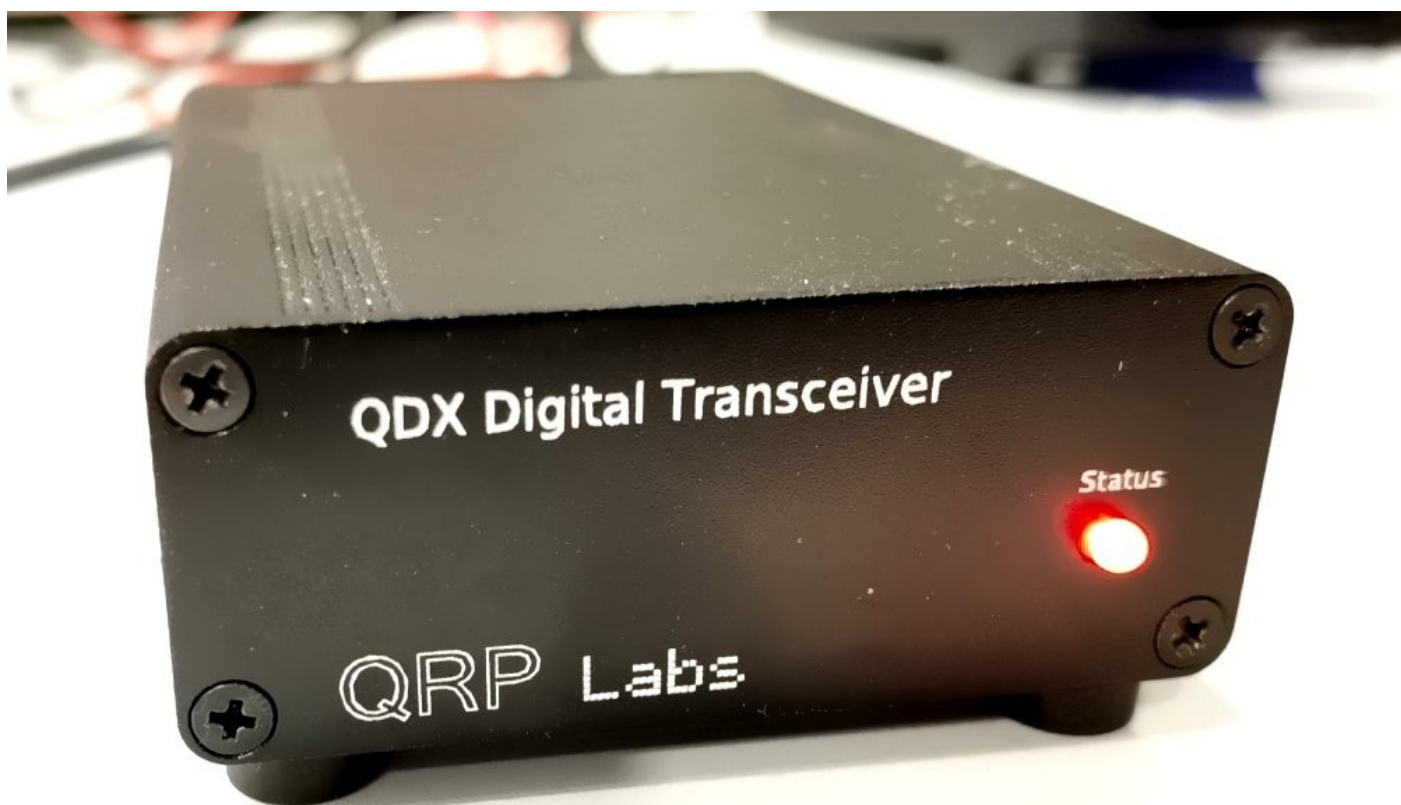

Contents

Contents.....	2
1. Introduction.....	3
2. Assembly.....	5
2.1 General guidelines.....	5
2.2 Parts list.....	9
2.3 Inventory parts.....	13
2.4 Install all the ceramic capacitors.....	14
2.5 Install 1N4007 diodes.....	16
2.6 Install 47uH inductors.....	17
2.7 Install PA transistors.....	18
2.8 Assemble and install transformer T1.....	19
2.9 Prepare and install tapped inductor L12.....	22
2.10 Wind and install L14.....	28
2.11 Install Low Pass Filter toroids.....	29
2.12 Wind and install trifilar toroid T2.....	32
2.13 Install the 3mm red status LED.....	35
2.14 Install jumper wire.....	36
2.15 Install connectors.....	37
2.16 Optional enclosure.....	38
3 Design.....	40
3.1 Summary.....	40
3.2 Block Diagram.....	43
3.3 Synthesized local oscillator.....	44
3.4 Solid state transmit/receive switch.....	48
3.5 Switched receiver band pass filter.....	49
3.6 Double-balanced Quadrature Sampling Detector.....	50
3.7 Low noise balanced differential pre-amplifiers.....	51
3.8 Analog to Digital Converter.....	52
3.9 Embedded Software Defined Radio.....	53
3.10 Embedded 24-bit 48ksps stereo USB Sound card.....	56
3.11 CAT control serial interface.....	57
3.12 Audio frequency analysis.....	57
3.13 Class-D Push-pull Power amplifier.....	67
3.14 Switched output Low Pass Filters.....	68
3.15 Configurable PTT (Push To Talk) output.....	86
3.16 Voltage regulation and supply decoupling.....	87
4 Performance measurements.....	88
4.1 Receive current consumption.....	88
4.2 Transmit current consumption.....	88
4.3 Power output vs supply voltage.....	89
4.4 Output harmonic content.....	90
4.5 Unwanted sideband suppression.....	91
5. Resources.....	92
6. Document Revision History.....	92

1. Introduction

The QDX is a high performance, five-band 5W Digital modes transceiver with CAT control and built-in USB sound card. QRP Labs presents QDX, a digital transceiver with a ratio of performance to price not available until now.

- Versions: 80, 60, 40, 30 and 20m OR 20, 17, 15, 12, 11 and 10m; 5 W from 9 – 10V supply
- Clean single signal output (zero residual carrier, zero unwanted sideband)
- Solid state PIN-diode switched Low Pass Filters and solid state Band Pass Filters
- Solid state transmit/receive switching
- High performance embedded-SDR SSB receiver using 112dB 24-bit stereo ADC chip
- Built-in USB sound card: 48ksps 24-bit stereo
- Built in USB Virtual COM port serial for CAT control
- Si5351A Synthesized local oscillator with better than 0.001Hz resolution and high precision 25MHz TCXO reference as standard
- Built-in signal generator
- Built-in suite of configuration and analysis tools
- Lifetime free firmware upgrades with QRP Labs Firmware Update (QFU) bootloader for easy firmware update on any OS with no extra software, or drivers, or programming hardware
- All SMD components pre-installed by factory, only through-hole component soldering by the kit constructor
- Receive current: 150mA; Transmit current 1.0 – 1.1A (9V supply, 5W output)
- Only four connectors: USB (audio and serial for CAT), Power, PTT (external amp) and RF
- Optional smart aluminium extruded enclosure measuring just 89 x 63 x 25mm

No test equipment is required to build, align and operate this digi modes transceiver. There are no alignment tasks.

We hope you enjoy building and operating this kit! Please read this manual carefully, and follow the instructions step by step in the recommended order. Later in the manual the circuit design is described in detail and we recommend reading and understanding this section too, to get the maximum enjoyment and education from your new radio.

Typical performance measurements are shown in the measurements section.

The operating manual is a separate document and will get you started with QDX and your WSJT-X or other digi modes software in minutes.

PLEASE READ THE BASIC ASSEMBLY AND USE INSTRUCTIONS IN THIS MANUAL VERY CAREFULLY BEFORE APPLYING POWER TO THE BOARD!

Additional connections:

The Rev 5 PCB has additional pin header pads on the top right corner of the PCB (as pictured) which provide access to the VGA monitor and PS/2 keyboard ports, and serial port #2. The PTT connection can be re-purposed as serial port #3. Details of these functions are in the operating manual. They're just easier to access now on the Rev 5 PCB than on earlier PCB revisions.

IMPORTANT!

QDX can be built for 9V or 12V operation! You need to decide NOW!

A 9V QDX produces 5 W power output from a supply voltage of 9V or a little over. At 12V, a QDX built for 9V could be producing 8 W power output which is likely to cause over-heating and perhaps failure of the BS170 final transistors. Do not power a QDX with a higher voltage than you built it for.

Operation of QDX at more than 6W power output is NOT RECOMMENDED.

If you wish to operate using a 12 V supply, you may use a two turn secondary winding on the output transformer T1, so a 3:2 ratio instead of the 3:3 turns ratio documented in this manual. Remember this when you come to the assembly step for preparing and installing the output transformer T1. The “primary” is still 3 turns, with a tap half way at 1.5 turns. The secondary (no tap) will now be only two turns.

The chart below shows the measured power output vs supply voltage for the standard 3:3 winding (Red line); at 12 V supply the output power of around 8 W is too high and likely to cause over-heating or failure of the power amplifier transistors. If you wish to use a supply of 12 - 13 V the 3:2 winding style is more suitable and will produce 4 – 5 W output for 12 – 13 V supply. The graph shows 40m but other bands are very similar.

Operation at more than 12V will reduce the protection safety margin available in the event of very long key-downs, hot environment, antenna mismatch, cable faults etc. I don't recommend more than 12V. It isn't worth pushing more just for a fraction of a dB. It is acceptable to use diodes in series on the power line, each one will drop the voltage 0.6V or so. Beware that a 12V nominal batter will potentially be several volts higher when fully charged.

40m power output vs Voltage, transformer windings

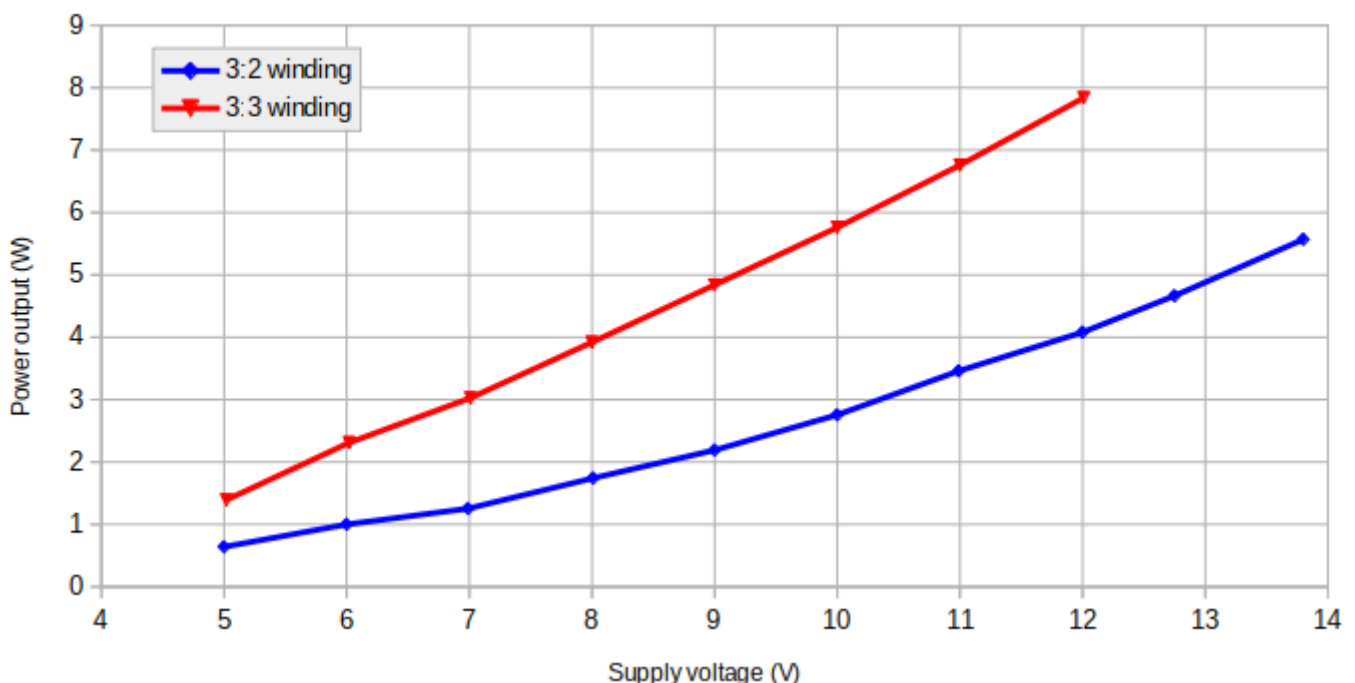

2. Assembly

2.1 General guidelines

Assembly of this kit is quite straightforward, most components are SMD and have already been pre-assembled by the PCB factory. The usual kit-building recommendations apply: work in a well-lit area, with peace and quiet to concentrate. **Some of the other semiconductors in the kit are sensitive to static discharge. Therefore, observe Electrostatic discharge (ESD) precautions.**

And I say it again: **FOLLOW THE INSTRUCTIONS!!**
Don't try to be a hero and do it without instructions!

A jeweler's loupe is really useful for inspecting small components and soldered joints. You'll need a fine-tipped soldering iron too. It is good to get into the habit of inspecting every joint with the magnifying glass or jeweler's loupe (like this one I use), right after soldering. This way you can easily identify any dry joints or solder bridges, before they become a problem later on when you are trying to test the project.



You could also take photos with a mobile phone, and use the phone's zoom features to view the board in detail.

Triple check every component value and location BEFORE soldering the component!

It is easy to put component leads into the wrong holes, so check, check and check again! It is difficult to de-solder and replace components, so it is much better to get them correctly installed the first time. In the event of a mistake, it is always best to detect and correct any errors as early as possible (immediately after soldering the incorrect component). Again, a reminder: removing a component and re-installing it later is often very difficult!

Please refer to the layout diagram and PCB tracks diagrams below, and follow the steps carefully.

Use of a good quality soldering iron and solder is highly recommended for best results!

The following diagrams show the PCB layout and track diagrams of the QDX.

Tracks shown in BLUE are on the bottom layer. Tracks shown in RED are on the top layer. There are only two layers (nothing is hidden in the middle). Not shown in this diagram are the extensive ground-planes, on both sides of the board. Practically everything on both layers that isn't a RED or BLUE track, is ground-plane! The two ground-planes are connected at frequent intervals (not more than 0.1-inches) by vias.

NOTE: the capacitor lead spacing on the PCB is 0.1-inches (2.54 mm) and most of the capacitors are sized appropriately for this. From time to time, due to availability constraints, we may have to use capacitors with 0.2-inch lead spacing (5.08 mm); this is not a mistake, it is just due to component availability. In this case simply use a pair of long-nosed pliers (etc) to straighten out the wires and make them spaced for the 0.1-inch pads.

NOTE: PCB Rev 3a is different from Rev 3 only in that the trifilar transformer T2 was moved slightly further from the PCB edge, and some components nearby were moved slightly too. **Rev 3a has a short-circuit from a via to ground, which must be resolved – see section 2.3a below.**

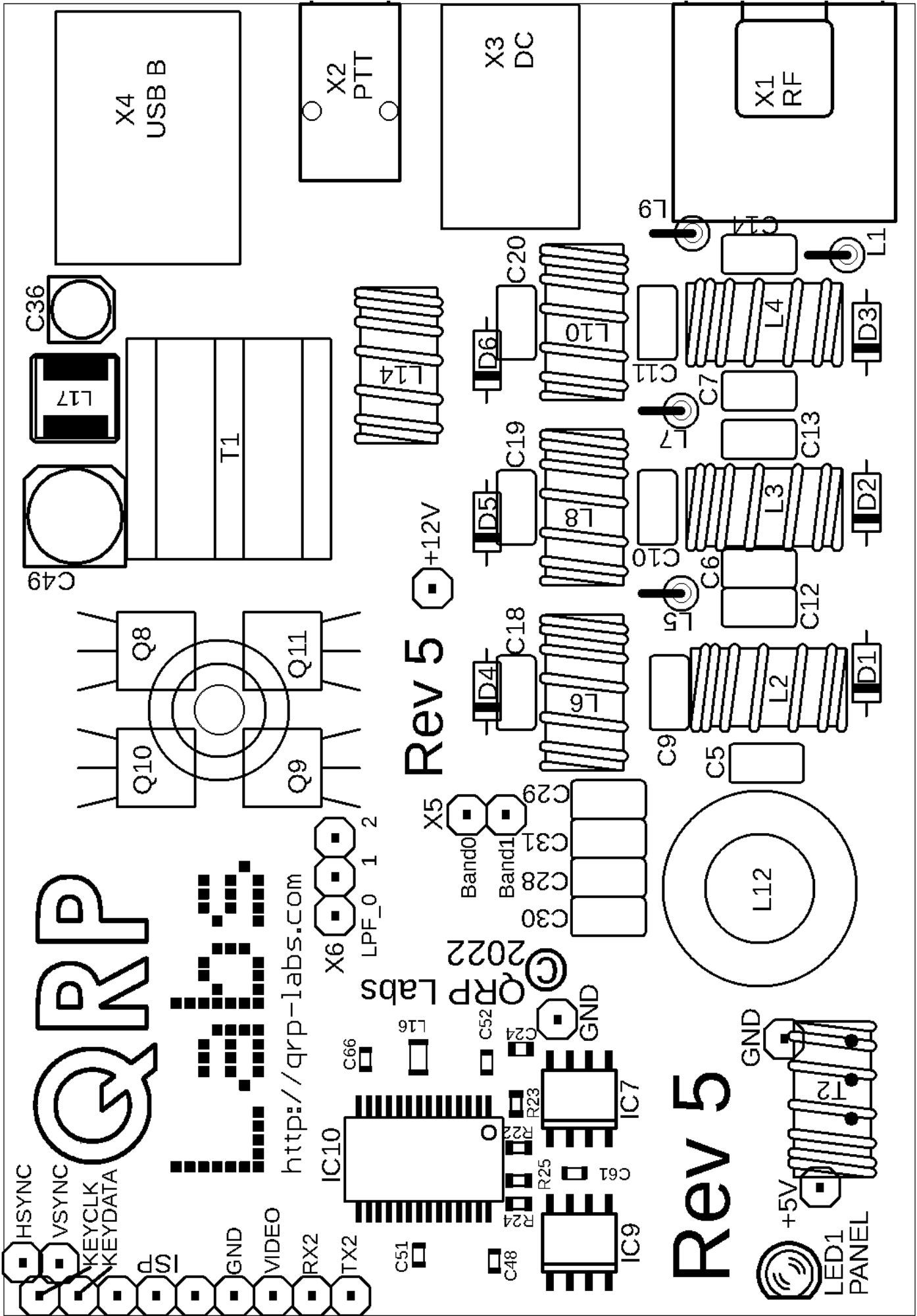

© QRP Labs, 2022

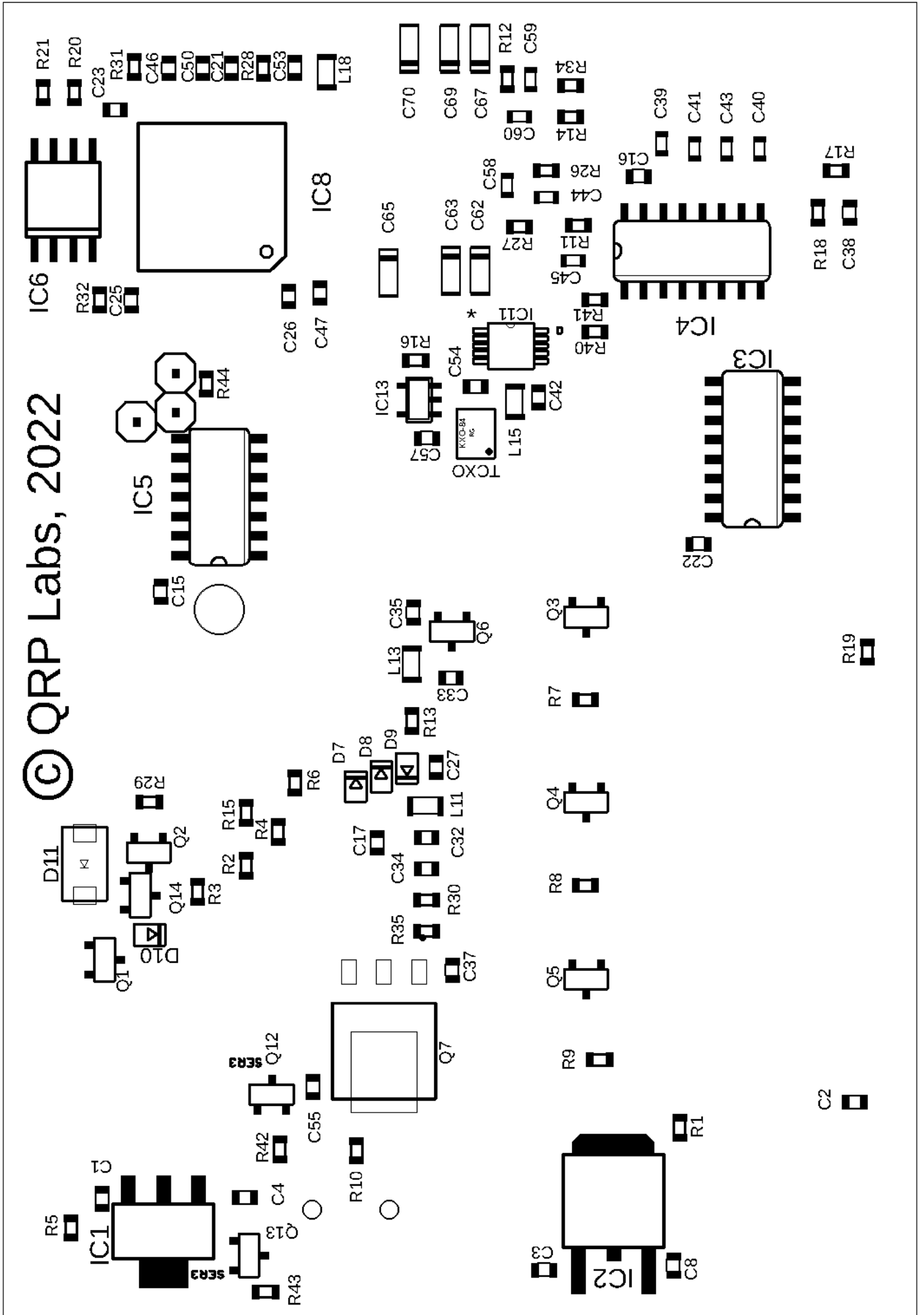

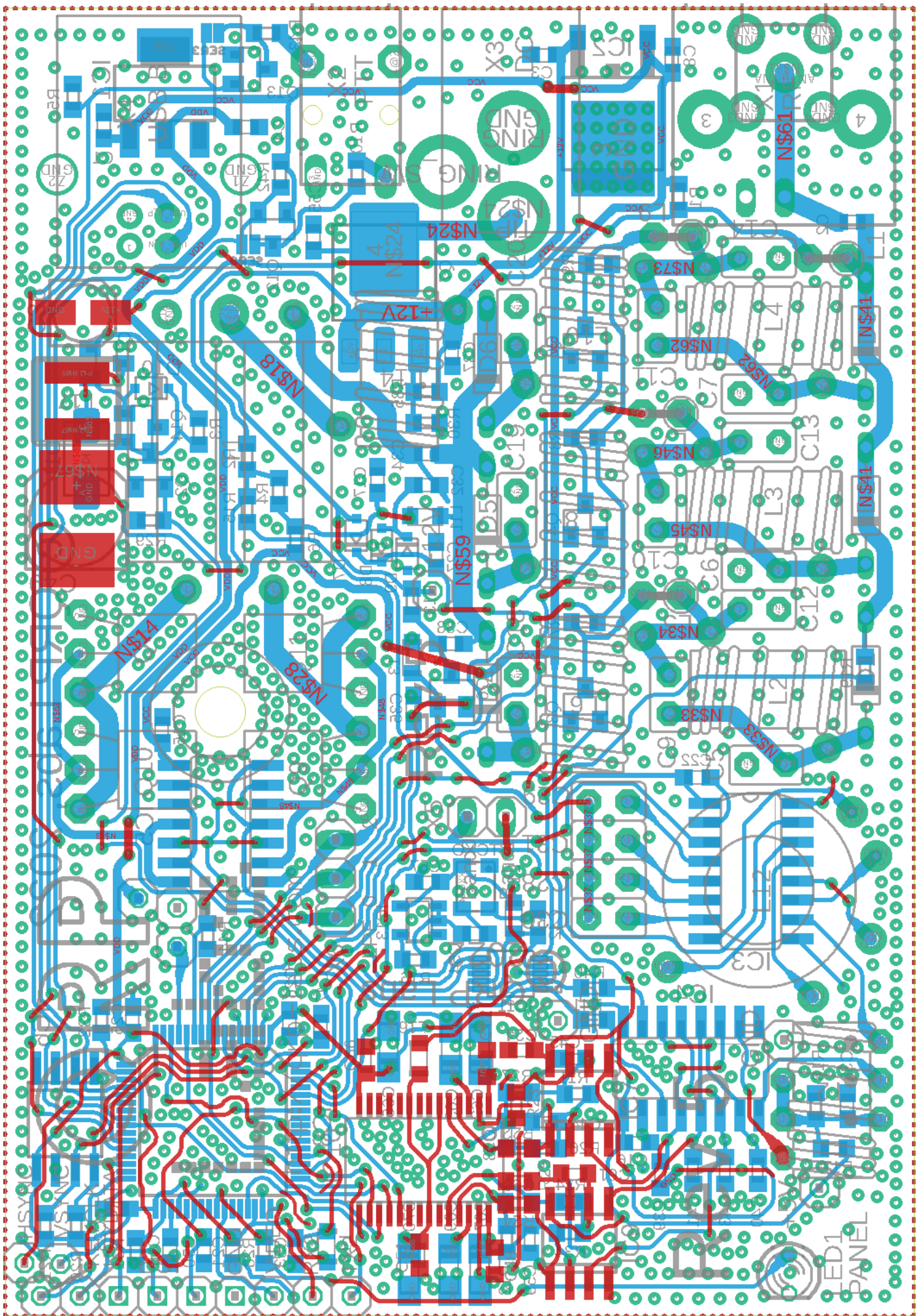

2.2 Parts list

Many components are SMD, pre-soldered to the PCB in the factory. Only through-hole components need to be installed by the constructor. SMD components in the parts list are identified in the Description column and by the text colour being purple.

Resistors

Qty	Value	Description	Component numbers
2	0-ohms	SMD 0603	R31, 32
2	33-ohms	SMD 0603	R2, 4
6	47-ohms	SMD 0603	R22, 23, 24, 25, 40, 41
2	100-ohms	SMD 0603	R11, 34
7	470-ohms	SMD 0603	R10, 12, 14, 26, 27, 28, 43
4	1K	SMD 0603	R1, 6, 20, 21
7	10K	SMD 0603	R3, 13, 15, 17, 18, 30, 35
4	100K	SMD 0603	R5, 19, 29, 42, 44
4	470K	SMD 0603	R7, 8, 9, 16

Capacitors (50V, Multi-layer Ceramic capacitors)

(see below for listing of band-version dependent capacitors)

Qty	Value	Description	Component numbers
2	47pF	SMD 0603	C27, 32
4	4.7nF	SMD 0603	C44, 45, 59, 61
3	10nF	SMD 0603	C36, 58, 60
26	0.1uF	SMD 0603	C15, 16, 17, 21, 22, 23, 24, 25, 26, 33, 35, 37, 46, 47, 49, 50, 51, 52, 53, 54, 57, 66, 71, 72, 73, 74
2	1uF	SMD 3216 tantalum	C63, 69
11	2.2uF	SMD 0603	C1, 2, 3, 4, 8, 34, 38, 42, 48, 50, 55
2	10uF	SMD 0603	C64, 68
4	10uF	SMD 3216 tantalum	C62, 65, 67, 70
1	22uF	SMD 0405 electrolytic	C36
1	470uF	SMD 0607 electrolytic	C49

Semiconductors

Qty	Description	Component numbers
4	SMD: 1N4148 SOD323	D7, 8, 9, 10
1	SMD: SS14 DO-214AC	D
6	1N4007 diode	D1, 2, 3, 4, 5, 6
1	SMD: AMS1117-3.3	IC1
1	SMD: 78M05	IC2
2	SMD: FST3253 SOIC	IC3, 4
1	SMD: 74ACT08	IC5
1	SMD: 24C64	IC6

Qty	Description	Component numbers
2	SMD: LM4562	IC7, 9
1	STM32F401RBT6	IC8
1	PCM1804	IC10
1	SMD: Si5351A / MS5351M	IC11
1	SMD: SN74LVC1G00DBVR	IC13
2	SMD: BSS84 MOSFET	Q1, 12
6	SMD: BSS123 MOSFET	Q2, 3, 4, 5, 6, 13
4	BS170: TO92 MOSFET	Q8, 9, 10, 11
1	SMD: BC817 NNP SOT23-3	Q14
1	SMD: AOD403 (TO252)	Q7
1	3mm Red LED	PANEL
1	SMD: 25MHz TCXO module	TCXO

Inductors

(see below for listing of band-version dependent inductors)

Qty	Description	Component numbers
5	SMD: 47uH	L11, 13, 15, 16, 18
1	SMD: 330uH (CD54)	L17
4	47uH axial inductor	L1, 5, 7, 9
1	FT37-43 10t	L14
1	BN43-202 binocular, 3:3	T1
1	FT37-43 10t trifilar	T2

Miscellaneous

Qty	Value	Description
1	2.1 mm DC	2.1 x 5.5 barrel DC power connector
1	USB B	USB type B connector
1	BNC	RF connector
1	3.5mm jack	3.5mm Stereo connector (PTT)
1	PCB	Main PCB, 86 x 59.5 mm
1	310 cm (80-20m version) 250 cm (20-10m current) 110 cm (20-10m version pre Mar'23)	0.33 mm diameter wire (AWG #28) (varies depending on QDX version as noted)
1	50 cm (80-20m version) 50cm (20-10m version current) 175cm (20-10m version pre Mar '23)	0.60 mm diameter wire (AWG #22) (varies depending on QDX version as noted)
1	M3 12 mm	Steel 12mm long M3 screw
1	M3	Steel M3 nut
1	M3 12 mm	Steel 12mm diameter M3 washer

Enclosure (OPTIONAL)

Qty	Value	Description
2	Top, Bottom	Extruded aluminium top and bottom cover
1	Front panel	Laser etched, drilled for 3mm LED
1	Rear panel	Laser etched, drilled for three connectors
8	M2.5 machine screw	Screws to secure end panels
4	Rubber foot	Self-adhesive rubber foot

Frequency dependent parts:

80 / 60 / 40 / 30 / 20m version of QDX:

Capacitors (50V, Multi-layer Ceramic capacitors):

Qty	Value	Description	Component numbers
1	22pF	Label "220"	C29
1	30pF	Label "300"	C31
2	56pF	Label "56J"	C10, 28
1	82pF	Label "820"	C11
1	100pF	Label "101"	C9
1	180pF	Label "181"	C20
1	220pF	Label "221"	C30
1	270pF	Label "271"	C7
2	390pF	Label "391"	C6, 19
2	470pF	Label "471"	C5, 14
2	820pF	Label "821"	C13, 18
1	1200pF	Label "122"	C12

Inductors (powdered iron Micrometals toroids):

Qty	Description	Component numbers
1	T37-2 toroid (red), 2.40 uH (24t)	L2
1	T37-2 toroid (red), 2.88 uH (26t)	L6
1	T37-6 toroid (yel), 1.06 uH (18t)	L3
1	T37-6 toroid (yel), 393 nH (11t)	L4
1	T37-6 toroid (yel), 1.20 uH (20t)	L8
1	T37-6 toroid (yel), 525 nH (13t)	L10
1	T50-2 toroid – tapped, see text	L12

20 / 17 / 15 / 12 / 11 / 10m version of QDX:

Capacitors (50V, Multi-layer Ceramic capacitors):

Qty	Value	Description	Component numbers
2	30pF	Label "300" or "30J"	C29, 31
1	33pF	Label "330" or "33J"	C28
1	39pF	Label "390" or "39J"	C30
1	15pF	Label "150" or "15J"	C11
1	22pF	Label "220" or "22J"	C9
3	120pF	Label "121"	C5, 18, 20
1	47pF	Label "470" or "47J"	C10
1	82pF	Label "820" or "82J"	C7
3	270pF	Label "271"	C6, 12, 19
1	180pF	Label "181"	C14
1	560pF	Label "561"	C13

Inductors (powdered iron Micrometals toroids):

NOTE: different toroids supplied before March 2023, see table below this one.

Qty	Description	Component numbers
1	T37-17 toroid (yellow/blue), 640 nH (21t)	L2
1	T37-17 toroid (yellow/blue), 722 nH (21t)	L6
1	T37-17 toroid (yellow/blue), 202 nH (12)	L3
1	T37-17 toroid (yellow/blue), 250 nH (13t)	L4
1	T37-17 toroid (yellow/blue), 250 nH (12t)	L8
1	T37-17 toroid (yellow/blue), 302 nH (14t)	L10
1	T50-6 toroid – tapped, see text	L12

- OR – (supplied pre March 2023):

Qty	Description	Component numbers
1	T37-10 toroid (shiny black), 640 nH (16t)	L2
1	T37-10 toroid (shiny black), 722 nH (17t)	L6
1	T37-10 toroid (shiny black), 202 nH (9t)	L3
1	T37-10 toroid (shiny black), 250 nH (10t)	L4
1	T37-10 toroid (shiny black), 250 nH (10t)	L8
1	T37-10 toroid (shiny black), 302 nH (11t)	L10
1	T50-6 toroid – tapped, see text	L12

2.3 Inventory parts

Note: Photo shows parts for PCB Rev 3, 80/60/40/30/20m version of the QDX.

Note: Capacitor colours vary depending on availability. All are NP0/COG Class-I RF dielectric.

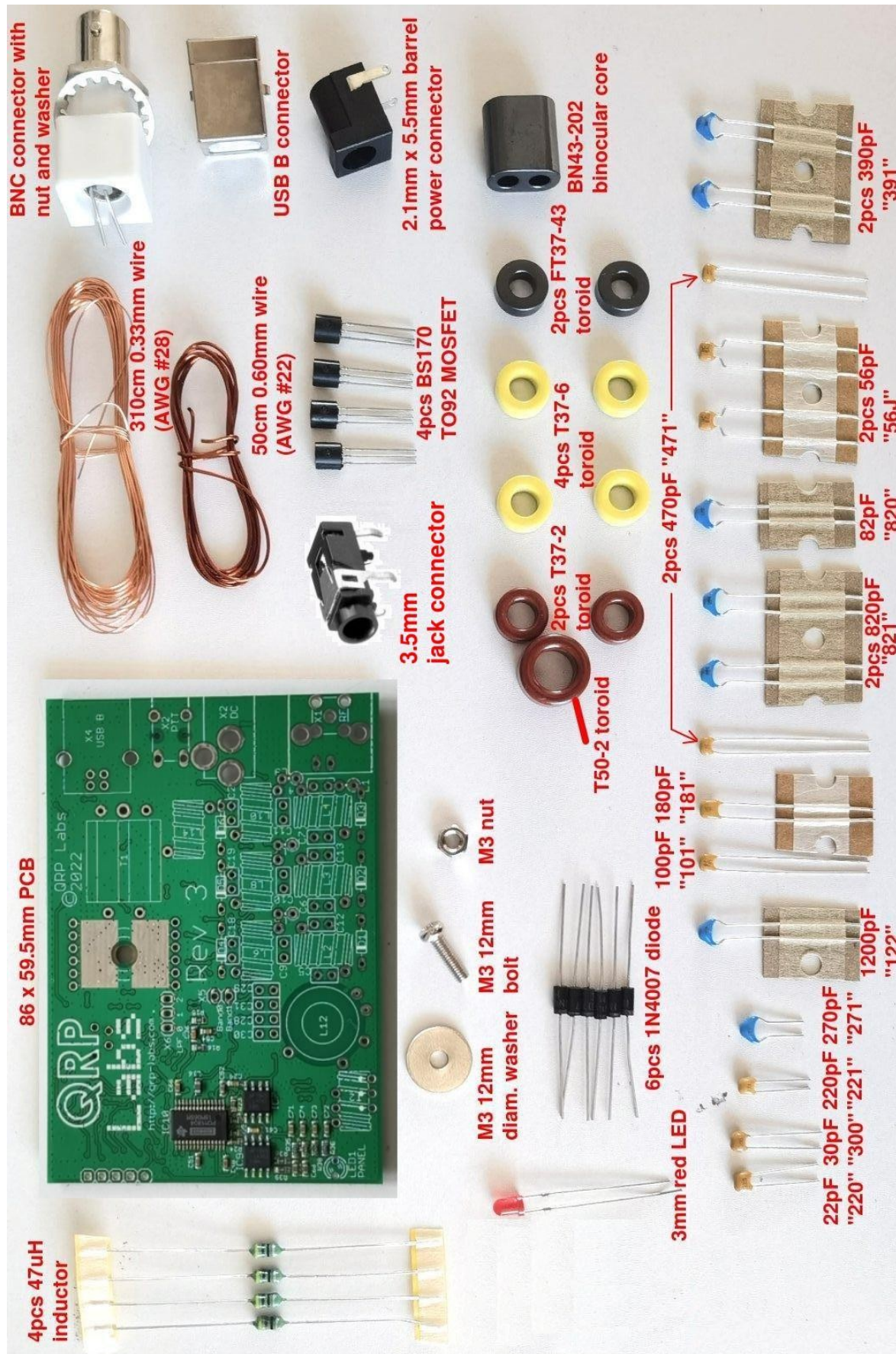

2.4 Install all the ceramic capacitors

80 / 60 / 40 / 30 / 20m version: (see following page for high-band QDX version): Install all 16 through-hole capacitors in accordance with the following diagram. The procedure is so easy that I have included all capacitors in a single assembly step rather than doing one diagram for each capacitor value. Nevertheless be very careful to insert the correct value capacitors in the correct places. Mistakes are hard to correct later.

In the diagram, the component label (capacitor body inscription) is written inside the capacitor body, which **may be supplied coloured yellow, or blue, according to availability**. The actual value e.g. 220pF is written in red text next to the capacitor. Note that the leads of some capacitors may need to be bent to fit the 2.5mm holes.

Qty	Value	Description	Component numbers
2	470pF	Through-hole, label "471"	C5, 14
2	390pF	Through-hole, label "391"	C6, 19
1	270pF	Through-hole, label "271"	C7
1	100pF	Through-hole, label "101"	C9
2	56pF	Through-hole, label "56J" or "560"	C10, 28
1	82pF	Through-hole, label "820"	C11
1	1200pF	Through-hole, label "122"	C12
2	820pF	Through-hole, label "821"	C13, 18
1	180pF	Through-hole, label "181"	C20
1	22pF	Through-hole, label "220"	C29
1	220pF	Through-hole, label "221"	C30
1	30pF	Through-hole, label "300"	C31

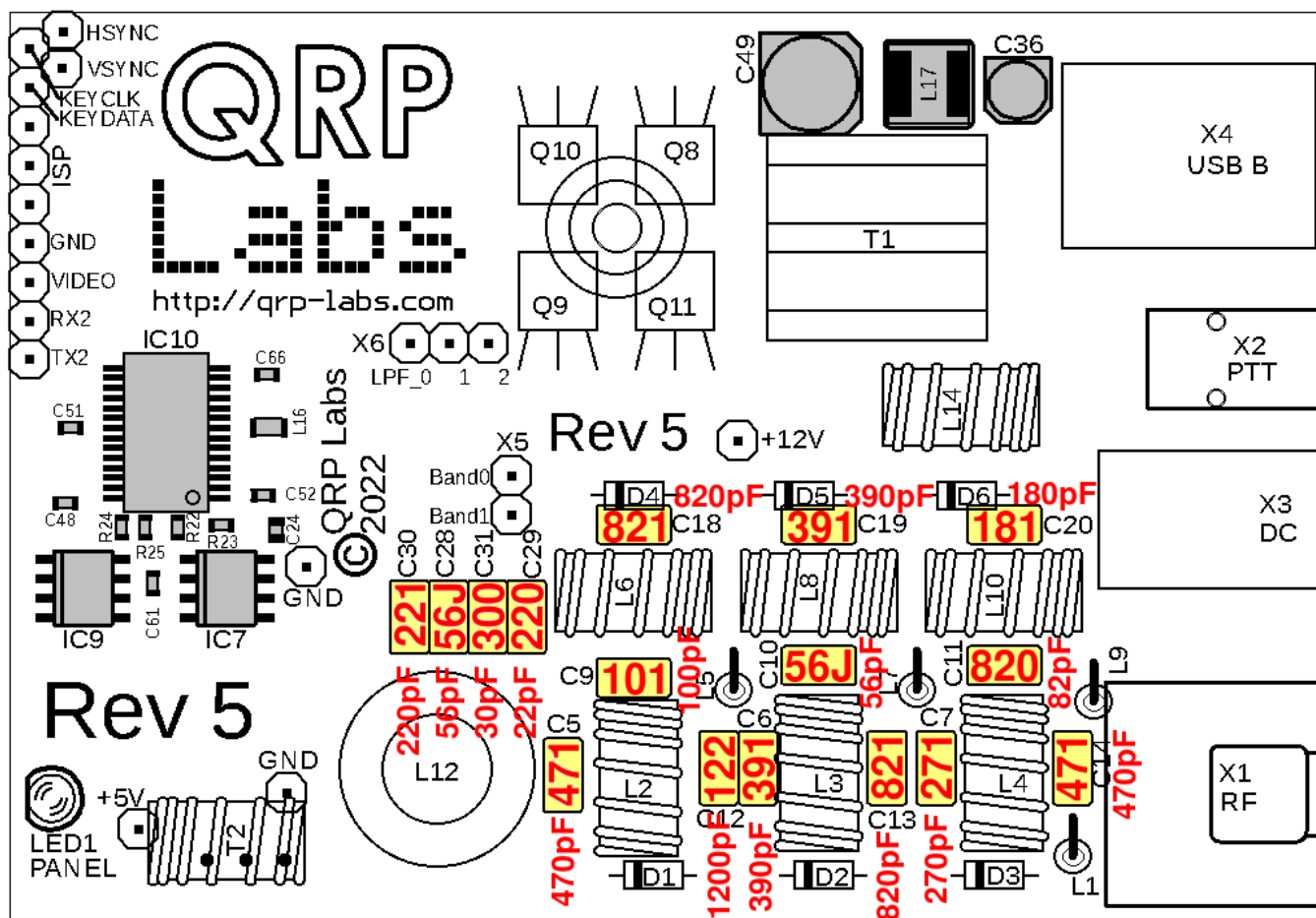

20 / 17 / 15 / 12 / 11 / 10m version: Install all 16 through-hole capacitors in accordance with the following diagram. The procedure is so easy that I have included all capacitors in a single assembly step rather than doing one diagram for each capacitor value. Nevertheless be very careful to insert the correct value capacitors in the correct places. Mistakes are hard to correct later.

In the diagram, the component label (capacitor body inscription) is written inside the capacitor body, which **may be supplied coloured yellow, or blue, according to availability**. The actual value e.g. 220pF is written in red text next to the capacitor. Note that the leads of some capacitors may need to be bent to fit the 2.5mm holes.

Qty	Value	Description	Component numbers
2	30pF	Label "300" or "30J"	C29, 31
1	33pF	Label "330" or "33J"	C28
1	39pF	Label "390" or "39J"	C30
1	15pF	Label "150" or "15J"	C11
1	22pF	Label "220" or "22J"	C9
3	120pF	Label "121"	C5, 18, 20
1	47pF	Label "470" or "47J"	C10
1	82pF	Label "820" or "82J"	C7
3	270pF	Label "271"	C6, 12, 19
1	180pF	Label "181"	C14
1	560pF	Label "561"	C13

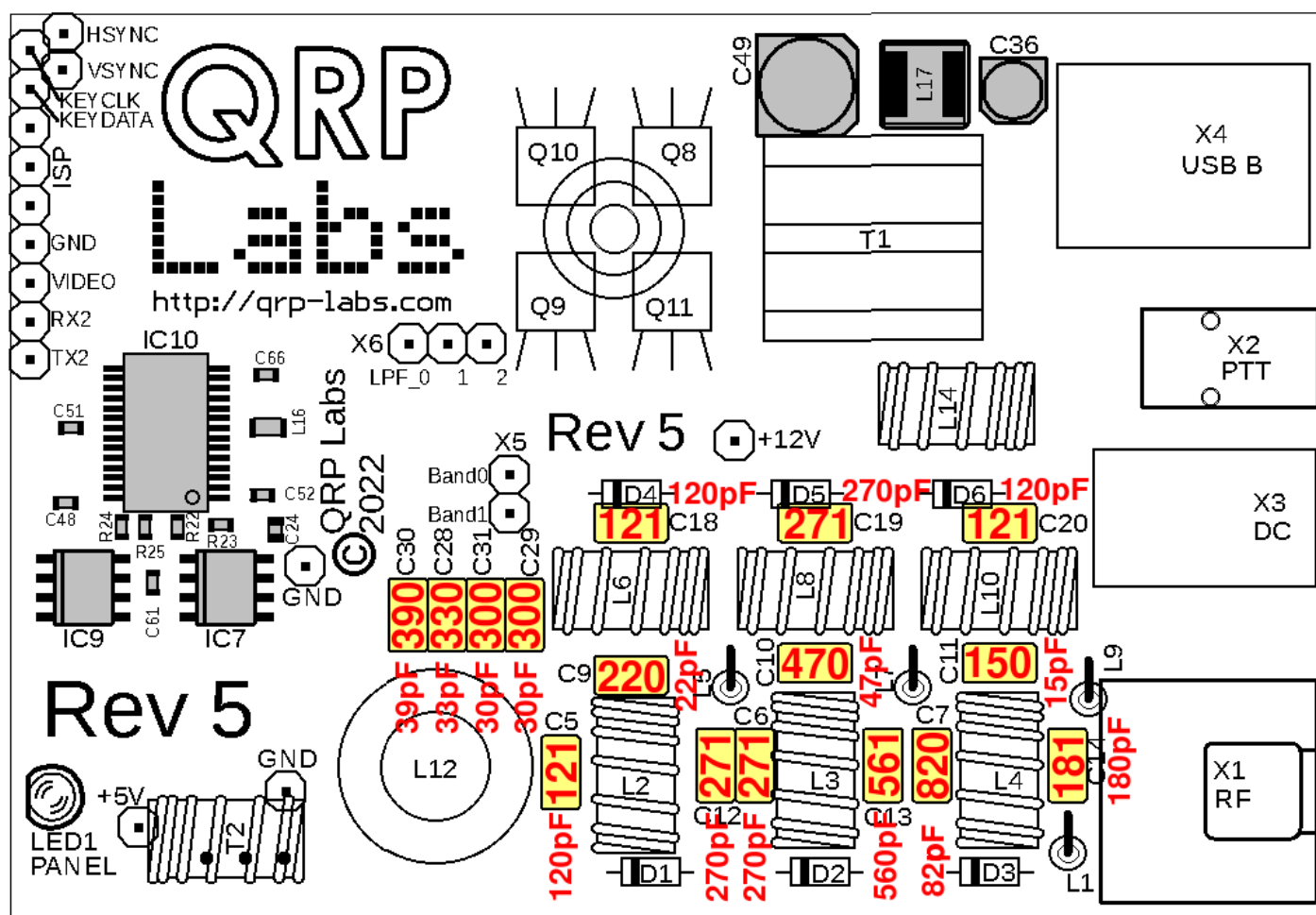

2.5 Install 1N4007 diodes

Install the six 1N4007 diodes D1-D6.

Pay attention to the orientation of the diodes which is critically important. The diodes have a black body and a white stripe. The white stripe end must be aligned with the white stripe on the image on the PCB silkscreen. In the diagram below, all the white stripe ends of the diodes are on the left of each diode position.

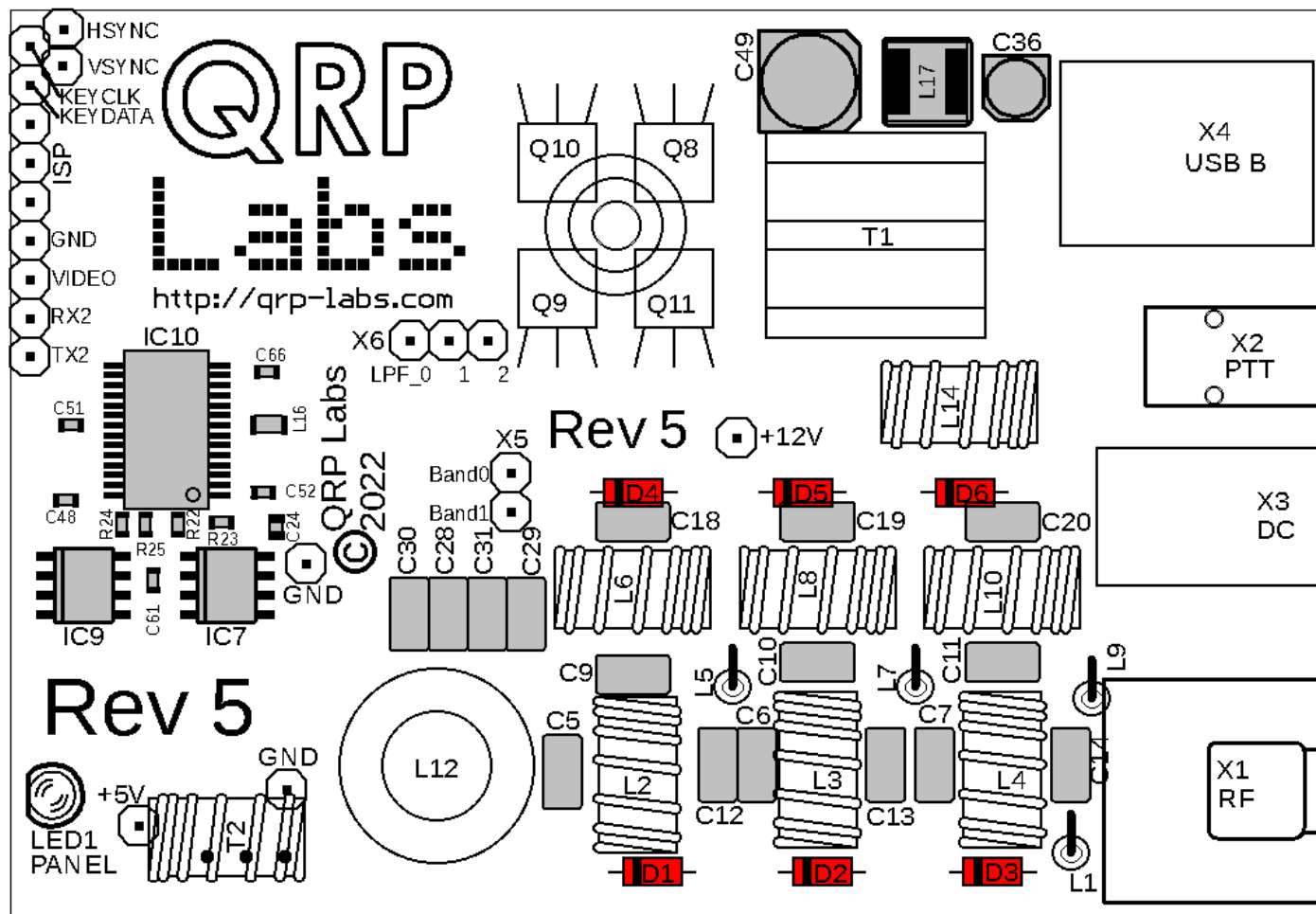

So far, the assembly should look like this →

(80 / 60 / 40 / 30 / 20m Rev 4 version pictured)

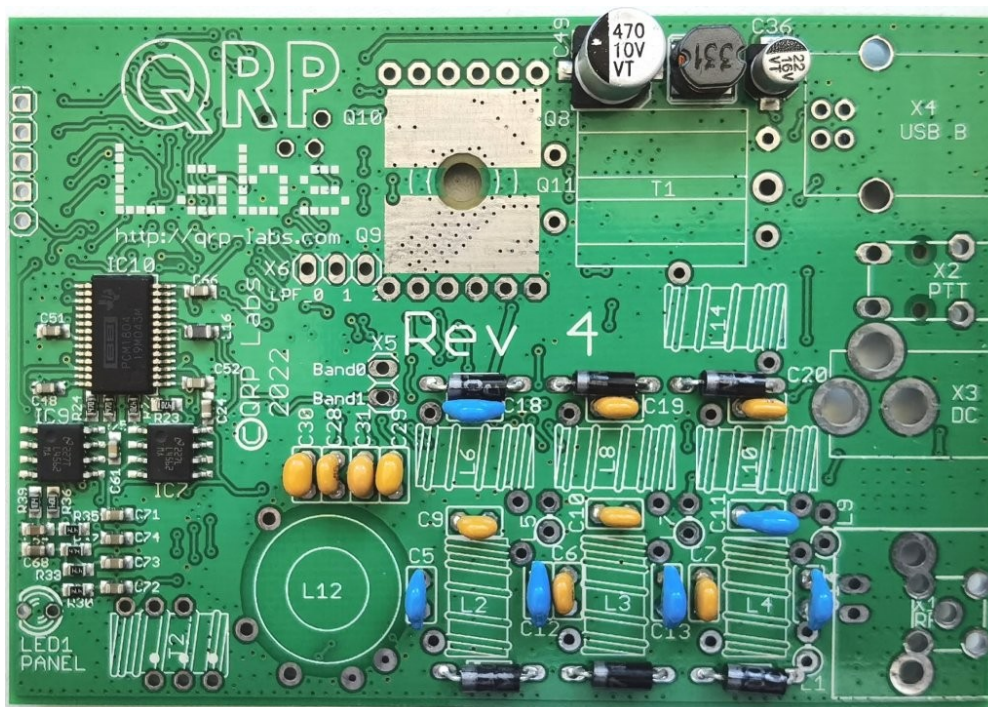

2.6 Install 47uH inductors

Install the four 47uH axial inductors L1, L5, L7 and L9. Bend one lead over 180-degrees so that the inductor body stands up vertically at 90-degrees to the PCB.

The orientation of these is not particularly important, but my recommendation is to follow the silkscreen PCB pattern, putting the body (longer lead) nearer to the PCB lower edge (as orientated in the diagram below) and the wire (shorter lead) nearer to the top side.

NOTE: Several people worried that there should not be a connection at the end of L1 nearest the board edge, to the thick output trace. There IS a connection here! So don't try to remove the connection, a solder bridge between one end of L1 and one end of D3 is normal and CORRECT!

(photo by Paolo 31JS20)

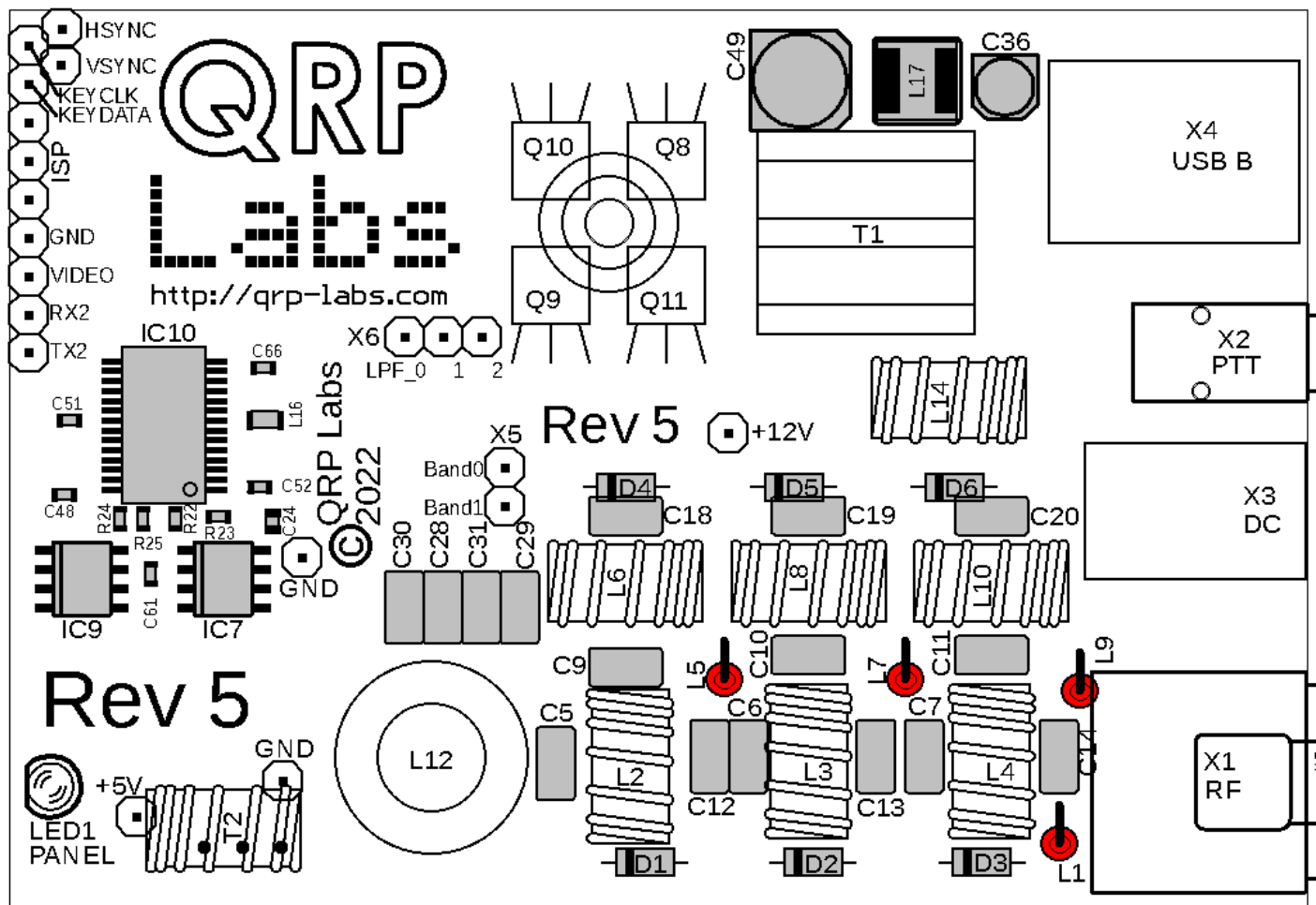
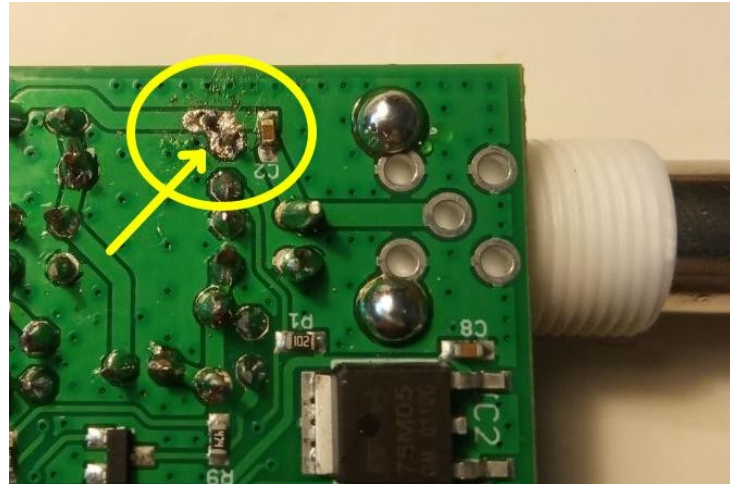

2.7 Install PA transistors

Install the transistors in the positions shown, with their flat faces flush against the PCB.

Use the 12mm M3 bolt, washer and nut to firmly press the transistor faces against the PCB, as shown.

Refer to the diagram and photographs below.

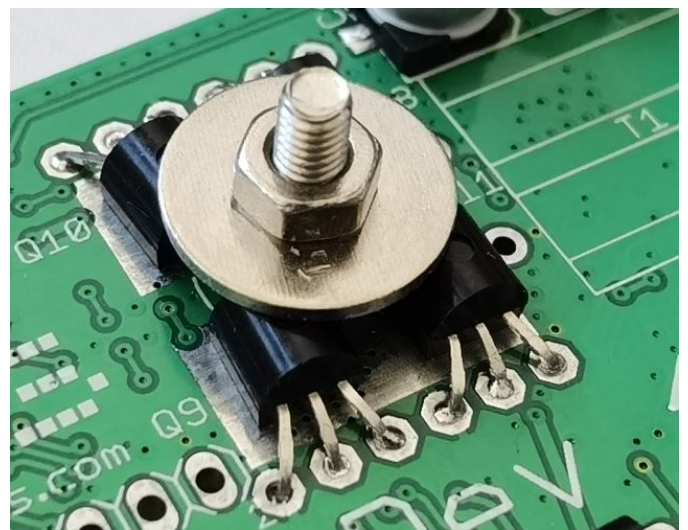
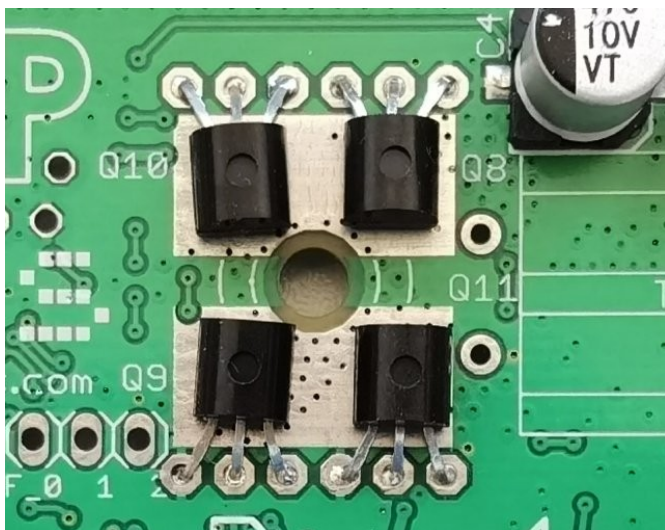
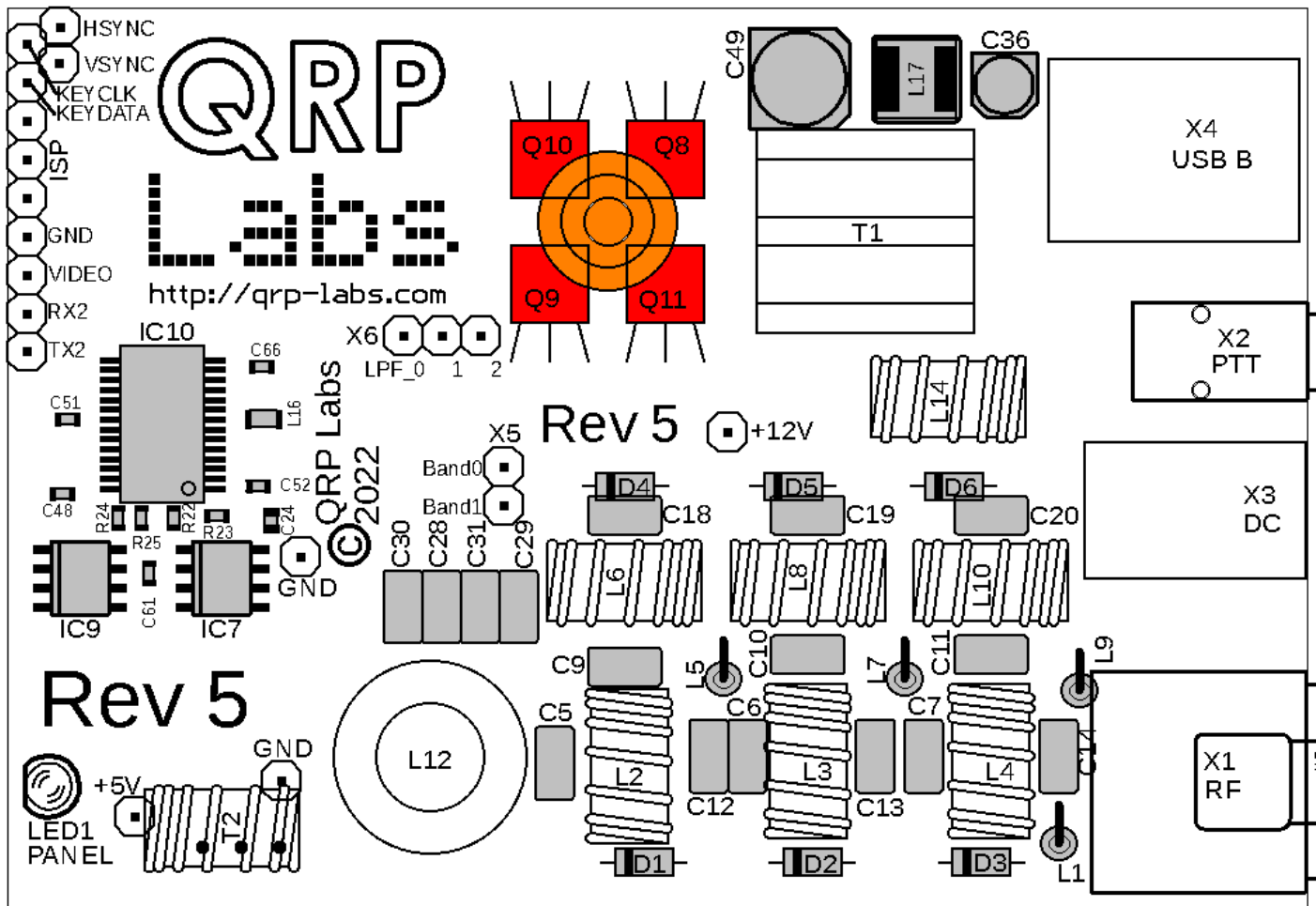

2.8 Assemble and install transformer T1

Transformer 1 is wound on the binocular ferrite former, using the thick 0.6mm (AWG #22) wire. This wire is also used for L14 so do not use all of it on the transformer.

Please refer to the separate document that describes the preparation of this transformer.

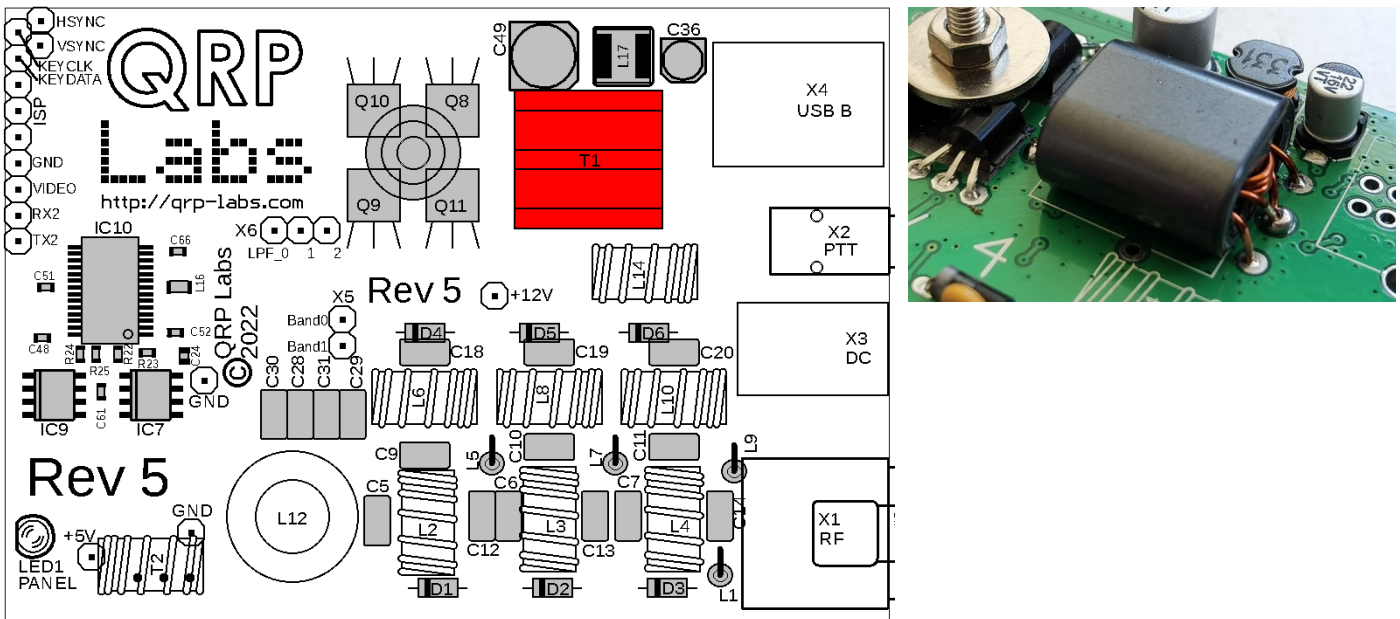

When the transformer is ready, insert the wires into the holes on the PCB, and continue with the installation steps listed here. For historical reasons the diagrams start at step 12... because the transformer winding instructions were moved to a separate document.

Step 12: Now we need to get the enamel off the wire. Usually on thinner wire, I hold the soldering iron to the wire until the enamel burns off. But that doesn't work so well on thicker wire such as this. So my technique here is to scrape the enamel off, at least partially, using wire cutters. The correct pressure needs to be applied to the wire cutters, so as NOT to actually cut the wire. I hold the wire cutter as close to the PCB as possible, then gently but firmly pull the cutter away from the PCB, scratching off the enamel. Turn the cutter to a different angle and scrape again, 2 or 3 times. It is not necessary to remove ALL the enamel, if you get a few good scrapes on, enough enamel will be removed that the soldering iron heat will burn off the rest of the enamel and a good joint will be achieved. Do this for the 4 winding ends first, leave the two center-tap for later, to make it easier.

Step 13: Cut each of the four wire-endings, leaving about 2mm or less, sticking up from the PCB.

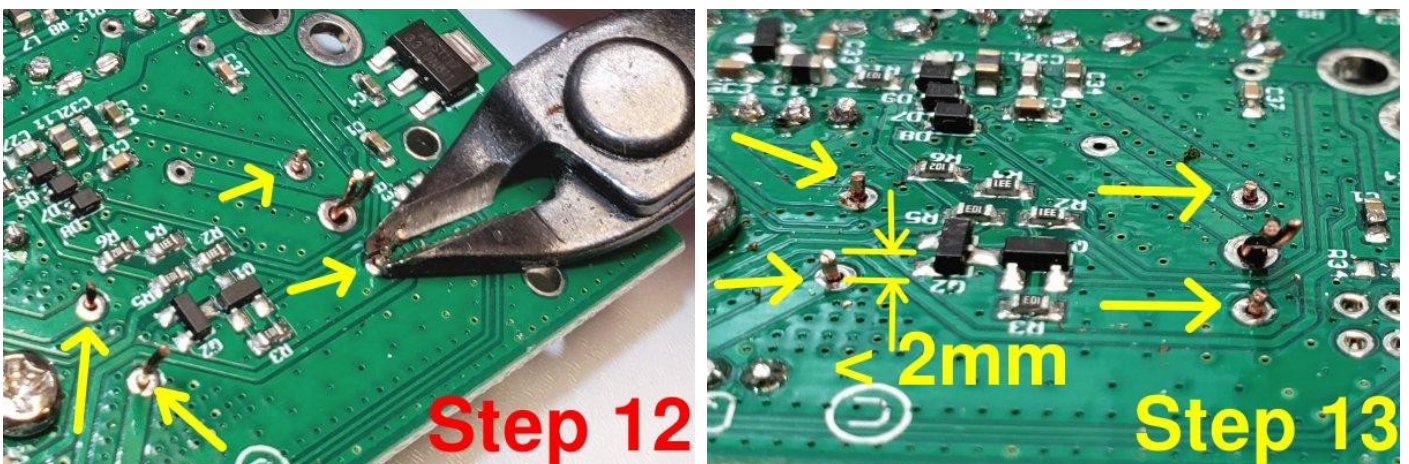

Step 14: Solder the four wire endings. At each pad, hold the soldering iron firmly, apply plenty of solder, and wait for about 10 seconds. This will ensure a good connection, and any remaining enamel will be burned away.

Step 15: Finally repeat the procedure with the two center-tap wires that came through the large center hole. Scrape them, cut them to 2mm, and solder them. Apply plenty of solder and hold the soldering iron tip to the joint for maybe 15 seconds, to really be sure of a good joint and burning away any remaining enamel.

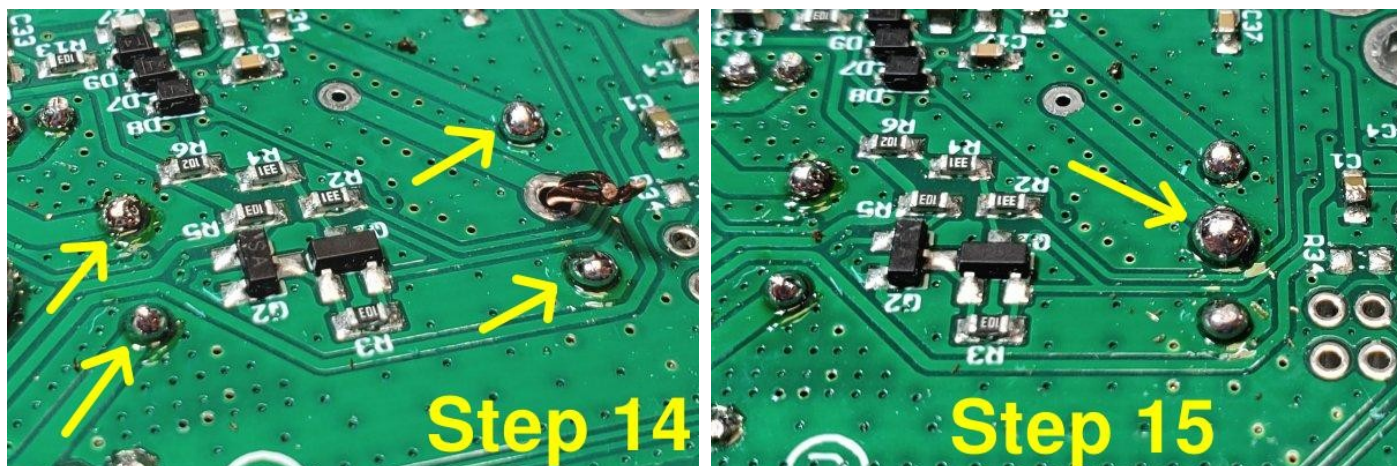

Step 16: Check that none of the wires protrude more than 2mm from the surface of the PCB, since if you are using the optional aluminium enclosure, there are only a few mm clearance.

Step 17: Verify good connections for all five soldered joints of T1 using a DMM set to resistance or continuity mode. My cheap DMM hasn't got a continuity mode and I'm using the 2000-ohm resistance mode; in this mode when there is continuity, the reading on mine shows 001 (not zero-ohms; this is just a DMM thing, of no significance).



You should see continuity between all the points labeled A in the photo below. Touch the probes to pairs of these points, to verify continuity.

You should see continuity between the points labeled B also. Touch the two probes to the two pads labeled B and check for continuity.

Finally, there should be NO connection between A and B. Hold one probe on any A point and the other probe on a B point. That should read infinite resistance (no continuity).

If any of these tests fail, then you have a soldering problem somewhere, or the wrong wire in the wrong hole, or some short-circuit somewhere etc.

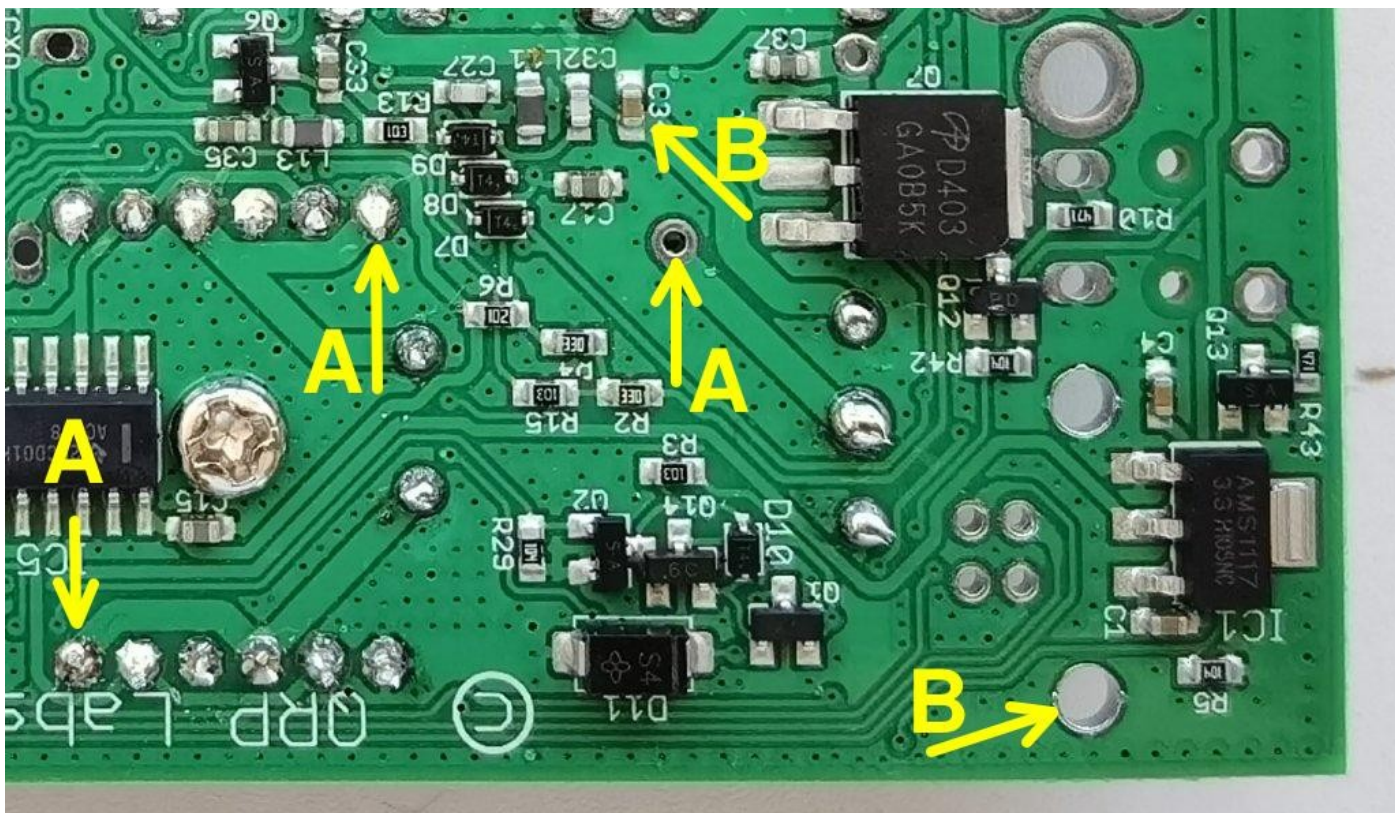

This is the final appearance of T1 when the installation is complete:

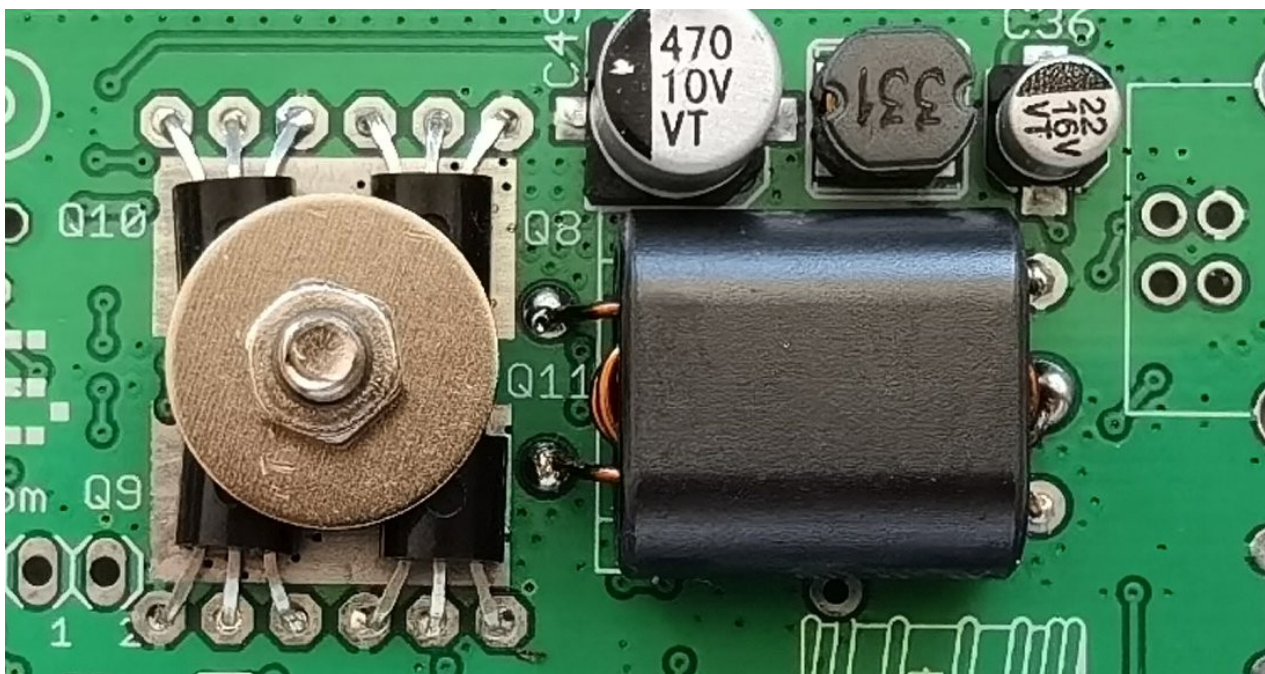

2.9 Prepare and install tapped inductor L12

80 / 60 / 40 / 30 / 20m version (high bands version see next section): L12 is an inductor wound on a T50-2 toroid (red colour, large size), having several taps which are switched in according to the operating frequency (band). There are 41 turns in total, with taps at 19, 30 and 36 turns. The diagram shows the location of the taps at 19, 30 and 36 turns, which have larger holes, such that two wires can be inserted.

Carefully unwind and cut off 75cm of the 0.33mm (AWG #28) enameled wire, and straighten it, ensuring no kinks.

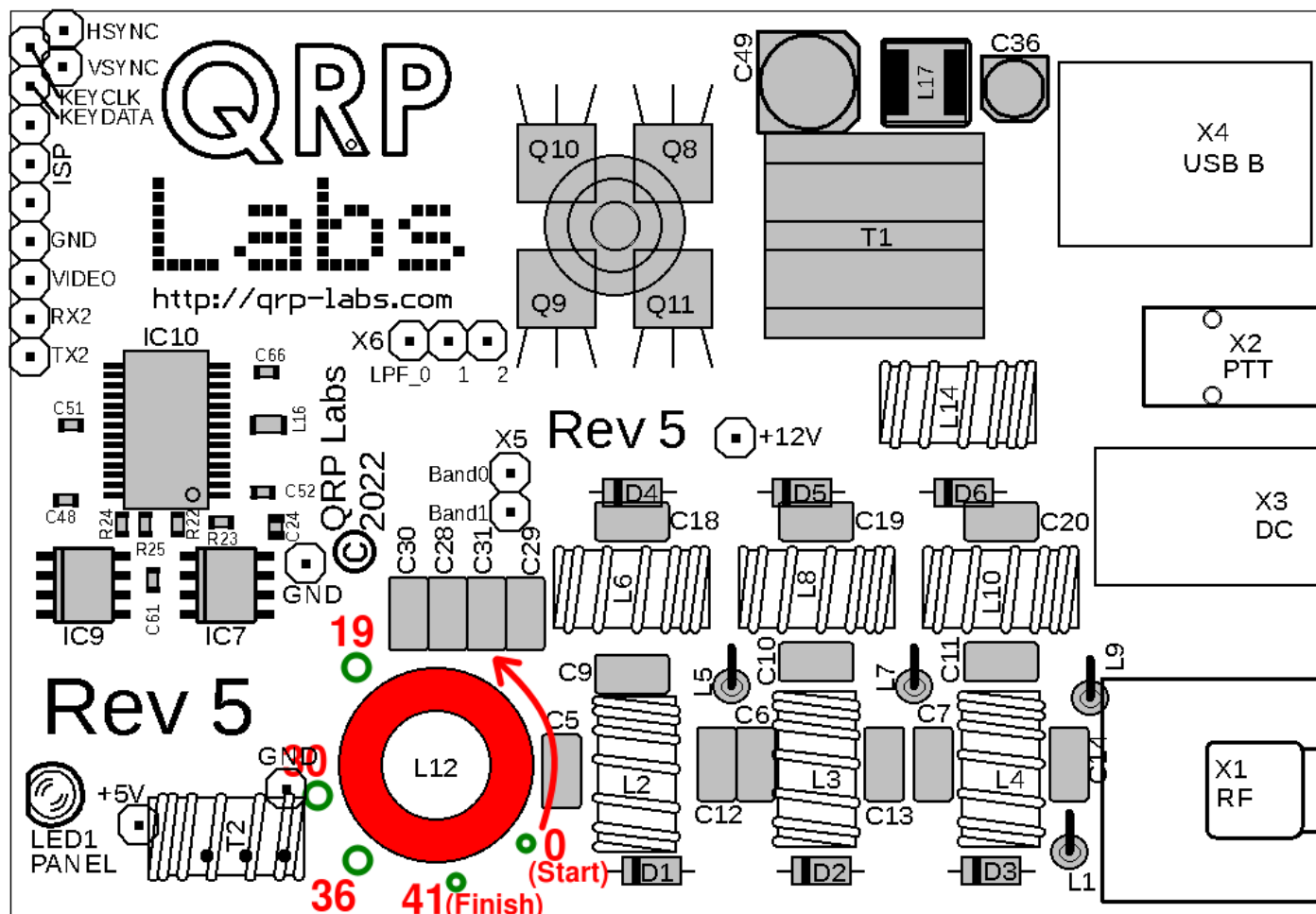

Step 1: Begin winding L12 as shown. Remember that in the nomenclature of toroidal inductors, each time the wire passes through the center of the toroid counts as 1 turn.

Step 2: Wind 19 turns then make a loop between the 19th and 20th turns. This is for the 19 turn tap.



Step 3: Wind up to the 30th turn then make another loop between the 30th and 31st turns. This is for the 30 turn tap.

Step 4: Wind up to the 36th turn then make another loop between the 36th and 37th turns. This is for the 36-turn tap.

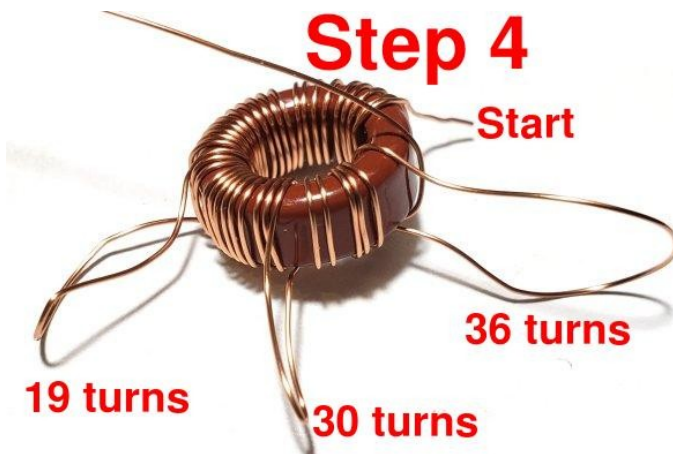
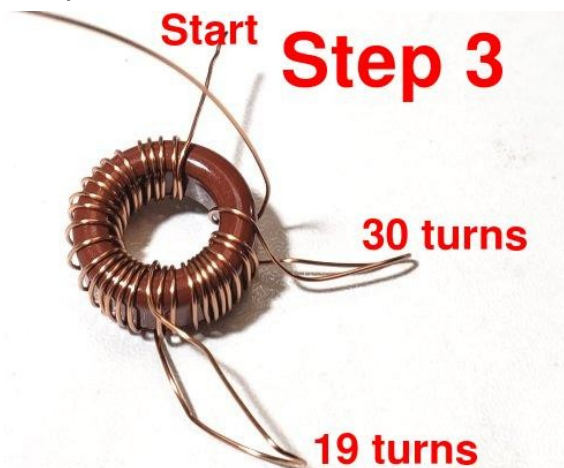

Step 5: Wind the remaining turns to complete the total of 41 turns.

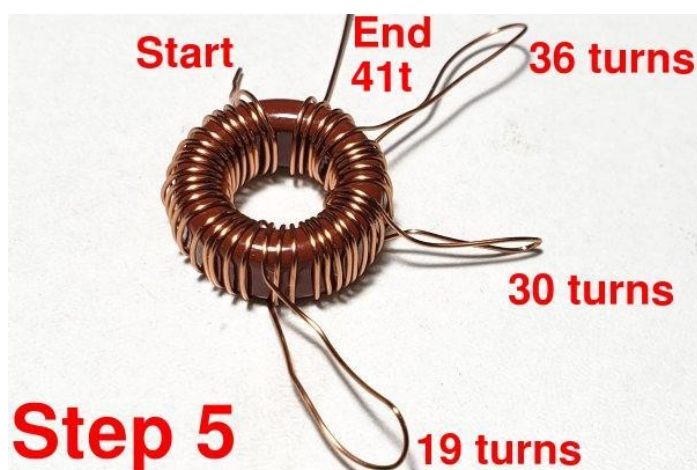

Step 6: Now with a pair of pliers, you can squeeze each of the loops into a sharp point, such that it is easy to fit through the large holes at the 19, 30 and 36-turn taps (see photo, right).



Step 7: Insert all the wires in their correct holes.

You should pull them firmly from the underside of the board to ensure that there are no loose wires on the top side.

Now cut each wire to about 2mm length (at most) and solder in place. It is essential to remove the enamel from the wire. My favourite method of doing this is simply to hold the soldering iron to the joint, with plenty of solder, for at least 10 seconds. The enamel burns away in this time.

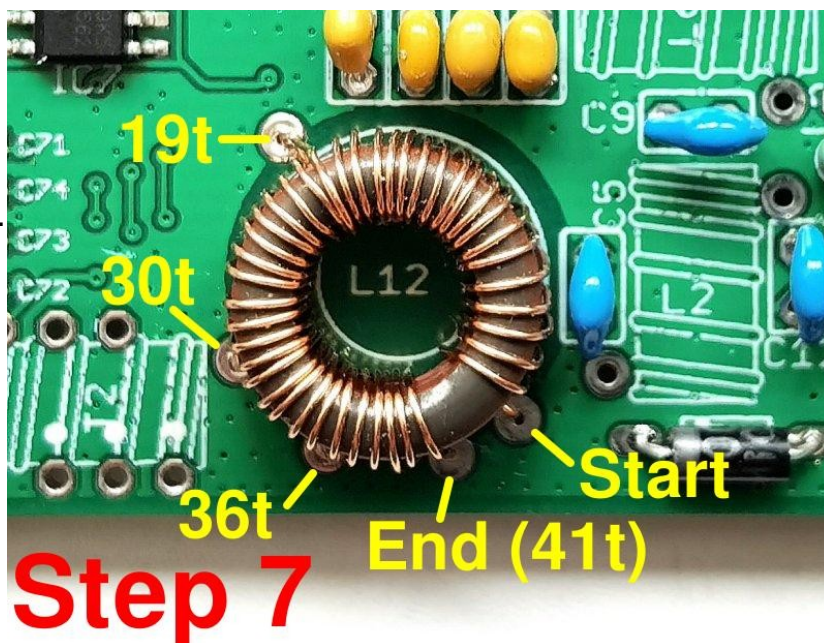

Step 8: Verify the joints are properly soldered, by using a DMM in continuity testing mode (if it has this mode) or check for zero ohms in resistance mode. On the reverse of the PCB, check for continuity between pins 3, 4, 5, 6 and 9 of IC3 as shown. You should measure 0 ohms (continuity) between any pairs of these. If you do not, then there is a mistake somewhere, most probably a failure to burn away the enamel at one or more of the L12 connections to make a good joint.

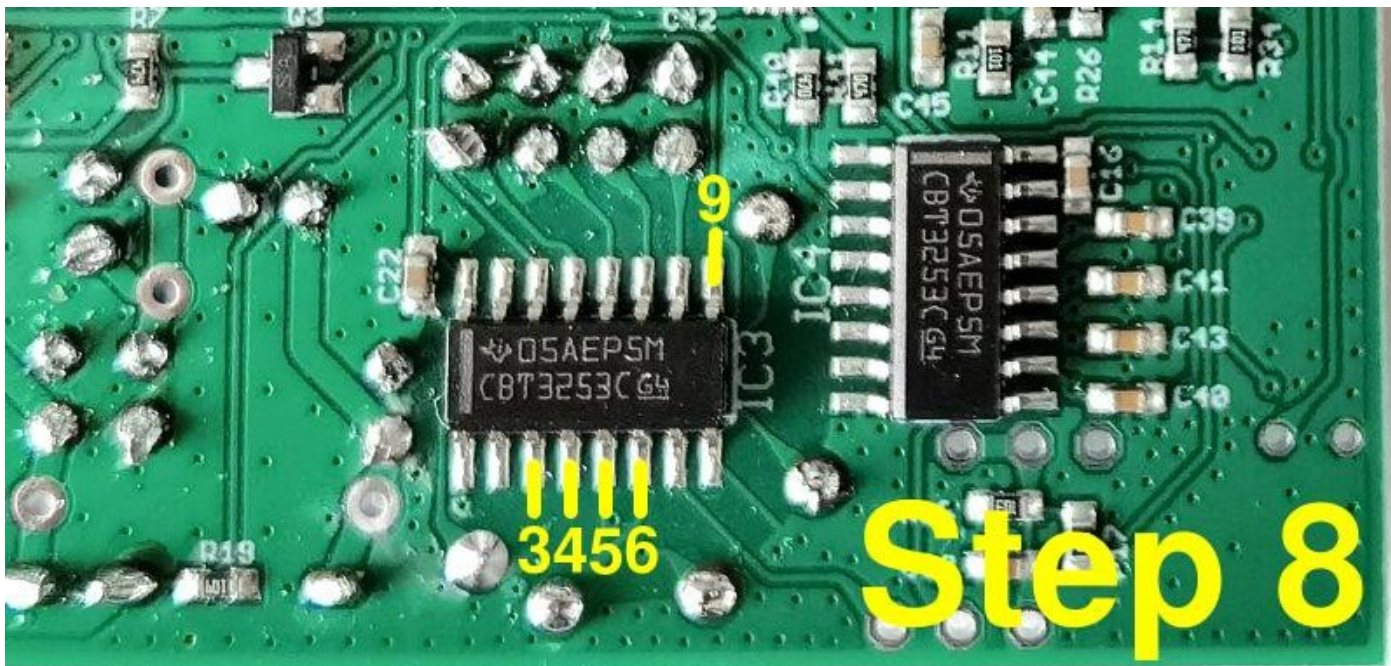

Here's the story so far, including the nicely installed L12 gapped inductor.

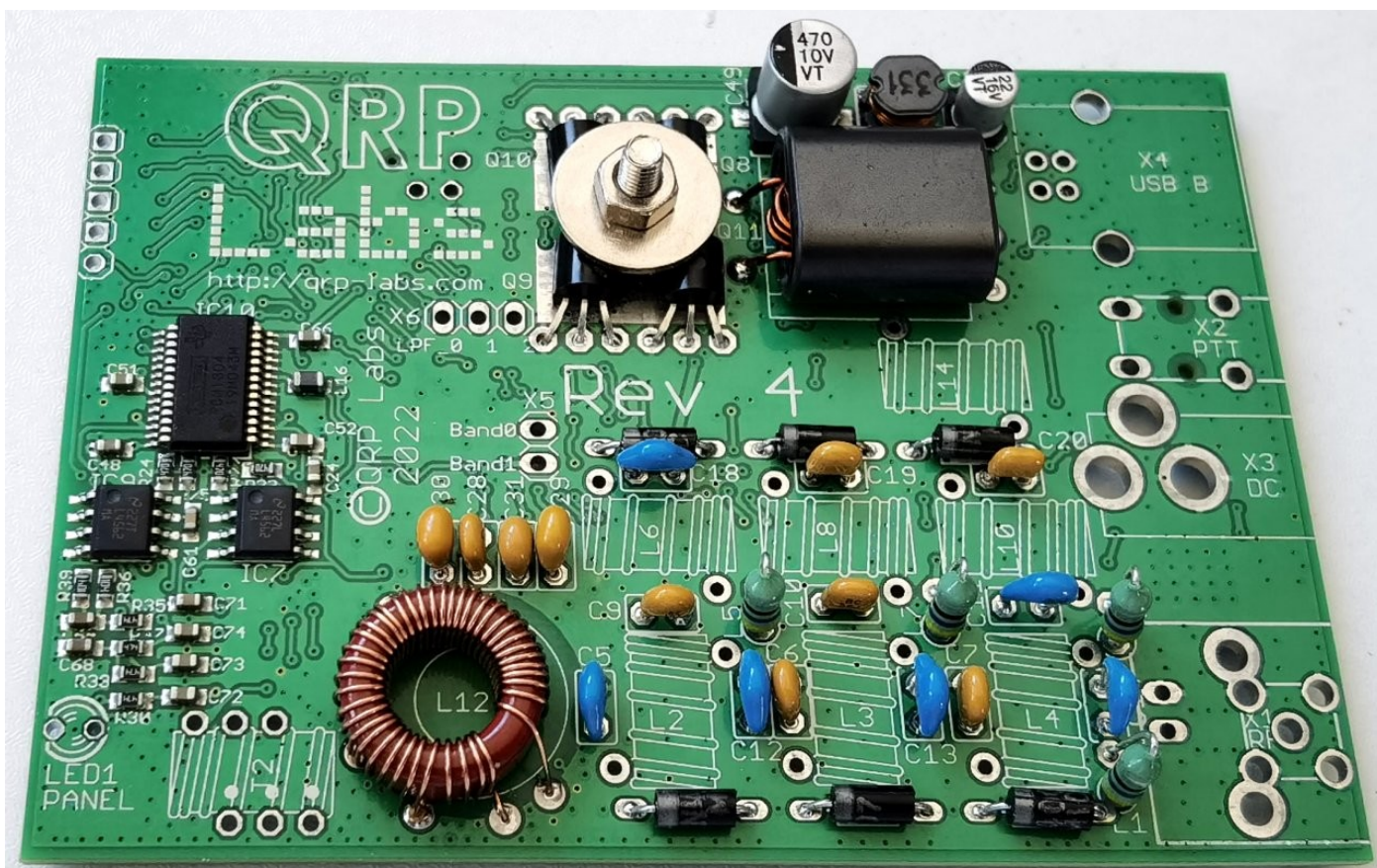

20 / 17 / 15 / 12 / 11 / 10m version: L12 is an inductor wound on a T50-6 toroid (yellow colour, large size), having several taps which are switched in according to the operating frequency (band). There are 20 turns in total, with taps at 11, 14 and 17 turns. The diagram shows the location of the taps at 11, 14 and 17 turns, which have larger holes, such that two wires can be inserted.

Carefully unwind and cut off 50cm of the 0.33mm (AWG #28) enameled wire, and straighten it, ensuring no kinks.

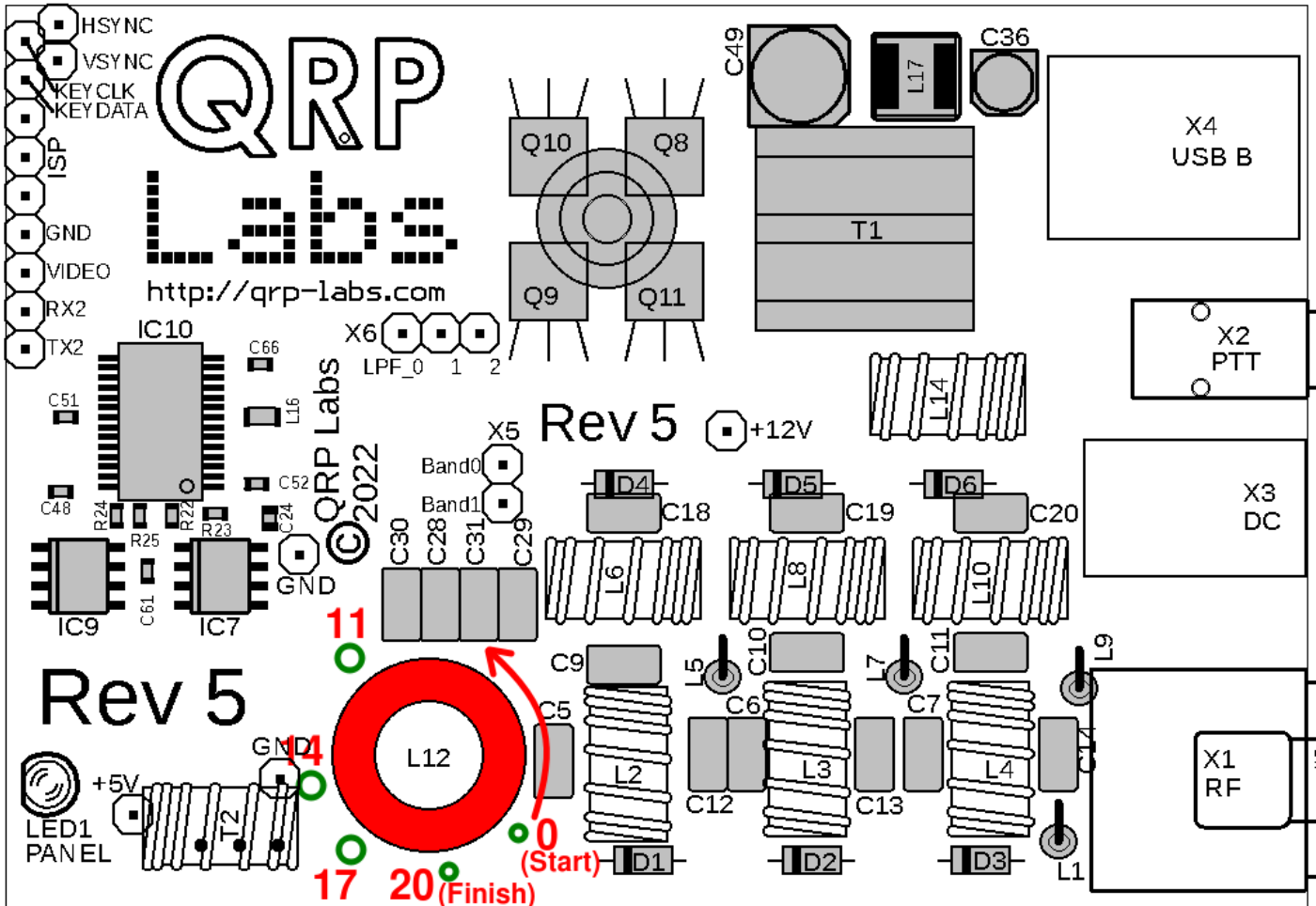

Step 1: Begin winding L12 as shown. Remember that in the nomenclature of toroidal inductors, each time the wire passes through the center of the toroid counts as 1 turn.

Step 2: Wind 11 turns then make a loop between the 11th and 12th turns. This is for the 11 turn tap.

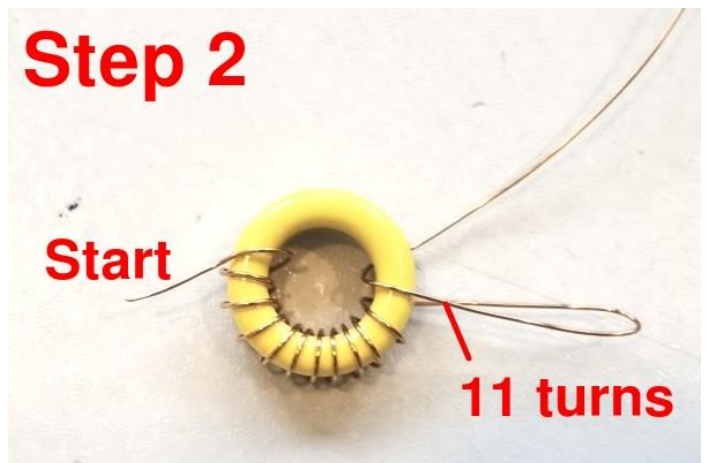
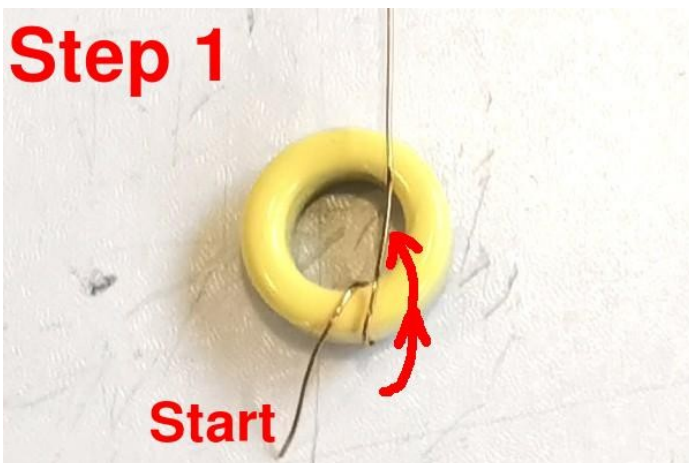

Step 3: Wind up to the 14th turn then make another loop between the 14th and 15th turns. This is for the 14 turn tap.

Step 4: Wind up to the 17th turn then make another loop between the 17th and 18th turns. This is for the 17-turn tap.

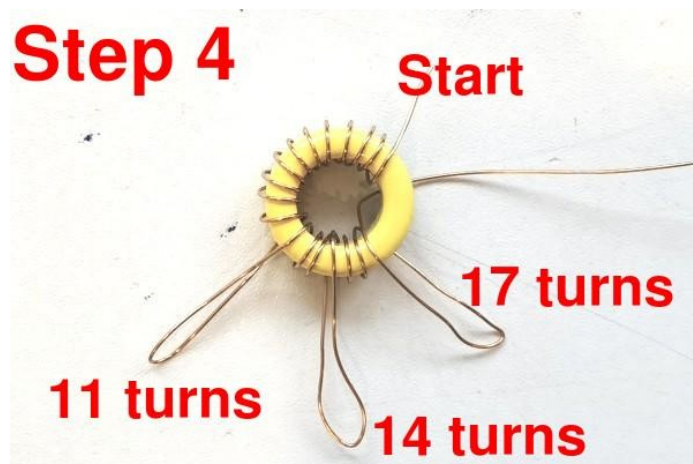
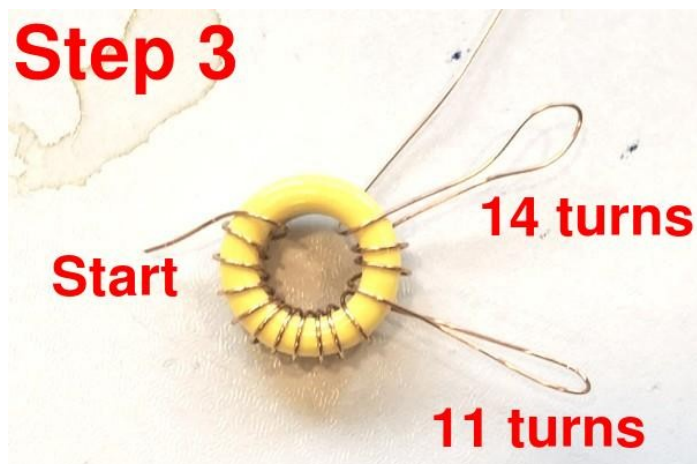

Step 5: Wind the remaining turns to complete the total of 20 turns.

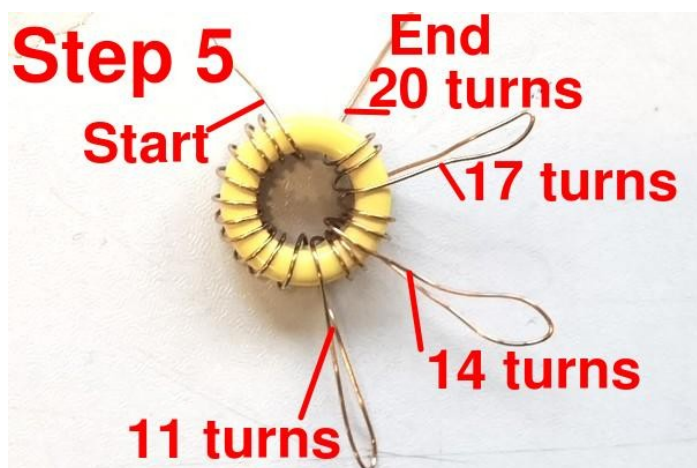

Step 6: Now with a pair of pliers, you can squeeze each of the loops into a sharp point, such that it is easy to fit through the large holes at the 11, 14 and 17-turn taps (see photo, right).



Step 7: Insert all the wires in their correct holes.

You should pull them firmly from the underside of the board to ensure that there are no loose wires on the top side.

Now cut each wire to about 2mm length (at most) and solder in place. It is essential to remove the enamel from the wire. My favourite method of doing this is simply to hold the soldering iron to the joint, with plenty of solder, for at least 10 seconds. The enamel burns away in this time.



Step 8: Verify the joints are properly soldered, by using a DMM in continuity testing mode (if it has this mode) or check for zero ohms in resistance mode. On the reverse of the PCB, check for continuity between pins 3, 4, 5, 6 and 9 of IC3 as shown. You should measure 0 ohms (continuity) between any pairs of these. If you do not, then there is a mistake somewhere, most probably a failure to burn away the enamel at one or more of the L12 connections to make a good joint.

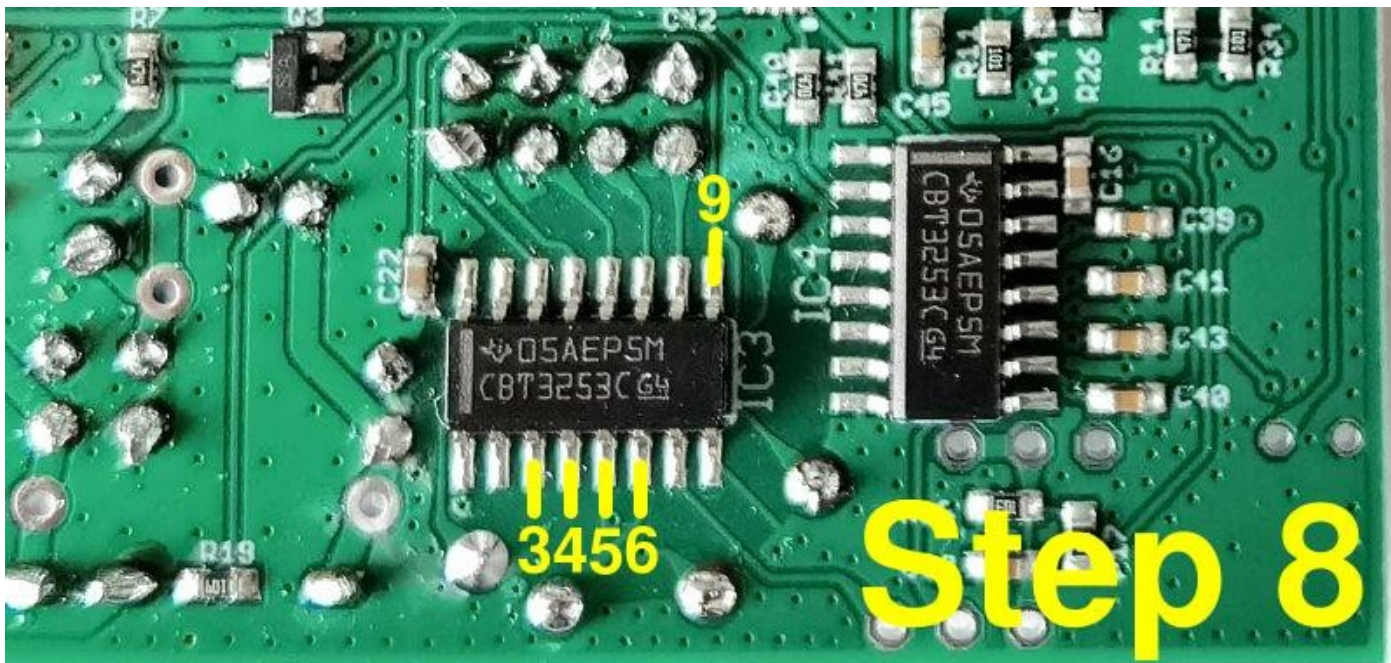

Here's the story so far, including the nicely installed L12 gapped inductor.

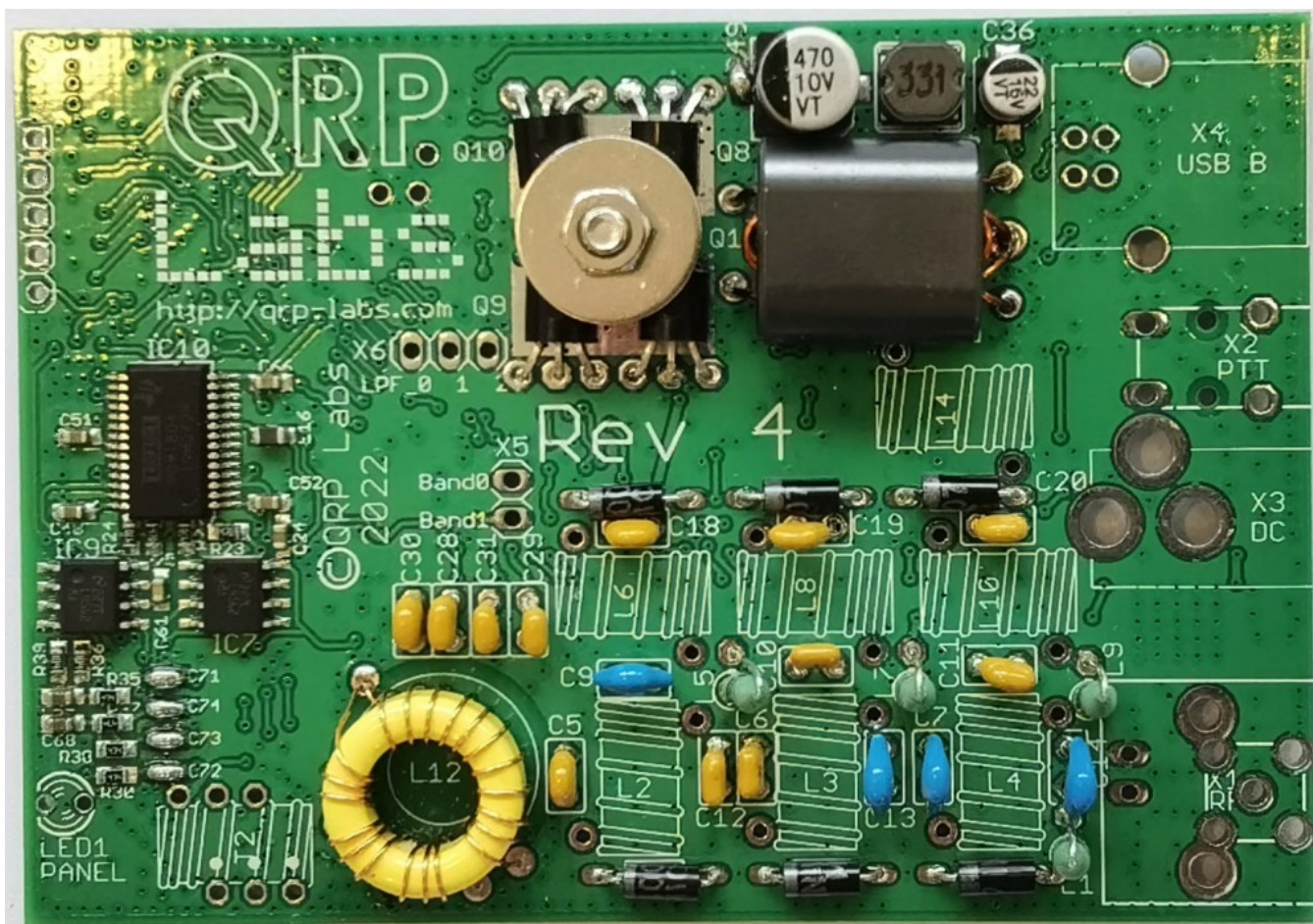

2.10 Wind and install L14

L14 consists of 10 turns of 0.6mm (AWG #22) wire wound on an FT37-43 toroid (dull black colour). Firstly, you have to understand that there's a right way and a wrong way to wind a toroidal inductor, too. The terms "right" and "wrong" are probably not as appropriate here, as "handedness" or "winding direction". There are two directions you can wind the toroid. If you choose the right one, then all the wires will automatically end up near the holes they are to be soldered into. If you do it wrongly, it will be a bit messy.



For all the toroidal inductors in the QDX kit, you will get it right, if you start as shown (photo, above right) and pass the wire through the toroid from the top side down through the hole, out and then around and over again; accumulating turns in the anticlockwise direction.

With this in mind, wind 10 turns and install the toroid. As with the output transformer T1, I recommend scratching the enamel with a knife or wire-cutter, and then cutting it to about 2mm length on the underside of the board. Then solder, applying the soldering iron for at least 10 seconds and plenty of solder, to ensure a good connection. Do NOT tin the wires before inserting into the holes: the holes are not large enough to accommodate tinned wires.

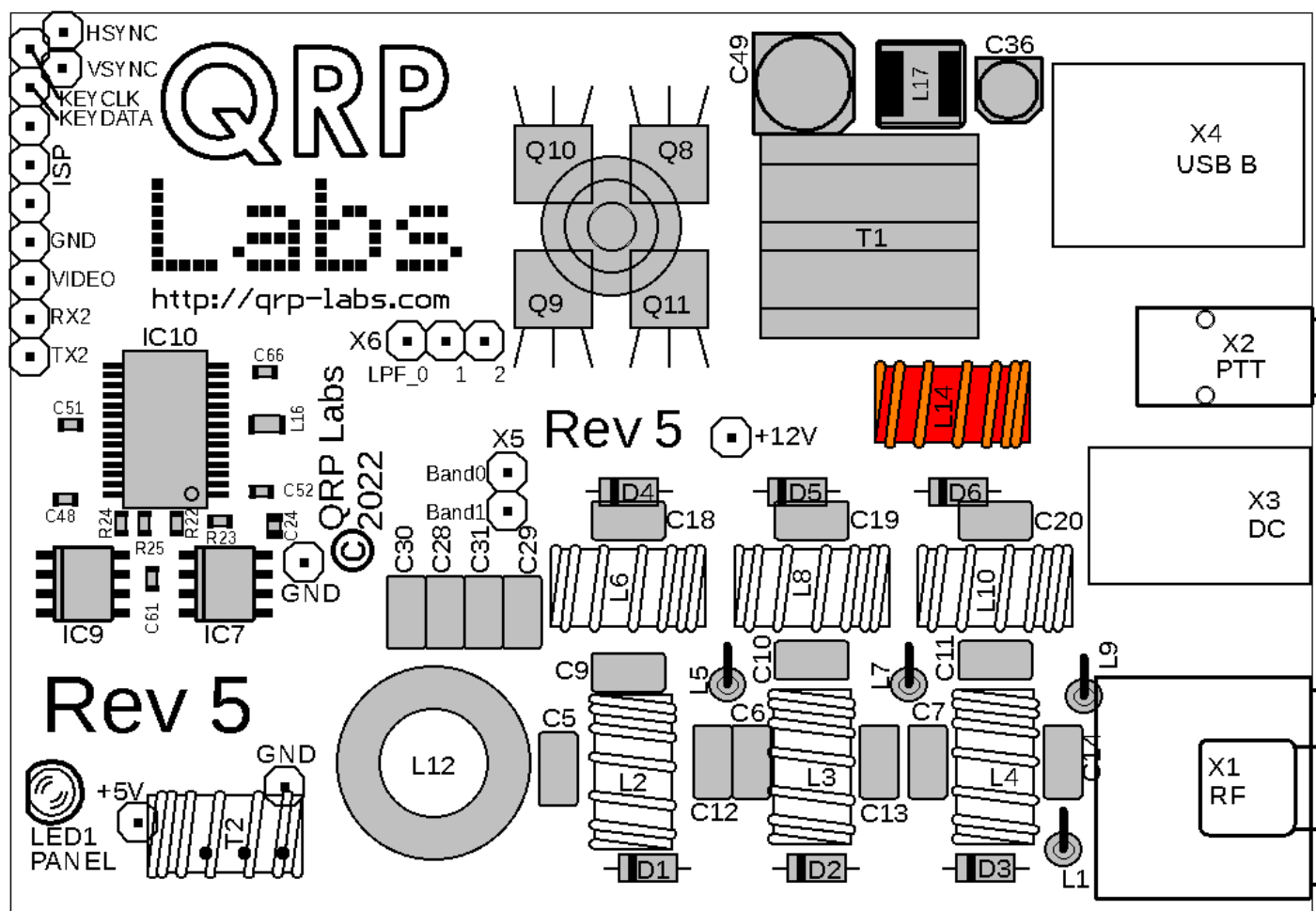

2.11 Install Low Pass Filter toroids

80 / 60 / 40 / 30 / 20m version: Now we'll wind and install the six Low Pass Filter toroids using 0.33mm (AWG #28) enameled wire. Remember, as per the previous direction, using the right winding direction will make the toroids much easier to fit to the PCB. Refer to the table below. Make sure to count carefully and install the toroids in the correct places! Remember that each time the wire passes through the center of the toroid counts as one turn. Spread the turns evenly with a small gap.

Winding the toroids as tightly as possible will slightly improve the performance of the Low Pass Filters. But don't pull so tightly that you break the wire!

The following table lists the required number of turns, cut wire length, and inductance.



Band	Part number	Core	Inductance	Number of turns	Wire length
80m	L2	T37-2 (RED)	2.40uH	24	36cm
80m	L6	T37-2 (RED)	2.88uH	26	39cm
60 / 40m	L3	T37-6 (YELLOW)	1.06uH	18	29cm
60 / 40m	L8	T37-6 (YELLOW)	1.20uH	20	30cm
30m/20m	L4	T37-6 (YELLOW)	393nH	11	20cm
30m/20m	L10	T37-6 (YELLOW)	525nH	13	22cm

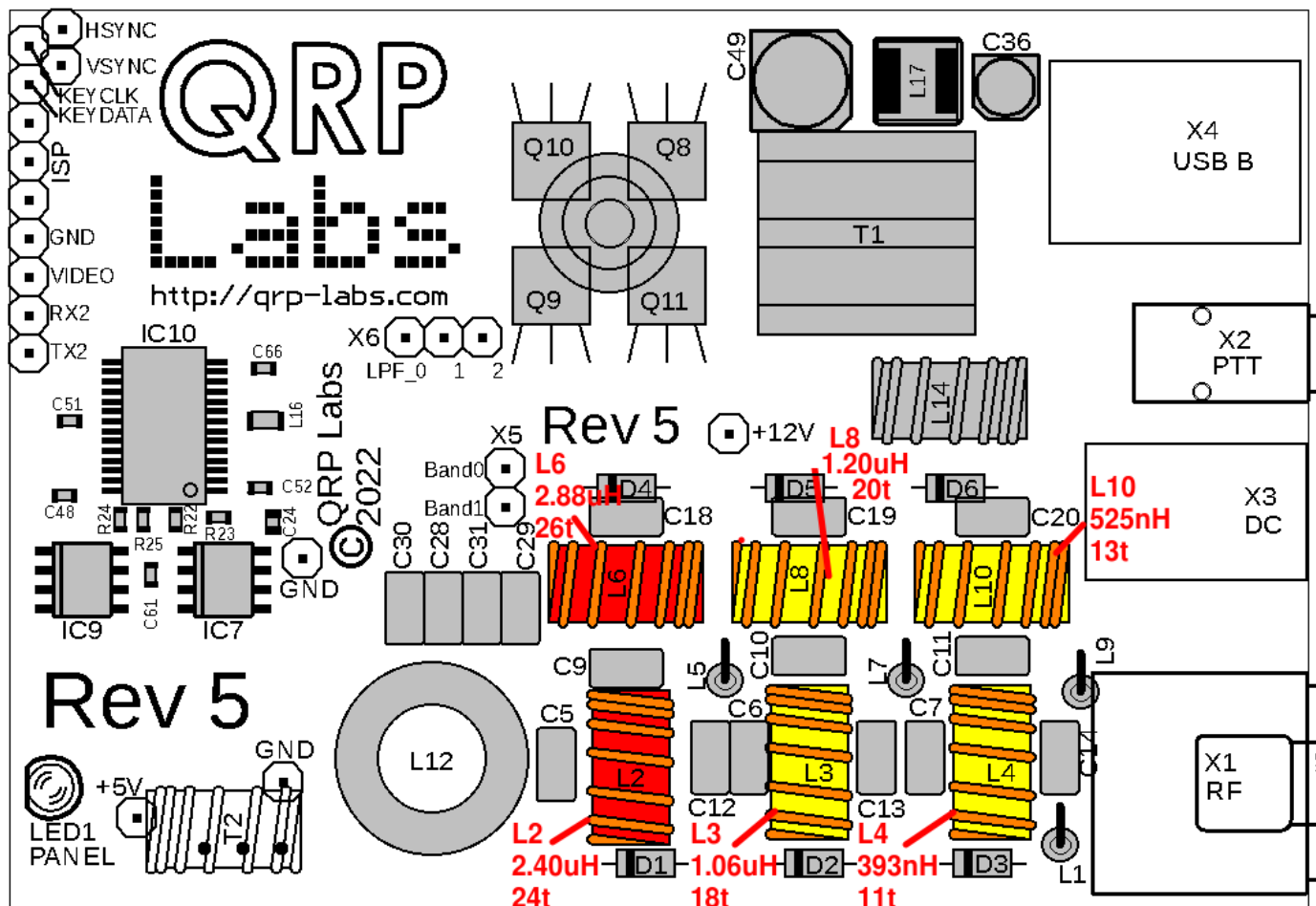

20 / 17 / 15 / 12 / 11 / 10m version supplied

March 2023 onward: These kits have 6

yellow/blue toroids. Now we'll wind and install the six Low Pass Filter toroids using 0.33mm (AWG #28) enameled wire on the **yellow/blue toroids**. Remember, as per the previous direction, using the right winding direction will make the toroids much easier to fit to the PCB. Refer to the table below. Make sure to count carefully and install the toroids in the correct places! Remember that each time the wire passes through the center of the toroid counts as one turn. Spread the turns evenly with a small gap.



Winding the toroids as tightly as possible will slightly improve the performance of the Low Pass Filters.

The following table lists the required number of turns, cut wire length, and inductance.

Band	Part number	Core	Inductance	Number of turns	Wire length
20m	L2	T37-17 (YEL/BLUE)	640nH	21	30cm
20m	L6	T37-17 (YEL/BLUE)	722nH	21	30cm
17 / 15m	L3	T37-17 (YEL/BLUE)	202nH	12	19cm
17 / 15m	L8	T37-17 (YEL/BLUE)	250nH	12	19cm
12 / 11 / 10m	L4	T37-17 (YEL/BLUE)	250nH	13	21cm
12 / 11 / 10m	L10	T37-17 (YEL/BLUE)	302nH	14	22cm

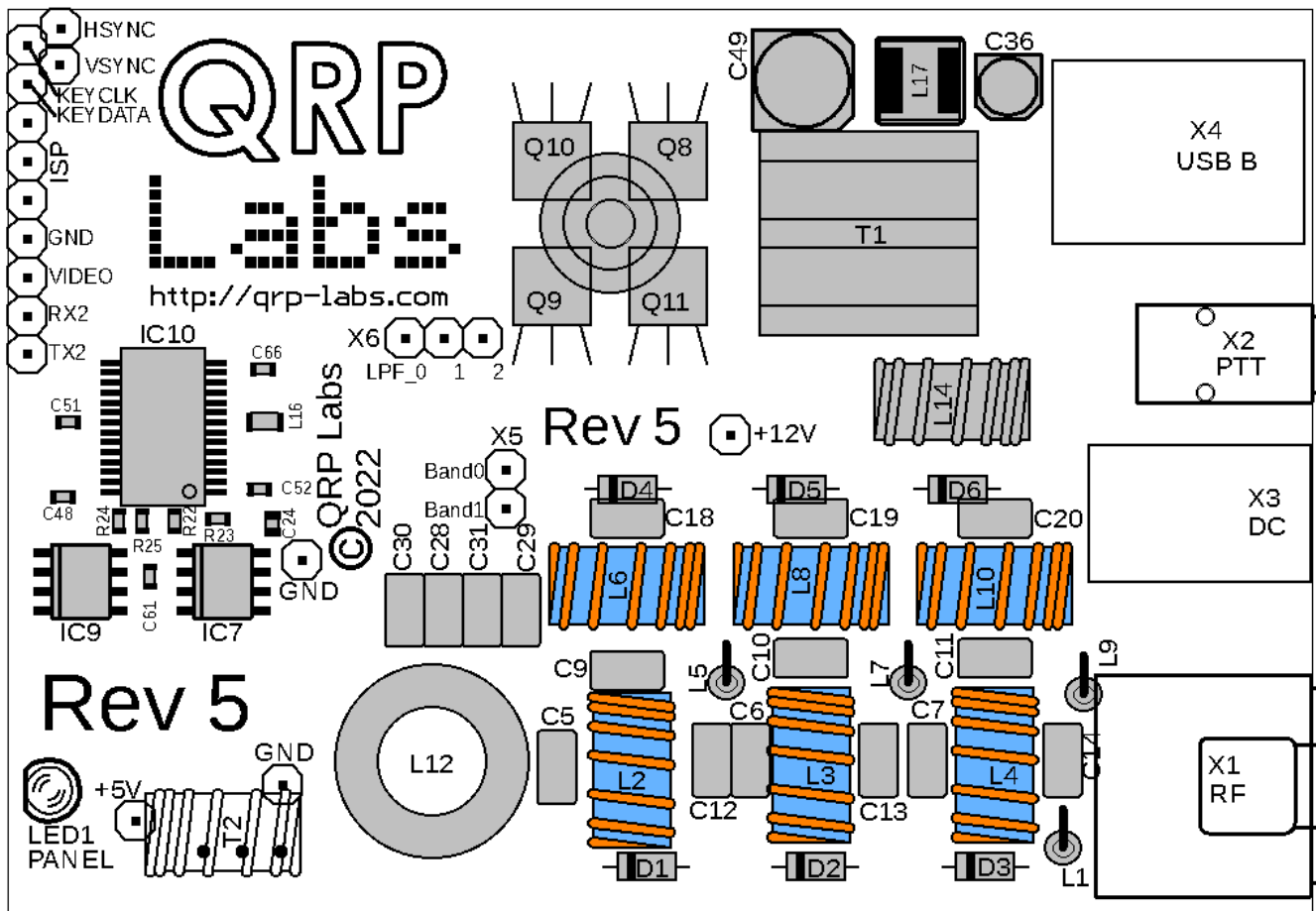

20 / 17 / 15 / 12 / 11 / 10m version (pre March 2023): Kits

are supplied with 6 shiny black toroids. Now we'll wind and install the six Low Pass Filter toroids using 0.60mm (AWG #22) enameled wire on the **shiny black toroids**. You will need to scrape the enamel off the wire and tin the copper before installation. Remember, as per the previous direction, using the right winding direction will make the toroids much easier to fit to the PCB. Refer to the table below. Make sure to count carefully and install the toroids in the correct places! Remember that each time the wire passes through the center of the toroid counts as one turn. Spread the turns evenly with a small gap.

Winding the toroids as tightly as possible will slightly improve the performance of the Low Pass Filters.

The following table lists the required number of turns, cut wire length, and inductance.

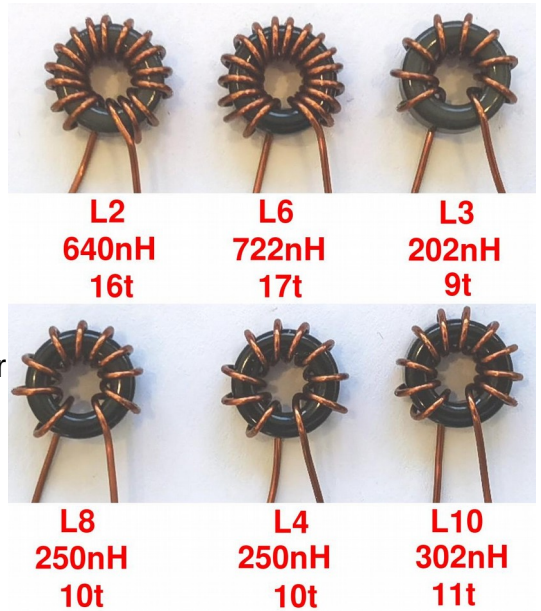

Band	Part number	Core	Inductance	Number of turns	Wire length
20m	L2	T37-10 (BLACK)	640nH	16	25cm
20m	L6	T37-10 (BLACK)	722nH	17	27cm
17 / 15m	L3	T37-10 (BLACK)	202nH	9	16cm
17 / 15m	L8	T37-10 (BLACK)	250nH	10	18cm
12 / 11 / 10m	L4	T37-10 (BLACK)	250nH	10	18cm
12 / 11 / 10m	L10	T37-10 (BLACK)	302nH	11	20 cm

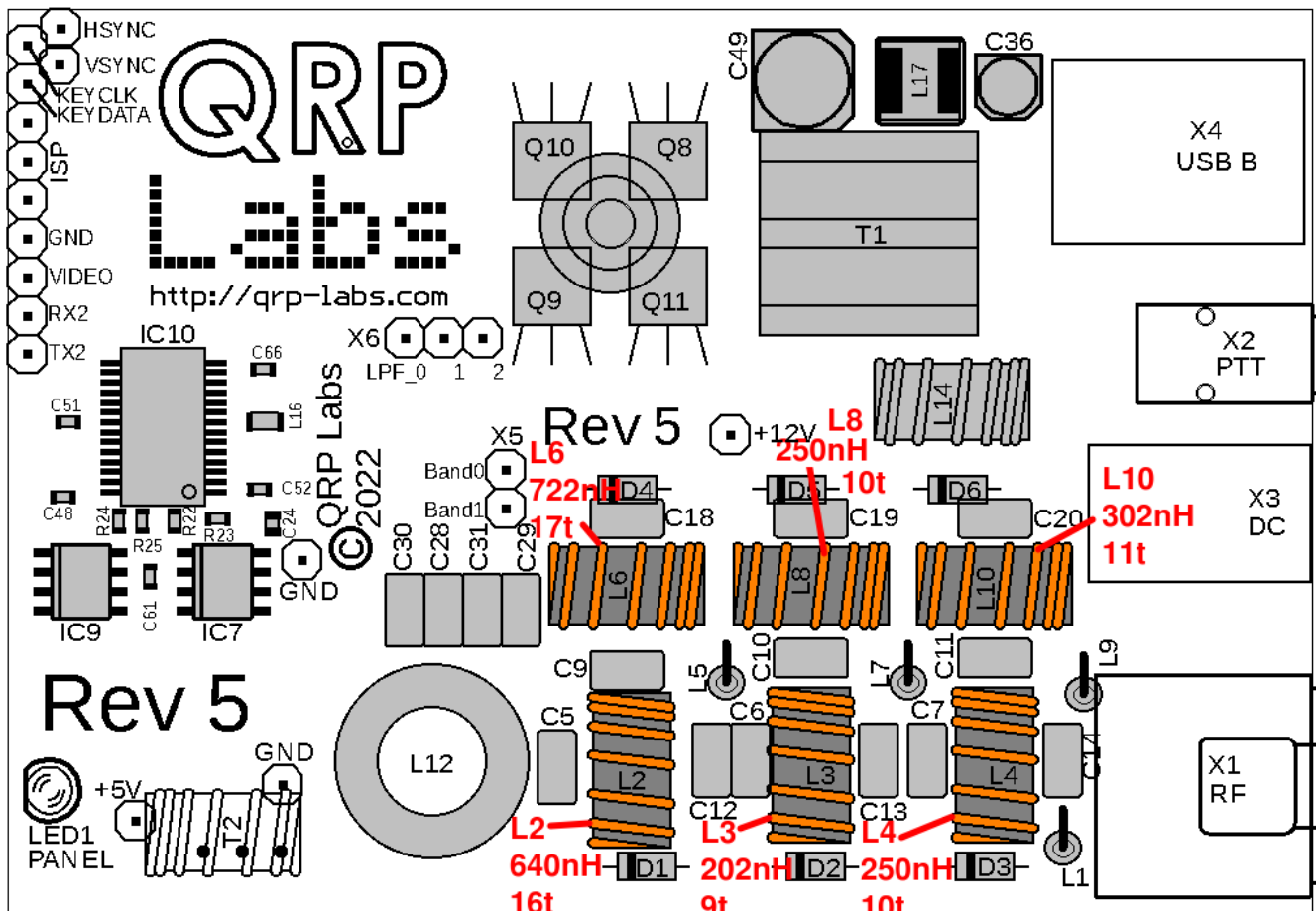

2.12 Wind and install trifilar toroid T2

This toroid needs some care so please follow these instructions very carefully.

Divide the remaining 0.33mm (AWG #28) wire into three equal lengths. These three pieces now need to be tightly twisted together to make the trifilar wire. My method for this is to tie one end in a knot around a small screwdriver shaft. Similarly tie the other end around another small screwdriver. Now clamp one end somehow to something solid. You could use a vise, if you have one. If you don't, then you have to get creative and think of something. Here I taped it to the edge of the desk. Now you can twist the screwdriver at the free end, repeatedly until you twist the three wires together thoroughly. You need to keep the wire under a little tension to keep the twists evenly spaced.

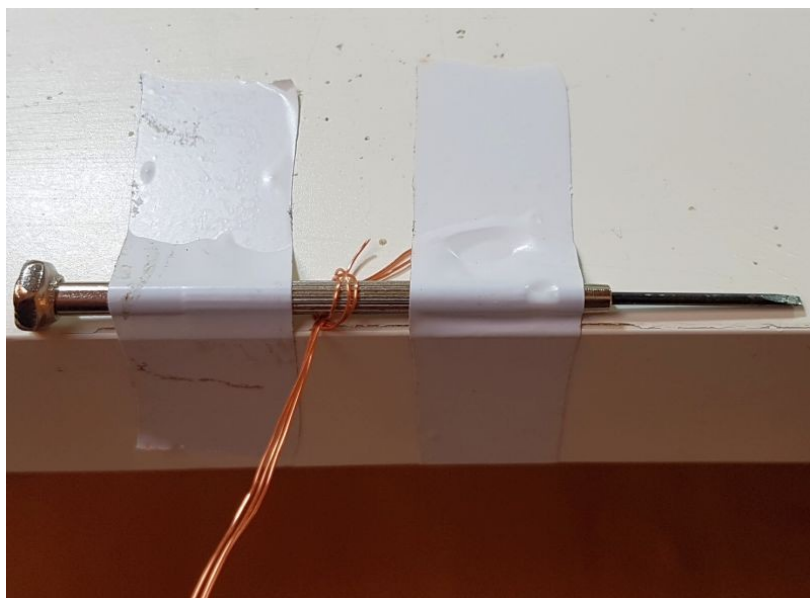
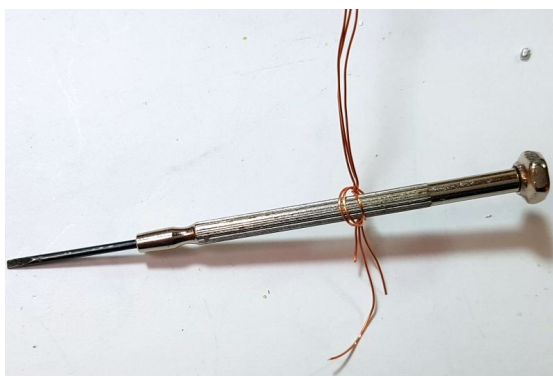
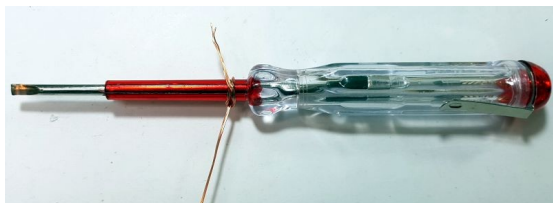

A 20cm length of wire should have about 60 twists. It is not critical.

The end result is something like the photo (right). The measurement scale is in cm.

Now cut off the untidy ends, and this is the piece of wire that will be used to wind the FT37-43 toroidal core as a trifilar transformer.



Hold the core between thumb and finger. Pass the wire first from above, to below. Then take the wire from below, and bring it around to pass through the toroid again to form the second turn. After each turn, ensure the wire is fitting snugly around the toroidal core. Wind 10 turns on the core. Each time through the toroid's central hole counts as one turn. Cut off the excess wire, leaving about 2.5cm remaining.

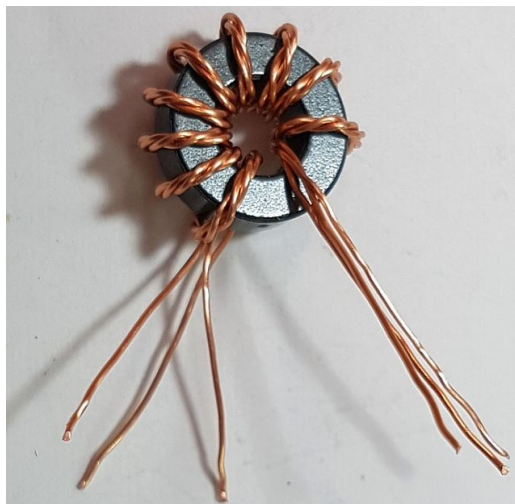
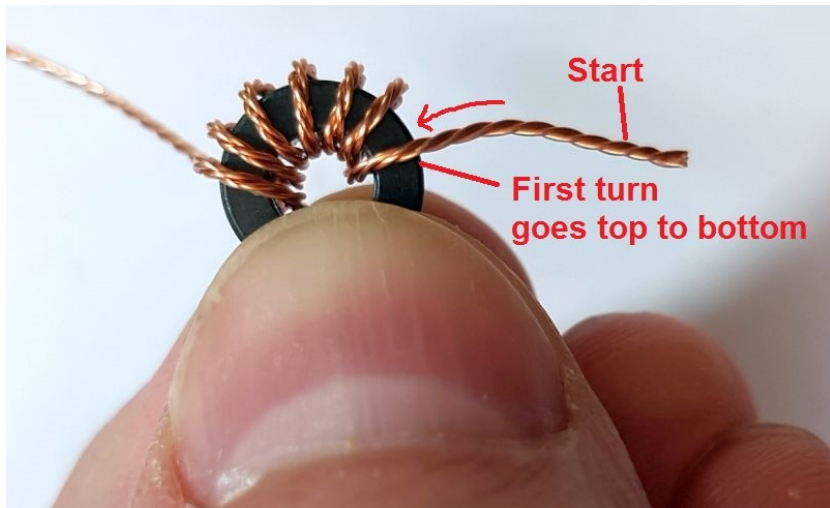

Now it's necessary to identify which wire belongs to which winding. You have three windings twisted together, they all use the same wire. The only way to do this is with a DMM as continuity tester. First, untwist and straighten the wire ends that are not wound around the toroidal core.

Now tin the last few mm at the ends of each wire. You can do this by scraping off the enamel then tinning with the soldering iron; or, if your soldering iron is powerful enough, hold the wire end in a blob of molten solder for a few (maybe 10) seconds, until the enamel burns off.

Now use a DMM to test for continuity. Re-arrange the wires so that there is continuity from A-A, B-B, and C-C in this photo.

Carefully keep this orientation of wires and insert the transformer this way into the PCB. BE CAREFUL not to lose the orientation of the wires! The right wires must be in the right holes, so that the windings are connected correctly in the circuit!

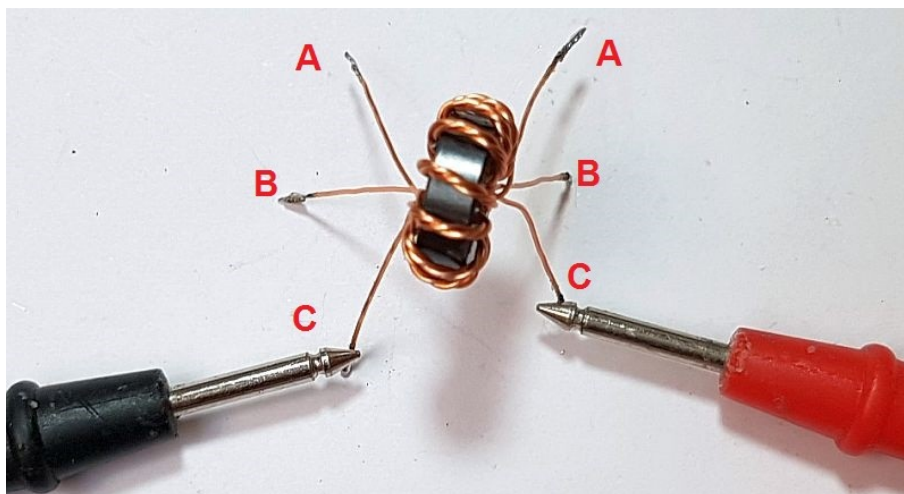

Refer to the diagram on the following page to see the correct orientation.

Once the wires are inserted through the correct holes in the PCB, and pulled tight, check for continuity between the pairs of wires in holes A, B and C once AGAIN. It is much easier to get this right first time, than it is to make repairs later!

Be sure NOT to solder any wire into the hole marked "GND"...

When you are satisfied that the wires are all in the correct holes, you can cut them to a length of about 2mm and solder them. It is best to cut-and-solder one wire at a time, since if you cut all the

wires to 2mm length then the toroid is more likely to fall out before you've had a chance to solder any of the wires. If that happens, it will be tough to get all the wires back in the correct holes again.

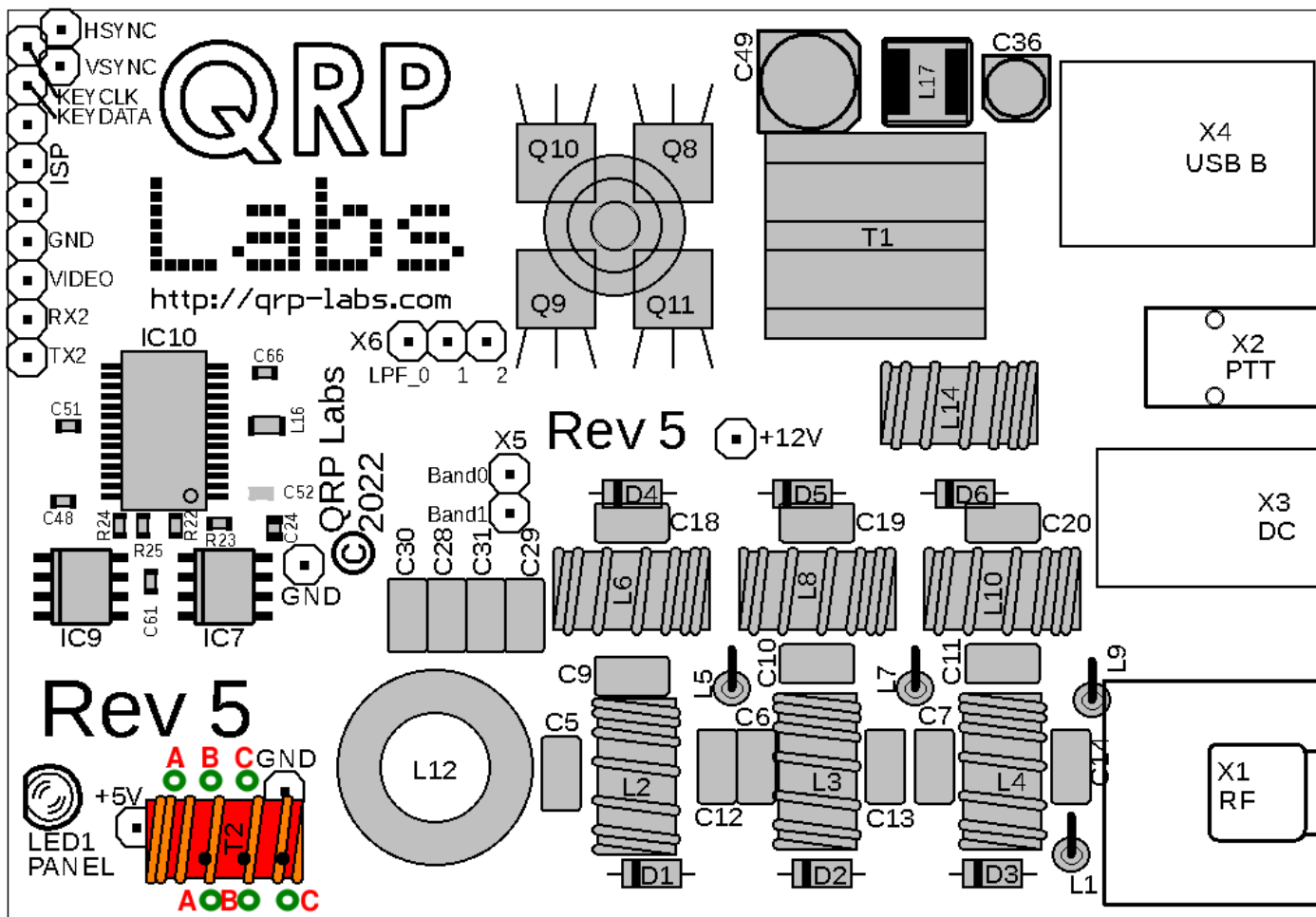

There are numerous SMD components in the vicinity so be VERY careful when soldering the wires of toroid T2, NOT to touch any of the nearby SMD components!

Once again my method involves holding the iron and plenty of solder on the joint for at least 10 seconds to make sure the enamel burns off completely.

The photograph (right) shows the trifilar wire ending holes labeled A B C on the lower side of the PCB. You should check for continuity between each pair of pins A-A, B-B and C-C; and the triplet of pins IC4 pins 7 and 9, and IC3 pin 7.

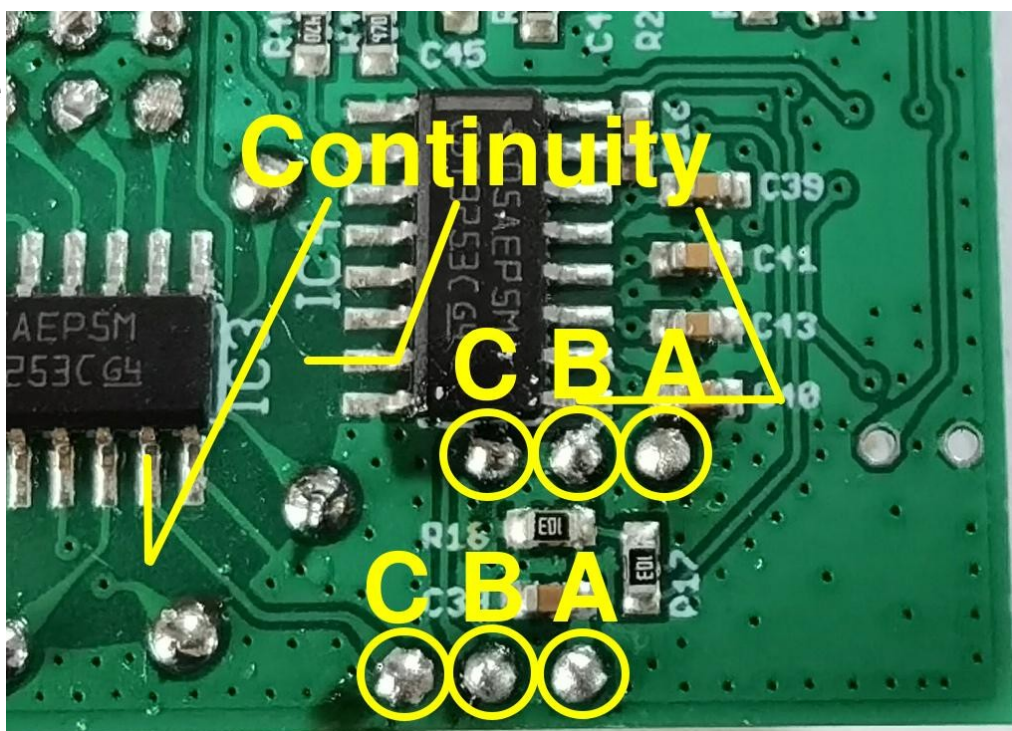

2.13 Install the 3mm red status LED

Identify the shorter of the two wires of the 3mm red LED and bend it 90-degrees right at the body of the LED.

Bend the other wire 90-degrees but at a distance of approximately 2.5mm (0.1-inches) from the body of the LED (see photograph, right).

Insert the LED leads into the holes in the PCB. As an additional check, the LED will have a flat part on its body, which will sit flat on the surface of the PCB. Solder the LED in place but be careful that it is accurately aligned in position, protruding over the board edge at right-angles. This will ensure that later if you are using the optional enclosure, the LED will fit without difficulty.

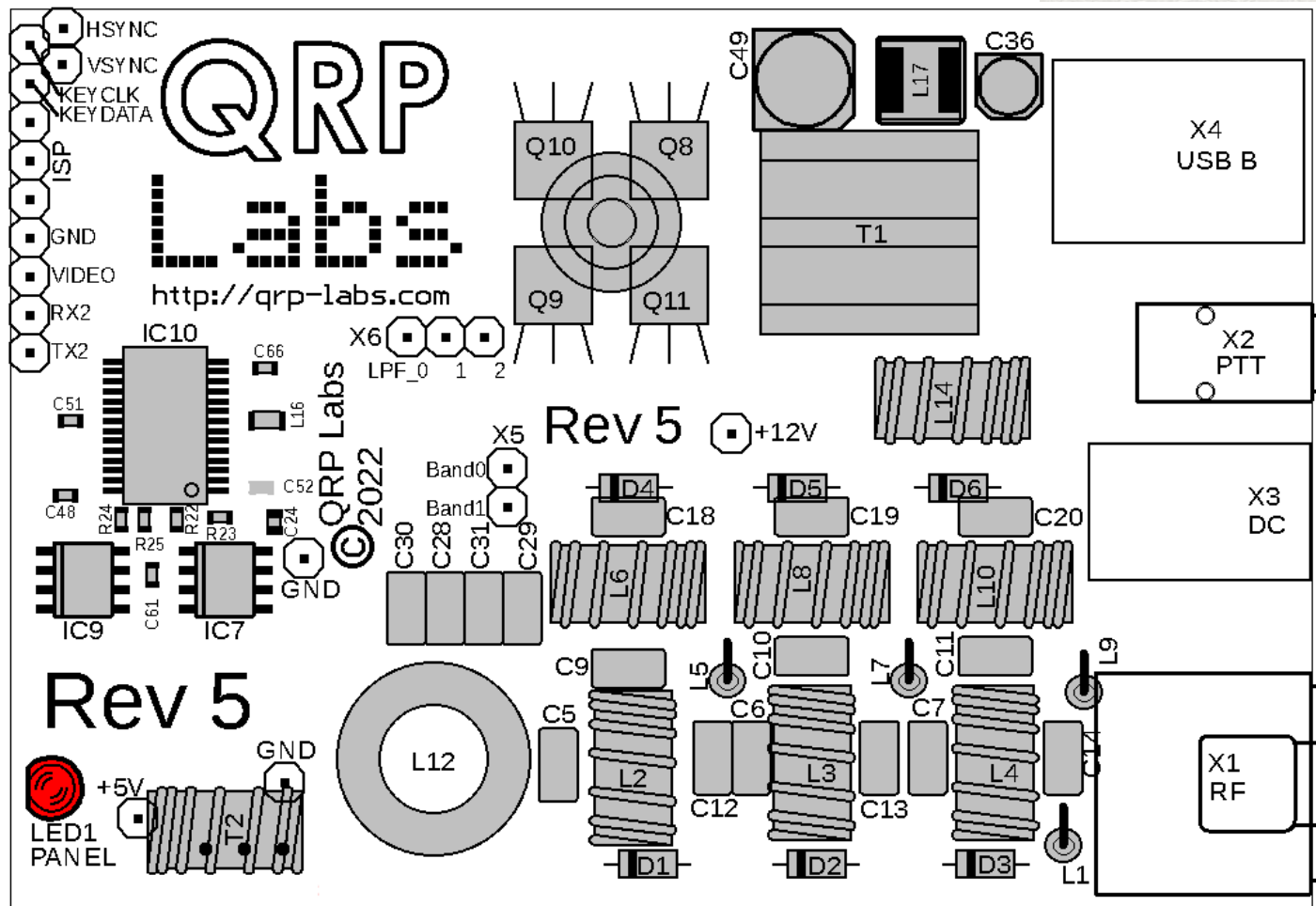
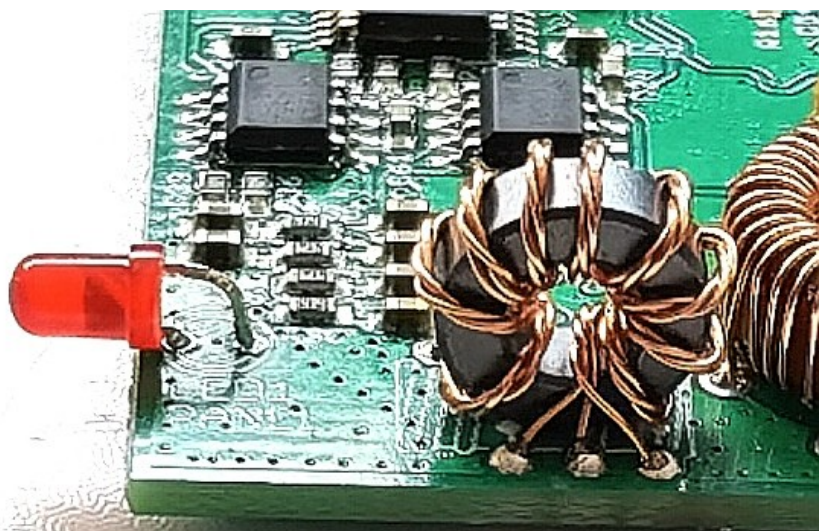

Photo (right) shows the LED installed correctly (Rev 3 PCB pictured)



2.14 Install jumper wire

For the 20 / 17 / 15 / 12 / 10m version only:

The jumper wire installation is necessary to inform the firmware to set up the band configuration parameters according to the correct defaults for the high-bands 20-10m version.

Just to the left of the BS170 power amplifier transistors is the QRP Labs Logo. Use a piece of component wire off-cut formed into an inverted 'U', and install it in the two holes which are above the 'b' and 's' of "Labs", as shown in the photograph below. Be sure to ignore the hole which is at the bottom of the 'P' of "QRP".

With this jumper wire installed, QDX will automatically initialize itself for high-bands operation.

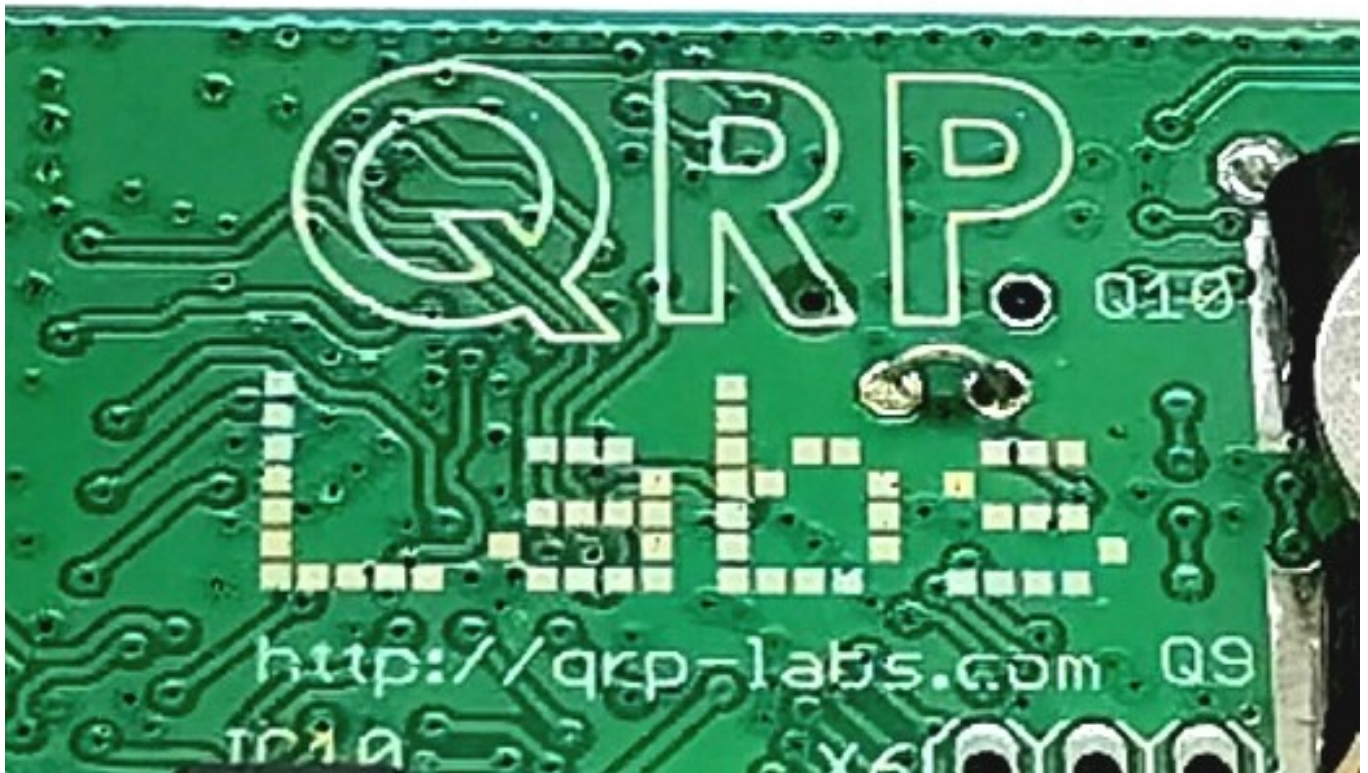

2.15 Install connectors

The final components to install are the connectors, from top right to bottom right:

- X1: USB B connector
- X2: DC Power connector
- X2: PTT (mis-named X2, should be X3)
- X4: BNC RF connectors – NOTE: there is a footprint for an SMA connector that you may install if you wish; however this will have gaps around it as it pokes through the enclosure.

It is very important to install these carefully aligned so that they are straight and at right-angles with respect to the PCB. The connector body should not protrude beyond the edge of the PCB. When the connectors are well-aligned, you will have no trouble fitting the PCB into the optional enclosure. Clip off excess leads and tabs to make sure nothing protrudes more than 1.5mm.

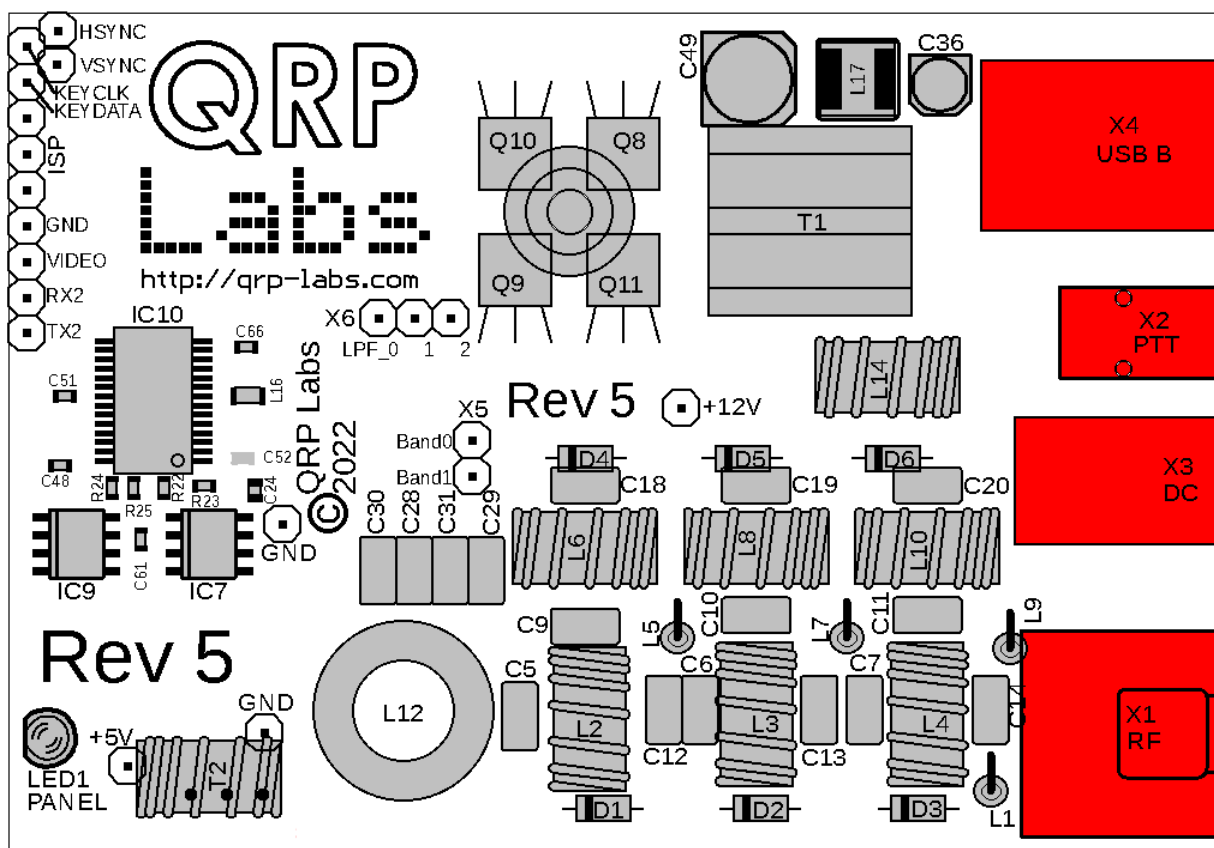

Assembly of the QDX kit PCB is now complete!

(Rev 4 PCB, 80/60/40/30/20m version shown).

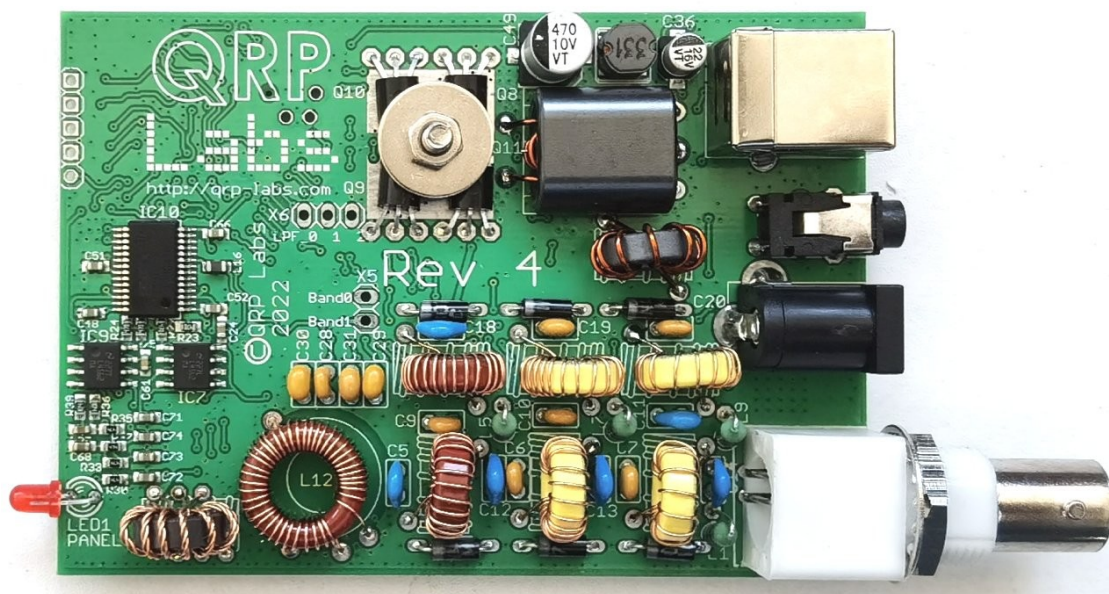

2.16 Optional enclosure

Installation of the QDX PCB in the optional enclosure is very straightforward and self-explanatory.

1. Install the screws at the bottom left and bottom right of the front panel, fixing it to the bottom half of the enclosure. Note that the enclosure top and bottom are identical.
2. If the short edges (front and back, i.e. LED status edge, and connectors edge) of the PCB feel rough, it can be a good idea to gently file them so that the PCB edge is square.
3. Gently slide the PCB into the guide-rail grooves in the enclosure bottom.



4. Install the two screws at the bottom left and bottom right of the rear panel, fixing it to the bottom half of the enclosure.
5. Fit the top half of the enclosure. Note that one side has an “I-tongue” and the other side has a “U-groove” and this is repeated on both halves (top and bottom) of the enclosure. Therefore the top half will only fit the bottom half, “one-way-round”. If it does not appear to sit correctly, rotate the top half 180-degrees. Secure the top with the remaining screws.
6. Finally you may, if you wish, fit the nut to the BNC connector. I generally leave off the washer. The nut may be omitted too, it is not really required and should in any event not be over-tightened since there is a small gap between the back surface of the rear panel, and the BNC connector body. The washer can be installed on BNC connector the INSIDE of the enclosure to fill some of that gap. It’s a matter of trying it out and seeing what fits best in your case and gives you a result you’re most happy with.
7. If desired, attach the self-adhesive rubber feet to the bottom of the enclosure in the corners.



3 Design

3.1 Summary

Traditionally it was normally assumed that transmission of digital modes requires a computer, to generate the audio tones, and an SSB transceiver, to modulate those to RF and transmit them via an antenna.

Yet – the widespread assumption that an SSB transceiver is REQUIRED is in fact absolutely incorrect, at least for a wide category of digital modes transmitting a single tone frequency shift keyed signal. This class of transmissions are NOT SSB, they are a single carrier, frequency modulated. Potentially this can provide simplification of the radio transceiver design, delivering both higher performance and lower cost.

Why is this important? An SSB transmitter design is necessarily relatively complex and a non-trivial undertaking for several reasons. The audio signal must be converted to RF by an SSB exciter. An exciter may commonly take the form of a superheterodyne architecture having a modulator, IF filter (crystals) and another mixer to convert to the final RF operating frequency. It then requires a linear amplification chain to raise the signal amplitude to the required power output at the antenna port. An alternative architecture is a phasing network exciter which makes use of phasing techniques to null the unwanted sideband, and converts directly from baseband to RF. Again it is followed by a linear amplification chain. In both cases considerable attention to the design is required, to minimize the residual carrier frequency, and the unwanted sideband.

Linearity must be maintained throughout the amplifier chain to the antenna port, to avoid splattering onto adjacent frequencies. Even though the audio signal is theoretically a single audio tone, harmonics of the audio tone may be present particularly if the audio level is too high, and the carrier suppression and unwanted sideband are never perfect; so there is plenty of potential for generation of intermodulation products, hence the need for good linearity throughout. A linear amplifier (for example, Class AB) has low efficiency compared to non-linear amplifiers such as Class C. Low efficiency means higher current draw for a given power output (less battery-friendly in portable scenarios), and higher heat production, probably requiring heatsinking of the PA transistors – increasing size, cost and weight.

Double Sideband (DSB) is even worse – the designs are simpler but here we have an equal amplitude unwanted sideband emission. Half the transmitter's power is wasted on this unwanted sideband, which potentially can interfere with users of adjacent channels. On receive, we suffer a 3dB degradation in noise floor at best, and at worst, interference from signals in the unwanted sideband. With the strong double tone (both sidebands) the potential for intermodulation products due to non-linearities in the amplification chain is higher. Except under optimal conditions, and even then with difficulty, two DSB transceivers cannot QSO with each other! A DSB transceiver can only QSO with an SSB transceiver at the other end. DSB is the only mode which cannot even communicate with itself! Some would say, an abomination of a mode.

If there were a way to convert the audio tones from the computer, to RF, without going through the SSB modulation process and linear amplification, it could solve many problems.

Back in 2012 the QRP Labs Ultimate QRSS/WSPR/Digi transmitter kit was the first kit to generate and transmit digital signals standalone with no PC required, and without an SSB transmitter. It used just a microcontroller calculating the required frequency shifts and commanding an RF signal generator – then the AD9850 Direct Digital Synthesis (DDS) chip – to produce the required frequencies. Several iterations of the kit evolved over the years, to the current Ultimate3S <http://qrp-labs.com/ultimate3/u3s> which can transmit quite a list of digital modes in the standalone beacon application.

However for QSO digital modes, using computer (PC) software to encode and decode the audio, SSB transceivers remained the norm.

In the second half of 2019, I was thinking about FT8, and a number of simple low cost FT8 transceiver kits that were available (DSB transceivers), none of which offered a particularly good performance. I realized that there IS a better way to do this, that will dramatically increase the performance without increasing the price. Straight away I designed QDX and built the prototype.

The fact that the computer is generating the audio, does not need to stop us from generating a single RF tone from an RF signal generator, just as the Ultimate3S QRSS/WSPR/Digi kit does. A microcontroller can analyze the audio arriving from the PC, and determine the audio frequency of the tone; then add that to an RF base frequency (which on an SSB radio, we would call the “USB Dial Frequency”), to determine the correct RF carrier frequency to generate for transmission. The rest is then a matter of commanding an RF generator to produce the calculated frequency, and amplifying it for presentation to the antenna. The generated signal is absolutely clean, having only harmonically related unwanted spurious emissions which can be taken care of in the conventional way by Low Pass Filtering.

The importance of this technique cannot be understated.

- We no longer need a complex SSB modulator involving multiple mixers, IF filters (or phasing in the case of the direct method).
- No more linear amplification chain – we can use higher efficiency non-linear amplifier classes, reducing the need for heatsinking, and lowering transmit current, very battery friendly.
- The unwanted sideband simply DOES NOT EXIST. It isn't just “there but attenuated” depending on how well the transceiver was designed and aligned - it just isn't there at all.
- Similarly the carrier also does not exist. Carrier suppression in a modulator depends on how well the mixer is balanced and is never perfect. But here, we generate a single tone directly – and there's NO SSB carrier at all. Zero.
- It is impossible to overdrive this design by turning up the audio volume too high on the PC. Therefore it is impossible to generate a messy signal that splatters on to adjacent frequencies.

With this in mind, the rest of the QDX transceiver design falls into place, around this central concept.

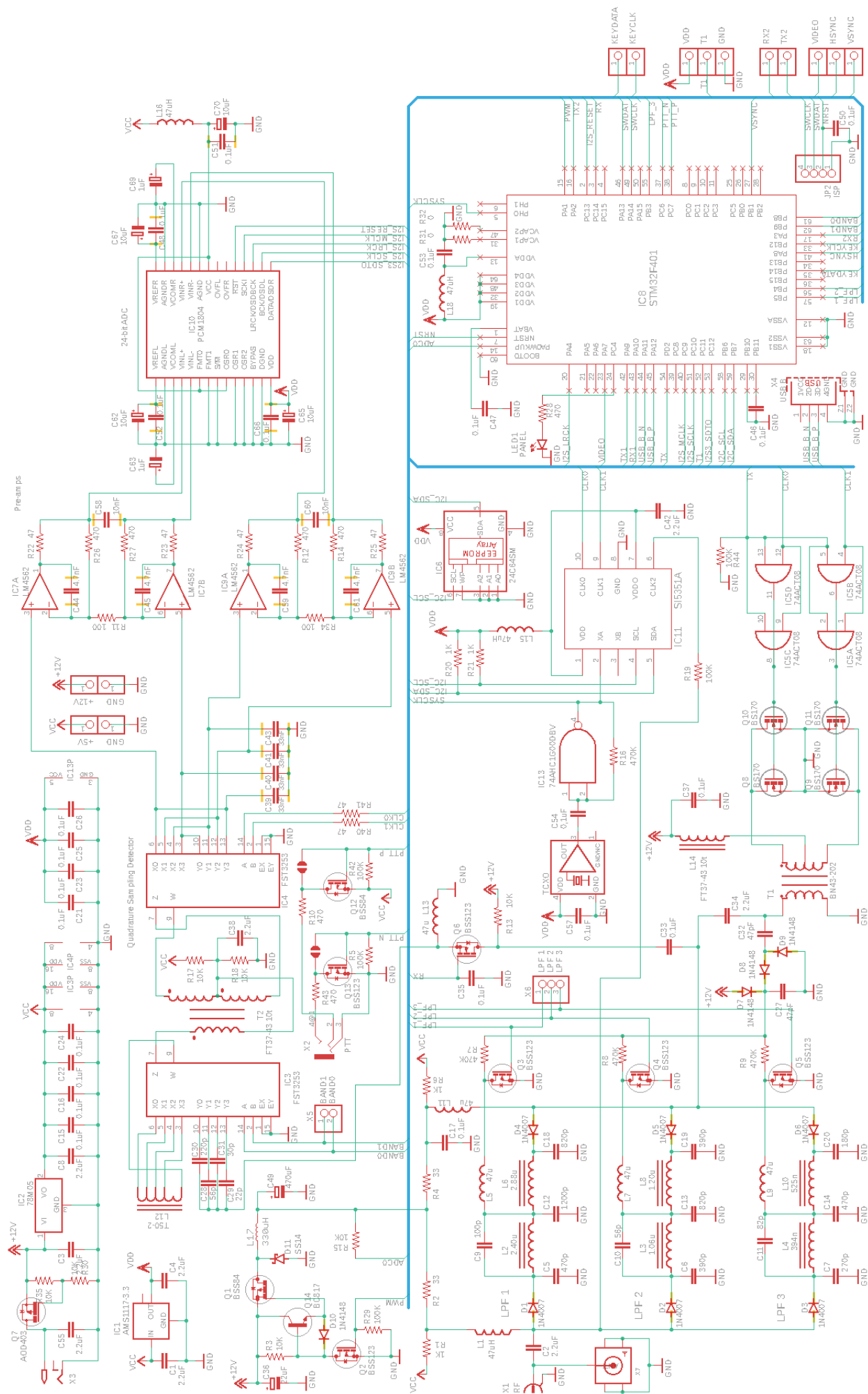

3.2 Block Diagram

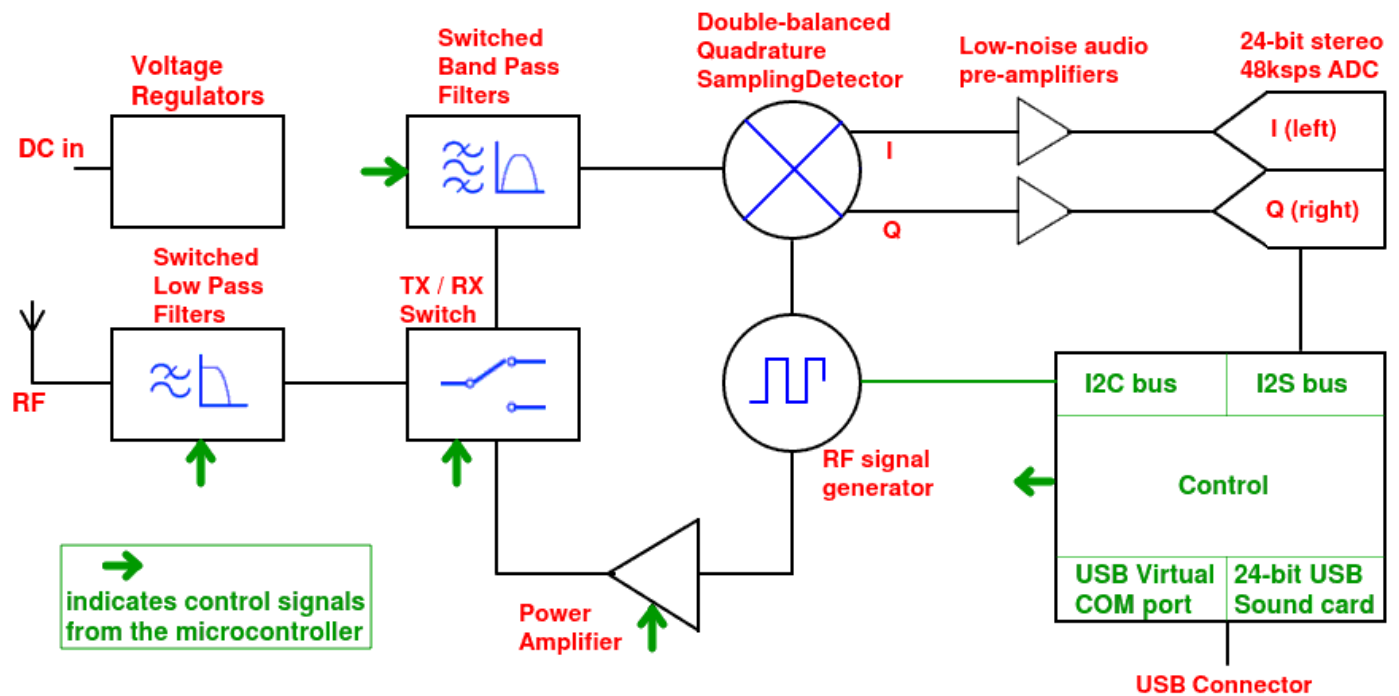

QDX consists of the following circuit blocks:

1. A synthesized Local Oscillator using the famous Si5351A Digital PLL signal generator chip. A 0.25ppm 25MHz TCXO is included as standard as the PLL reference.
2. Low Pass Filtering to attenuate emissions at harmonics of the operating frequency. Filters are provided to cover 80, 40, 30 and 20m bands, and selected using solid state, PIN diode switching.
3. A solid state transmit/receive switch – no bulky, noisy, expensive, unreliable relays here!
4. A switched receiver band pass filter to provide some degree of protection to the mixer against out of band signals.
5. A high performance, double balanced Quadrature Sampling Detector to mix the incoming RF signals to baseband and produce I and Q signals.
6. A low noise pre-amplifier for the I and Q signals.
7. High performance 24-bit 48kps (Kilo Samples Per Second) stereo Analog To Digital Converter (ADC) chip with 112dB of dynamic range.
8. An embedded Software Defined Radio (SDR) receiver which implements, digitally, a 12kHz Intermediate Frequency superheterodyne receiver with excellent performance and unwanted sideband suppression, also implementing a sharp digital filter.
9. An embedded 24-bit 48kps stereo USB Sound card – no more noisy, cluttered audio cables!
10. A CAT control serial interface, also over the same USB cable, to allow the PC software to control the radio (frequency, transmit/receive switching etc) in a standard way.
11. The microcontroller performs single cycle frequency analysis of the audio tone, and commands the Si5351A Signal generator to produce the necessary RF frequency.

12. A Class-D Push-Pull power amplifier that is small, low cost, high efficiency, and produces very low even harmonic output levels, reducing the demands on the Low Pass Filter.

13. Voltage regulation and supply decoupling.

In subsequent sections, each of these blocks will be described in detail.

3.3 Synthesized local oscillator

Generating a stable, precise oscillator signal was one of the most challenging aspects of transceiver design. Modern semiconductors however, make it one of the easiest building blocks of the radio.

The synthesizer used in the QDX is the same as in the QCX 5W CW transceiver, and various other QRP Labs products: the Si5351A. This is a Digital Phase Locked Loop (PLL or DPLL) synthesizer which provides three separate frequency outputs, each having a frequency range spanning 3.5kHz to 200MHz. The frequency stability is governed by the a crystal reference.

Due to unavailability of the Si5351A, the equivalent MS5351M may be used. For test details on the performance of Si5351A vs MS5351M demonstrating the suitability of the MS5351M (in fact, slight superiority in many regards), please see <http://qrp-labs.com/synth/ms5351m.html>

The block diagram (right) is taken from the SiLabs Si5351A datasheet. Briefly, the 27MHz reference oscillator is multiplied up to an internal Voltage Controlled Oscillator in the range 600-900MHz (the PLL), then divided down to produce the final output frequency. The multiplication up and the division down are both fractional and so the frequency resolution is extremely finely controlled. The chip has two PLLs and three output divider units.

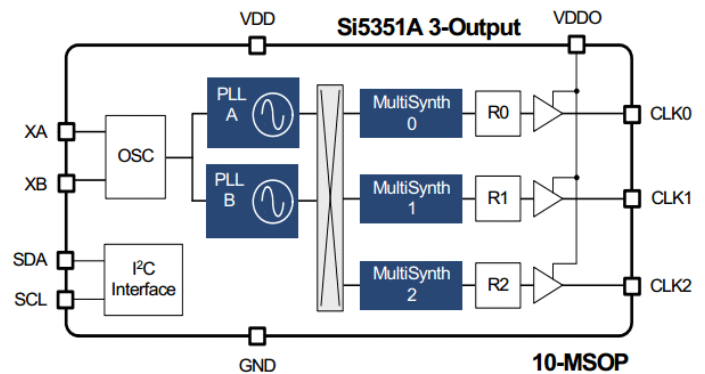

For best jitter performance, the Si5351A datasheet recommends the use of even integer dividers (no fractional component) in the MultiSynth dividers and in the QDX transceiver design, this recommendation is followed.

The Si5351A datasheet dictates the use of a 25 or 27MHz crystal or oscillator. In the QDX a 25MHz crystal was originally used, together with an unusual NPN/PNP transistor oscillator circuit, which produces a near rail-to-rail (3.3V peak-peak) output that is perfect for driving both the Si5351A and the STM32 processor. However on Rev 3 of the PCB, layout changes caused high inductive loading on the 25MHz signal. During transmit the synthesizer was found to suffer momentary loss of PLL lock, causing discontinuities in the transmitted signal which sounded like “pops” when monitored on a different radio receiver.

The “popping” was fixed via a firmware update (1_04) however this effectively hid the pops, rather than cured the root cause. In 1_04 the “pops” are so infrequent as to be virtually undetectable.

The actual root cause is that the Si5351A is very sensitive to the waveform driving it on pin 2. According to the datasheet, a 1Vpp signal should be used. However in practice this is found to be incorrect; a larger signal is frequently required, to ensure no loss of lock (“pops”). In Rev 4 of the PCB, a single NAND logic gate chip is used to buffer the 1.1Vpp signal from the 25MHz TCXO to a 3.3V squarewave. This completely cures the “pops”.

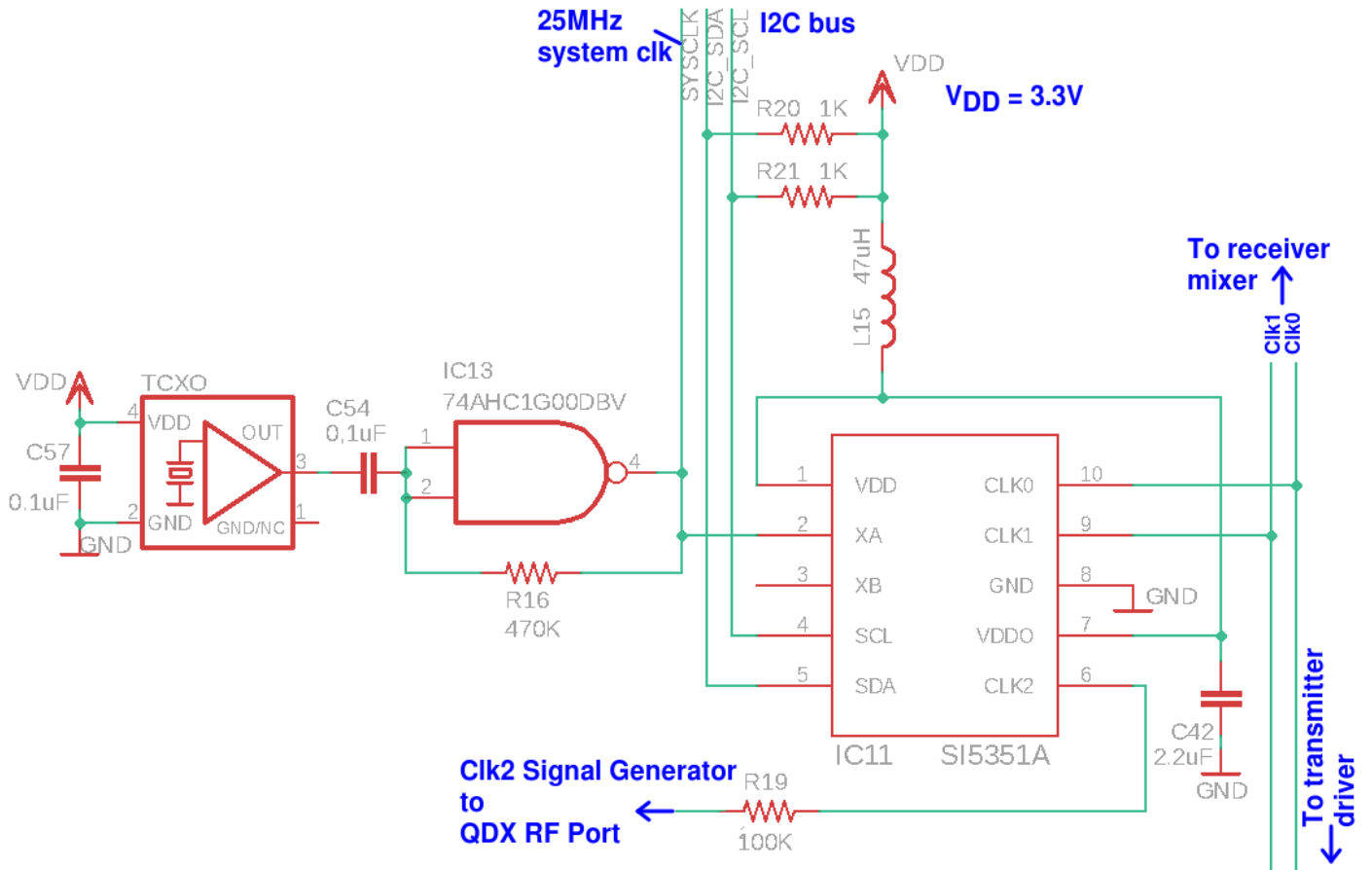

During testing, the original 25MHz push/pull crystal oscillator was found to provide an unsatisfactory level of frequency stability, which was very disappointing and boards had already been ordered. In the graph below, an example operating session is shown. QDX was operated on the 20m band and the operating frequency was monitored as an audio tone on a separate receiver. 20m was used as it is the highest frequency of operation of QDX and would therefore illustrate the worst-case scenario. The nominal operating frequency was 1kHz audio and was not altered during the test.

In the graph, the red line is the audio frequency. The blue line is the output of the STM32's internal temperature sensor ADC input. It is uncalibrated (to temperature), and just indicates relative temperature changes.

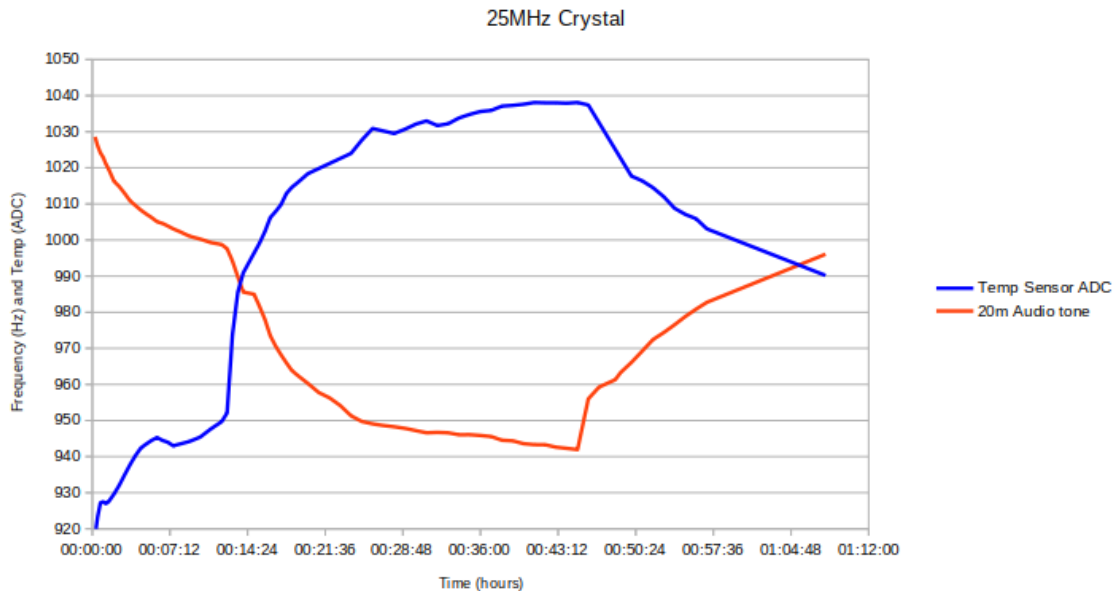

The QDX was switched on at 00:00 on the left side of the graph. An initial warm-up drift of 30Hz downward drift can be seen (red line). At around 12 minutes, FT8 operations were commenced, having the usual 15 second slots with alternating transmit and receive cycles, resulting in a duty cycle a little under 50% (FT8 transmissions are a bit less than the 15 second cycle). FT8 operations ceased at around 47 minutes, by which time the enclosure had warmed up considerably and the frequency had dropped almost 90 Hz from power-on! As the unit cooled down, the frequency drifted back upwards again. The temperature curve (blue) gives a relative indication of the temperature of the PCB.

FT8 has a bandwidth of about 50Hz. You can see that a 90Hz drift in half an hour of operation is rather unacceptable! Anybody who has tried FT8 operation will know that the band is usually full of QSOs and you struggle to find a clear spot to transmit in, often slotted in with other stations closely on either side. With such a bad drift rate, you would drift right across the other stations' transmissions – or to avoid that, have to keep making little adjustments to the operating audio frequency in WSJT-X to counteract the drift! Horrible!

The problem was resolved in the first QDX batch by designing a neat little PCB containing a 25MHz TCXO that is fit to the QDX during assembly, INSTEAD of the 25MHz crystal.

In subsequent PCB revisions the 25MHz TCXO is already mounted on the main PCB.

The output amplitude of the TCXO is 1.1V peak-peak which is enough for the Si5351A, but insufficient to drive the STM32 oscillator input. It was therefore buffered using the original NPN/PNP transistor crystal oscillator circuit, which resulted in a rail-to-rail (3.3V peak-peak) near-square wave.

After fitting the TCXO in place of the original 25 MHz crystal, the drift is reduced to +/- 1Hz or so which is unnoticeable and entirely acceptable.

In summary:

PCB Rev 1: NPN/PNP 25MHz crystal oscillator suffered frequency drift, and a retrofit 25MHz TCXO daughtercard was supplied, fitted in place of the 25MHz crystal, to solve the drift problem. The same NPN/PNP push-pull circuit now functioned as a signal buffer.

PCB Rev 2: The 25MHz TCXO is fitted as standard on the PCB (no longer a daughtercard).

PCB Rev 3: PCB layout changes to accommodate the PCM1804 ADC chip and differential drivers was thought to result in increased parasitic capacitance and inductance, loading the 25MHz signal and reducing the signal amplitude slightly. Random loss of PLL lock occurred, causing “pops” when the signal was monitored on a receiver; firmware 1_04 hid this problem by finding different ways to configure the Si5351A that made PLL lock loss very rare.

PCB Rev 3a: As per Rev 3 above.

PCB Rev 4: NPN/PNP buffer circuit changed to a single logic gate NAND chip buffer, resulting in clean 3.3Vpp squarewave that completely solves the “popping” issue at source.

The Si5351A has a large number of internal 8-bit registers to control the synthesizer configuration and output frequency, and these are programmed by the microcontroller using the I2C serial protocol. 1K resistors R20 and R21 are pull-ups required for the operation of the bus at 400kHz.

There are three outputs of the Si5351A synthesizer and these are all used to good advantage. The Clk0/1 outputs are used to drive the Quadrature Sampling Detector (QSD) during receive.

A feature of the Quadrature Sampling Detector is that either the RF input, or the LO input, must provide two paths in 90-degree quadrature. This is normally applied at the Local Oscillator where it can be easily controlled for best performance. So, two oscillator signals are required, with the same frequencies but a precise 90-degree phase offset. Generating this quadrature Local Oscillator signal is always difficult. Analogue phase shift circuits have limited accuracy. Often a divide-by-4 circuit is used, to produce quadrature oscillator outputs from an oscillator input at 4x the reception frequency. This also creates challenges particularly as you try to increase the reception frequency to cover higher bands. For example, on 10m e.g. 30MHz, a local oscillator at 120MHz is required and the divide-by-4 circuit must be able to operate at such a high frequency. Devices such as the 74AC74 can do so, but pushing it higher into the 6m band cannot be done with the 74AC74.

The Si5351A has a phase offset feature, which is not really very clearly described in the SiLabs documentation. However, QRP Labs has perfected the technique to put two of the Si5351A outputs into precise 90-degree quadrature, which is maintained without tuning glitches as the frequency is altered. It's a nice development because it eliminates one more circuit block (the 74AC74 divide-by-4 circuit), again reducing complexity and cost. To the best of my knowledge this is the first time the Si5351A has been implemented in a product directly driving a QSD with two outputs in quadrature (no divide-by-4 circuit).

The Clk0/1 Si5351A outputs are also routed to the transmit driver. During transmit, Clk0 and Clk1 are configured with a 180-degree phase difference, this allows them to cleanly drive the QDX RF power amplifier, which is a Push-Pull configuration. It's a very neat way to obtain the necessary push-pull driver signals in a highly symmetric and low parts-count way.

Finally the Clk2 output is used as a separate signal generator, it is routed back to the QDX transceiver's RF port via the 100K resistor R19. This signal generator can be used by the QDX diagnostic and self-performance measurement tools, to sweep the audio filter and sweep the RF bandpass input filter. Clk2 is normally switched off, and when these functions are needed, it is enabled in conjunction with Clk0/Clk1 operating the receiver mixer.

An additional function of the 25MHz TCXO and its NAND gate buffer amplifier, is to provide the precise 25MHz system clock for the STM32. The STM32 microcontroller contains its own internal PLL clock generation systems that are highly configurable. In QDX, the 25MHz reference oscillator is fed to the STM32 external clock input, and the STM32 is configured to provide:

- 24.576 MHz clock for the 512 fs input to the 24-bit stereo I2S ADC chip ($24.576 / 512 = 48,000$) – fs is the number of clock pulses for each analog to digital conversion.
- 48 MHz clock for the STM32's USB peripheral to enable it to provide USB functionality for the USB sound card and the CAT Virtual COM serial port.
- 72 MHz for the main CPU clock

None of these signals are absolutely precise but they are very close to the target values and well within specified allowable errors for the protocols involved (USB, I2S). The 72 MHz CPU clock is a little below the maximum allowable 84 MHz for this processor, but this is acceptable since the performance at 72 MHz is plenty adequate to achieve all desired functionality for QDX.

3.4 Solid state transmit/receive switch

During transmit, the receiver must be disconnected from the RF port of QDX because a 5W signal is 45V peak-peak which would be too much for the receiver input mixer IC3.

A spectacularly high “Off” isolation is not required, only sufficient attenuation to protect the mixer. During transmit, the Digital Signal Processing of the I & Q channels is suspended and there is no audio output of the receiver. In the QDX application a totally clean click-free transition between Receiver and Transmit states is not needed – a welcome relaxation compared to the demands of a CW transceiver.

The transmit/receive switch is implemented by a single BSS123 MOSFET. The source is at DC ground (via 47 uH inductor L4). The control signal from the microcontroller switches the MOSFET on or off. Capacitor C35 close to the MOSFET gate is found to be necessary to prevent inductive pickup of the 5W RF from partially switching on the MOSFET.

During receive, the transmitter drivers are all at zero potential, so the transmitter power amplifier transistors are in a high impedance state and do not affect the receive operation.

This simple transmit/receive switch very conveniently avoids the need for relays. Relays may be great for some applications but if a relay was used here for transmit/receive switching it would add bulk, weight, cost, and reduce reliability.

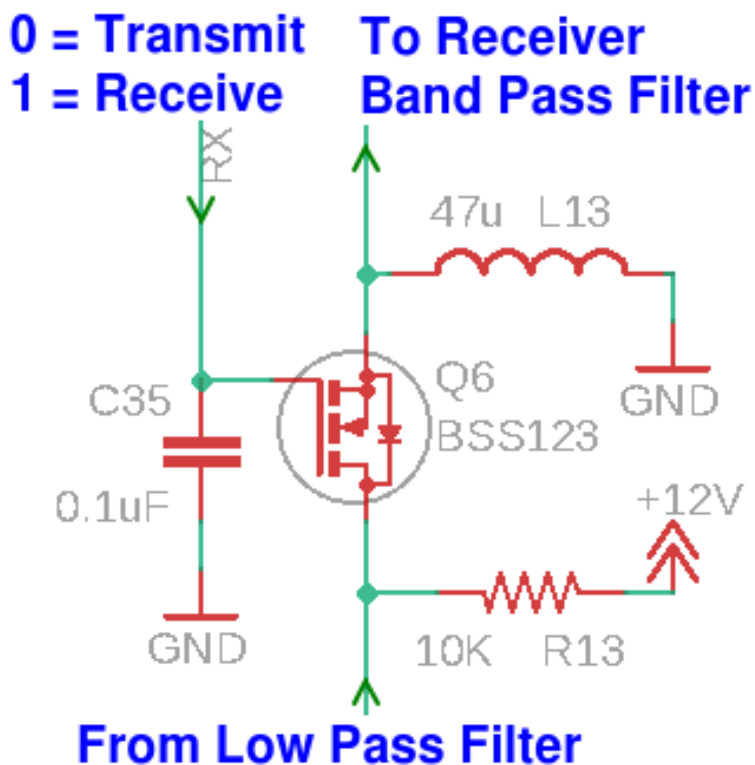

3.5 Switched receiver band pass filter

In any receiver, performance is improved by excluding strong out of band signals using a band pass filter. In QDX a rather simple series resonant L-C filter is used, which although limited, still provides some useful protection to the mixer. The mixer is a Quadrature Sampling Detector which is a high dynamic range, high IP3 mixer and therefore has excellent intermodulation performance. Together, the BPF and QSD provide a high performance receiver front end.

The band selection switch is a FST3253 dual 1:4 analog multiplexer IC, containing in other words, two 4-way switches.

The switch connects one of Y0 to Y3, to the W pin; and at the same time one of X0 – X3 to the Z pin. The selection of which of the four possibilities is connected, is made by two control lines named A and B (pins 14 and 2 respectively) which are connected to output pins of the STM32 microcontroller.

The Y-W switch connects one of capacitors C29, C31, C28 and C30 (for 20, 30, 40 and 80m respectively) to pin 9 (W).

The second switch X-Z then selects one of four taps of inductor L12.

Inductor L and capacitor C values are chosen such that the LC resonance is centered on the digi modes section of each band.

The whole BPF is DC-biased to 2.5V midrail via the trifilar phase splitting transformer T2 of the Receive mixer.

More sophisticated Band Pass Filters could be used but would come at the expense of complexity, board area, and cost.

NOTE

The Fairchild FST3253 is no longer manufactured in the 16-pin SOIC package, it is only available in the much smaller 16-pin TSSOP packaging. Texas Instruments produce an equivalent device, the 74CBT3253C which is still produced in 16-pin SOIC packaging; this TI version is used on current PCB revisions of the QDX. In this technical description, the old part number FST3253 is used.

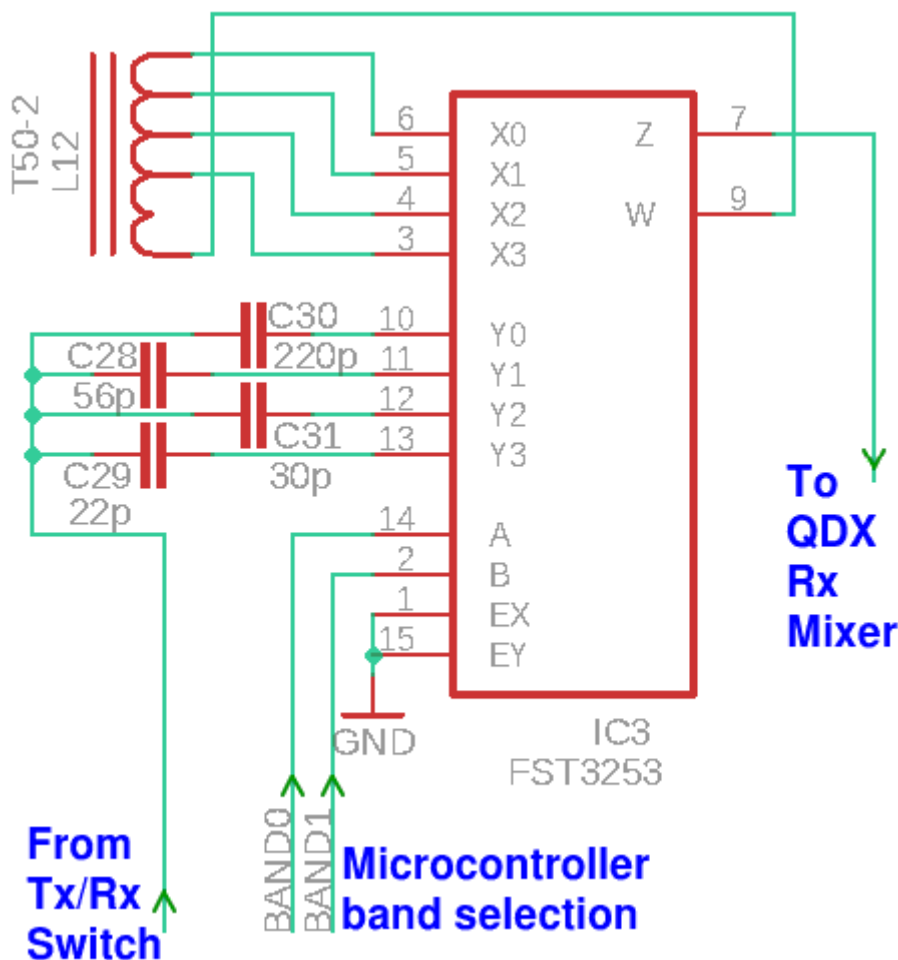

3.6 Double-balanced Quadrature Sampling Detector

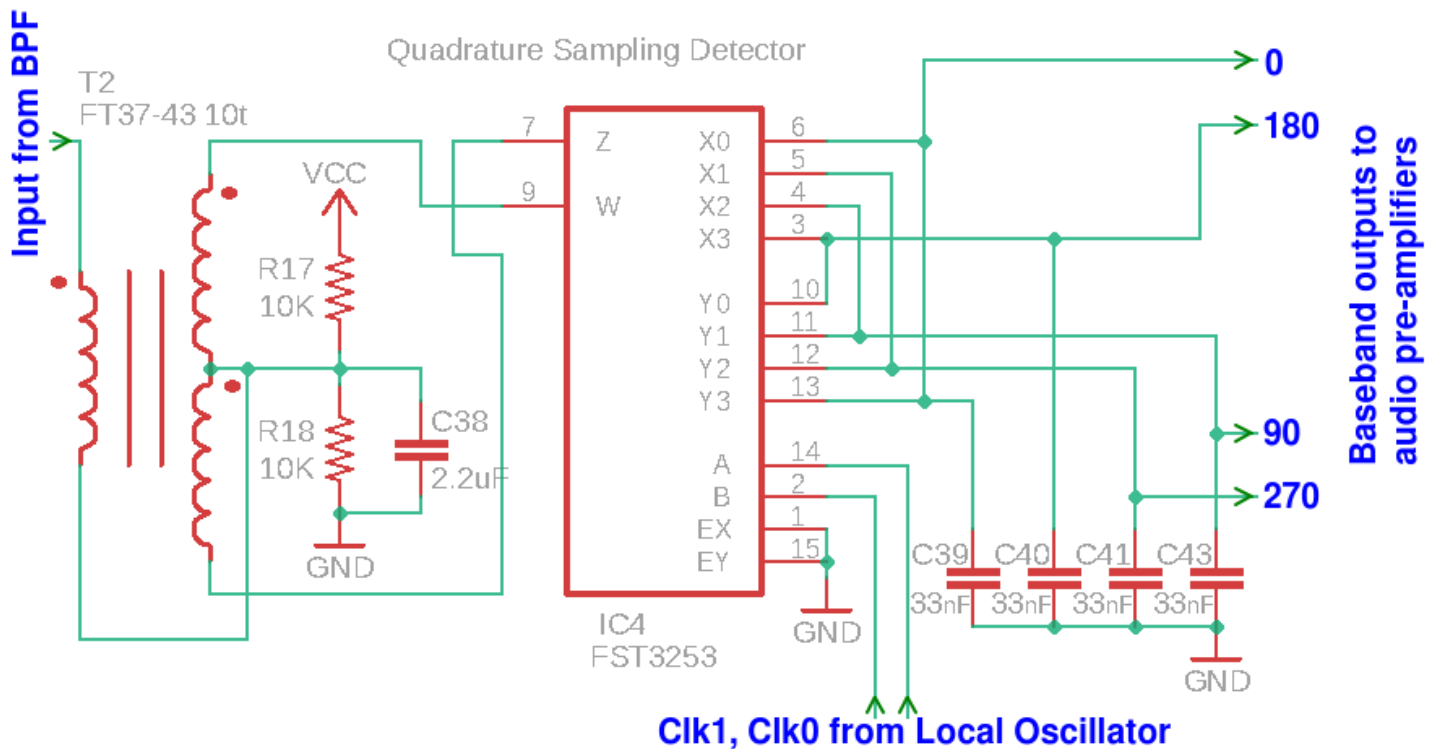

This circuit implements a double-balanced Quadrature Sampling Detector, mixing from RF to baseband. The FST3253 is a dual 1:4 multiplexer which is often seen in QSD circuits. It has fast switching times and very low on resistance of only a few ohms. The input signal is switched by the quadrature LO to each of the four integrating capacitors C39, C40, C41 and C43 in turn, for 90-degrees of the RF cycle each. The result is that the audio difference (beat) between the RF input and LO input appears across each of the four integrating capacitors, with four phases at 0, 90, 180 and 270 degrees.

The 33nF capacitors and the low source resistance results also provide a relatively fast roll-off of the audio response. This is effectively a narrow band pass filter since any incoming RF more than a few 10's of kHz away from the LO frequency is greatly attenuated. The QSD is inherently a very high performance mixer design with high third order intercept and dynamic range, and low loss (0.9dB).

The FST3253 dual switch is often connected with the two switches simply paralleled together (which does halve the switch ON resistance). But I prefer the double-balanced mixer configuration which provides higher performance. The double-balanced configuration requires two RF inputs 180-degrees out of phase (opposite to each other). This is provided here by trifilar-wound transformer T2.

R17, R18 and C38 provide a 2.5V DC bias to the RF signal through the mixer and audio pre-amplifiers. It also provides mid-rail DC bias to the Band Pass Filter component switches in the previous section. This simple bias does not source or sink any significant current due to the balanced nature of the system, therefore no buffering is required.

Note that the Clk0 and Clk1 signals from the local oscillator have 47-ohm resistors in series; some people say this reduces ringing artifacts in the detector though I have not been able to find any evidence for this.

3.7 Low noise balanced differential pre-amplifiers

The same LM4562 dual operational amplifier chip is used in QDX as is used in the QCX-series CW transceivers and QRP Labs receiver module. This is a low noise op-amp providing an excellent combination of high performance and low cost.

Low noise is important for the pre-amplifier because it determines the overall sensitivity of the receiver (in conjunction with losses of the RF front end).

This part of the circuit was substantially redesigned for the Rev 3 QDX PCB, due to the fact that the formerly used AK5386 ADC chip had become obsolete. The chosen replacement, PCM1804 claims even higher performance than the AK5386 but the PCM1804 has a differential input. One input could be ignored, feeding the I and Q signals into only one terminal of each ADC (left and right); however, this would sacrifice 6dB of the potential 112dB claimed dynamic range of the PCM1804.

The circuit used here is derived from the instrumentation amplifier topology that usually has three op-amps; the third op-amp being a unity-gain difference amplifier of the outputs of the first two. An instrumentation amplifier arrangement brings several key benefits in this application:

- Excellent balance means common mode noise signals are canceled out
- Very high input impedance makes the loading on the Quadrature Sampling Detector capacitors very light, as well as balanced
- Provides positive and negative phase I and Q signals suitable for feeding the differential PCM1804 ADC chip

The disadvantage is that we require twice the number of op-amps and more resistors and capacitors – but you know what they say about free lunches.

In the circuit shown above, the ADC chip itself, having differential input, performs the difference function so no 3rd op-amp is required in the instrumentation amplifier. The “Common” input was used with a resistor network to provide DC bias to the instrumentation amplifier inputs. However it was found that in circumstances the LM4562 op-amps could “lock up”, particularly IC7, with its output near the supply rail. On Rev 4 PCBs the DC blocking capacitors were shorted out post-production; on Rev 5 and above, the DC blocking capacitors and the bias network are removed completely; the DC mid-rail bias is fed through all the way from T2.

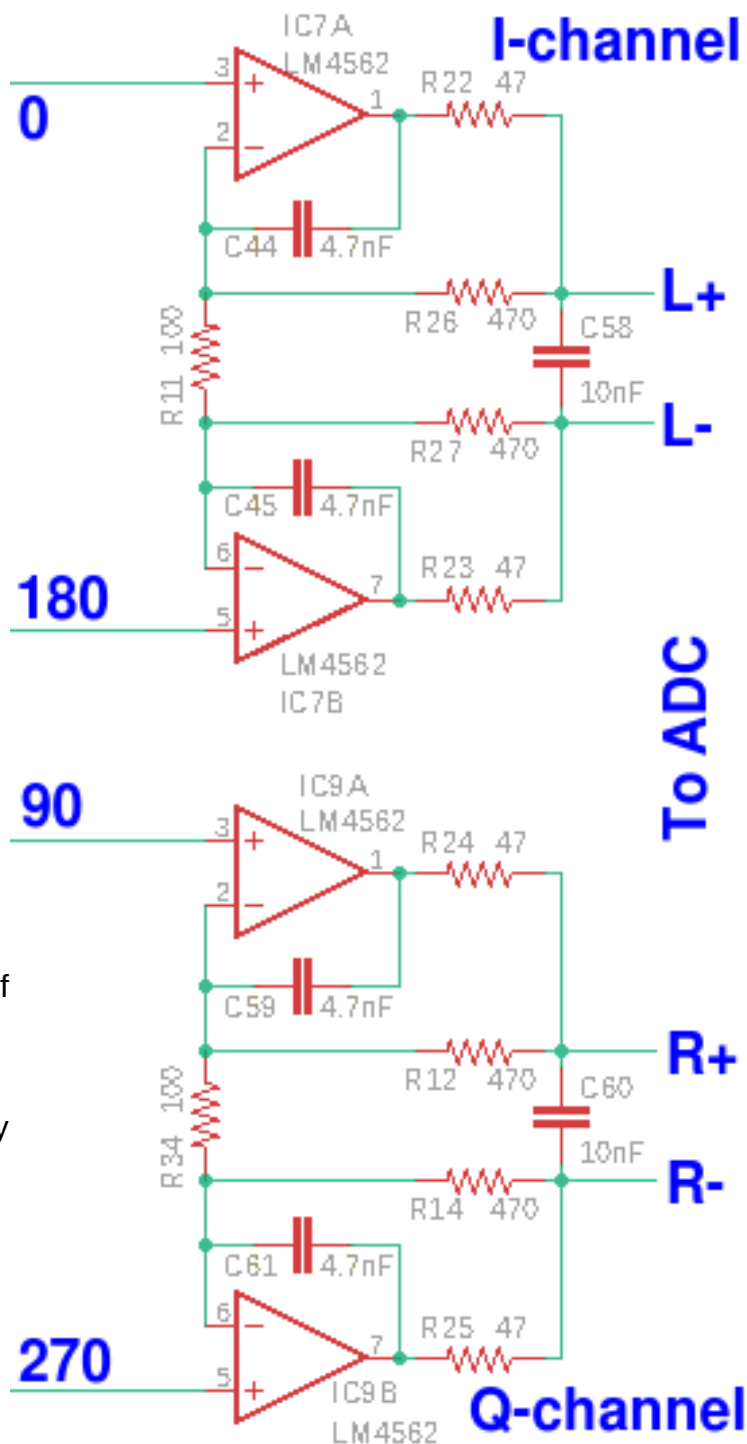

The 4.7nF capacitors provide high frequency attenuation beyond the 48kHz sampling bandwidth. The 10nF capacitors C58 and C60 are recommended by Texas Instruments in the PCM1804 datasheet and who am I to argue.

The gain of the instrumentation amplifiers is only about 20dB and is chosen to best match the dynamic range of the PCM1804 ADC in the application.

The I and Q channel contain all necessary phase and amplitude information to allow the following SDR to demodulate any mode, although only single sideband is used in QDX.

3.8 Analog to Digital Converter

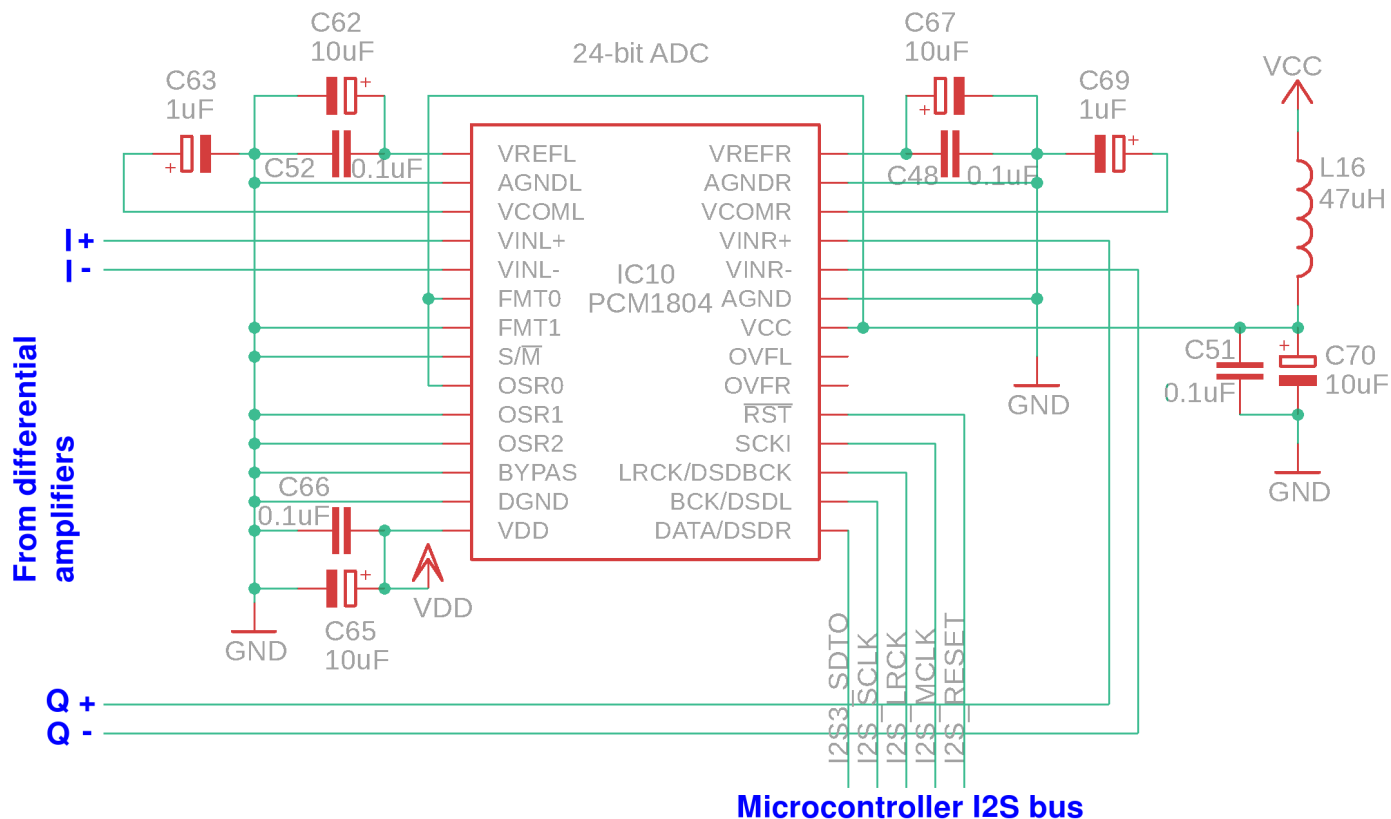

The PCM1804 Analog to Digital Converter (ADC) chip is a high performance stereo ADC chip with differential input. Its purpose is to convert the analog I and Q-channel signals to a digital representation to allow digital signal processing by the microcontroller, which implements a Software Defined Radio (SDR). The PCM1804 specifies a 112dB dynamic range and is used at 48 ksp/s (kilo samples per second).

All the Texas Instruments PCM1804 datasheet recommendations in regard to layout and supply decoupling with tantalum capacitors, are followed (they most probably had good reasons for writing all that stuff and even if they didn't, I'm not about to take risks here).

In this design, the PCM1804 chip acts as Master of the I2S interface and the STM32 I2S peripheral acts as Slave. The STM32 generates a 24.576 MHz clock signal (I2S_MCLK) which is 512 x the sample rate (i.e. 48,000 x 512 = 24,576,000). From this, the PCM1804 generates the bit clock (I2S_SCLK) at 3.072 MHz (64 bits per sample – two 32-bit fields, for Left and Right channels, of which 24-bits are populated). The processor also generates the Frame clock (LRCK) at 48 kHz. The I2S_RESET signal is supplied by the microcontroller and must be activated once at power-up to reset the ADC.

3.9 Embedded Software Defined Radio

This schematic fragment contains the whole microcontroller section around the STM32F401RB microcontroller.

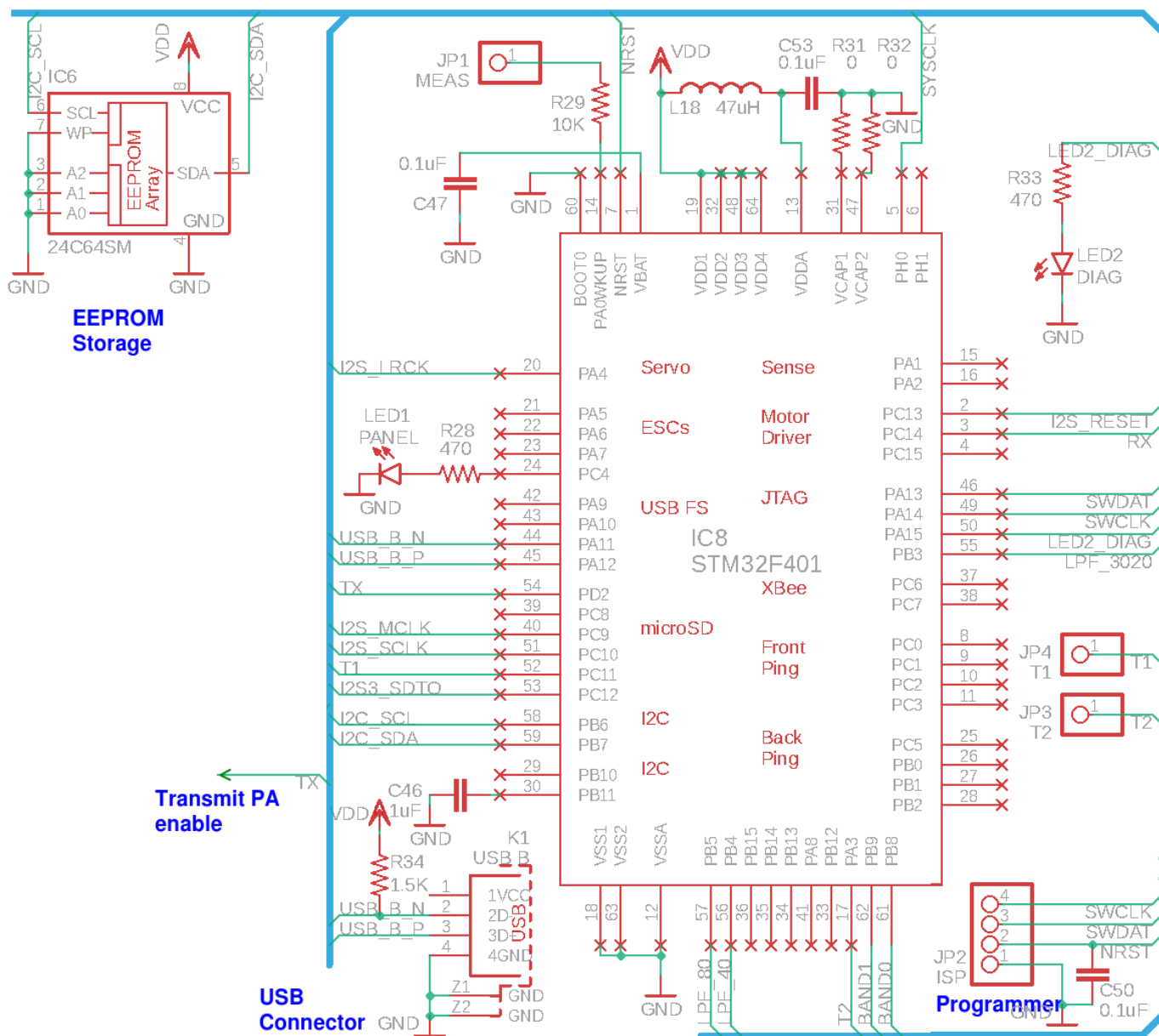

The microcontroller section of the schematic includes a 24C64 (8K x 8-bit) serial I2C EEPROM chip. Unlike the ATmega328 processors used in many other QRP Labs kits, the STM32 used here does not contain internal EEPROM so for storage of configuration parameters it is necessary to either use Flash storage or EEPROM. The problem with Flash storage is a limited 10,000 write-cycle specification which may be a little low. Therefore an external EEPROM chip is used.

The 4-pin programming header at the bottom right of the diagram is for factory use only to install the QFU bootloader on the QDX board. An onboard diagnostic LED is also used only for factory validation. LED1 is a front panel LED on the QDX which shows basic status information such as whether or not the unit is transmitting or receiving, or in bootloader (firmware update) mode. A transmit-enable output switches on the transmit driver to enable the RF power amplifier.

Other than that, all the magic goes on in the firmware, which is not open source.

The Software Defined Radio receiver (SDR) implements digitally a superhet receiver having a 12kHz Intermediate Frequency. The reason for doing this rather than processing directly at baseband as a direct conversion receiver, is that it eliminates any issues with power line hum – the harmonics of 50Hz or 60Hz (depending on your country) and other noise which exists around 0Hz.

The receive signal path processing contains the following stages implemented in the Digital Signal Processing (DSP):

- Retrieve a block of 32 24-bit audio I and Q samples from the ADC chip via the I2S bus
- “Mix” to 12 kHz Intermediate frequency, including a Low Pass Filter in the factor-of-four decimation process; the reason for the choice of 12 kHz as the intermediate frequency is that the mathematics becomes relatively easy, as it is exactly one quarter of the 48 kHz sample rate.
- A Hilbert Transform applies a 90-degree phase shift to one of the I and Q paths relative to the other; this is the equivalent of the analog all-pass phase shift network implemented using op-amps in the QCX CW transceiver.
- Sum or subtract the two paths to produce either the Upper or Lower sideband; QDX is capable of demodulating either sideband but digital operations normally use upper side band (USB) which is therefore the default operating mode.
- Apply a digital audio filter, which has a passband from 150Hz to 3.2kHz
- Interpolate back to 48 ksps audio
- Send the 48ksps audio samples to the PC over the USB Digital Audio link.

The performance of the receiver was tested using the internal signal generator to inject a signal into the QDX input at a defined offset; Argo software was used on the PC to determine the received signal amplitude.

Two different measurement runs were performed, with quite some elapsed time between them (17 months!). In both cases, there is no change to the firmware but the measurements were performed on different prototypes. There is no attempt at amplitude or phase compensation, which does not appear to be needed (the results are already excellent).

The vertical scale in dB has an arbitrary zero reference; the important point is the difference between the upper sideband (blue line), and the unwanted lower sideband (red line).

In the first example (shown below) dating from 06-Apr-2020, the worst case unwanted sideband suppression is at -64dB relative to the wanted sideband, which occurs at about 2,200Hz audio.

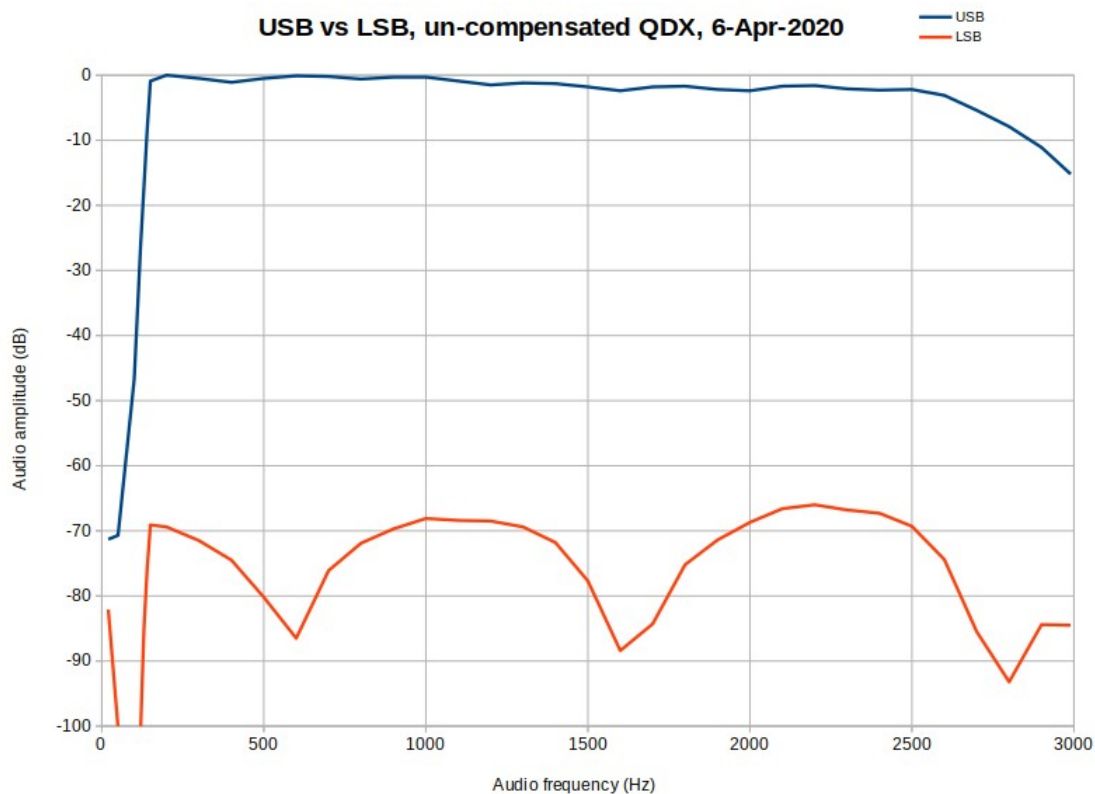

The second measurement (September 2021) shown below, shows a worst case unwanted sideband -60dB relative to the wanted sideband, again at about 2200Hz audio. The difference of 4dB between the two prototypes will have been due to component tolerances and build-style variations. In both cases, this is really good performance!

The second measurement was painstakingly made with much finer resolution (lower frequency steps) than the earlier measurement, which shows more clearly the behaviour of the Digital Signal Processing.

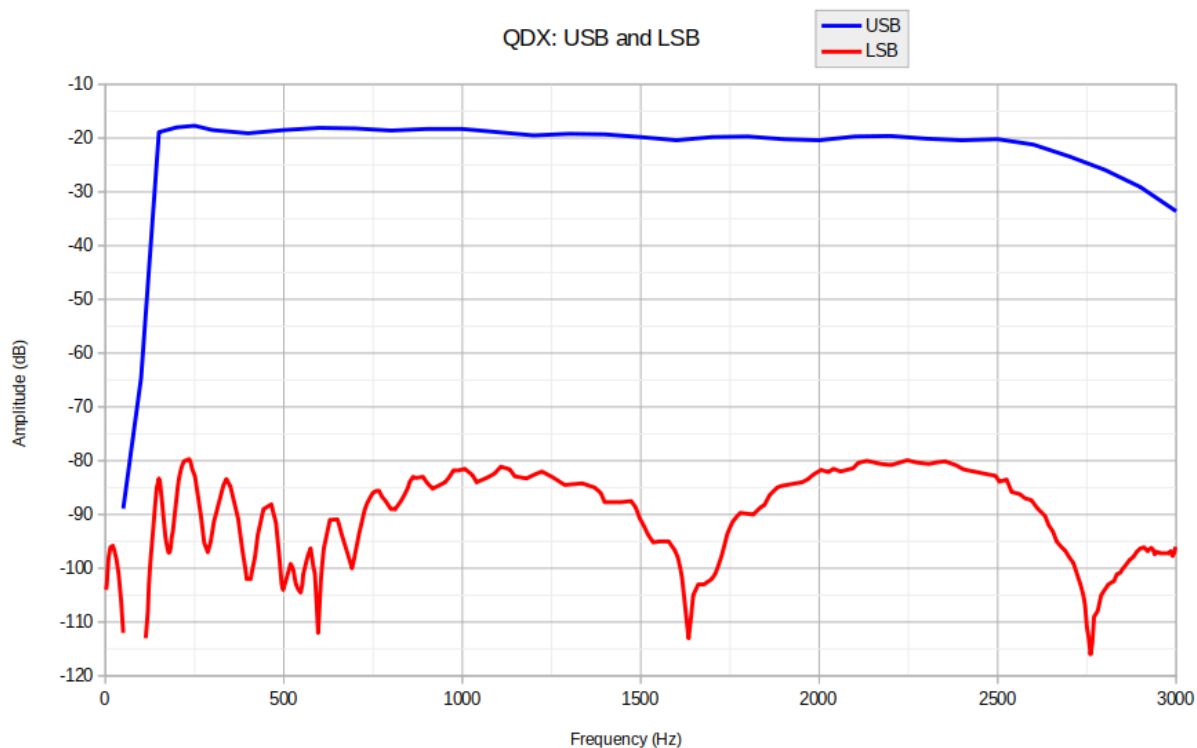

3.10 Embedded 24-bit 48ksps stereo USB Sound card

QDX has its own embedded 24-bit 48ksps stereo USB sound card! But there is not a real physical little piece of hardware strapped inside, like the PCB from a sound card dongle or something. Instead, the USB sound card is actually coded in firmware directly by the STM32 microcontroller, the same single microcontroller that is also doing everything else, in the design.

This is an extremely important design feature of QDX.

A radio transceiver having an audio input has a number of disadvantages:

- An audio cable is one more cable to have to plug in between your radio and your PC.
- There may be level mis-matches between the PC generating the audio signal, and the audio input of the radio. The PC will need to be carefully set up to set the volume such that the radio produces the expected RF proper power level, but does so without distortion (clipping, intermodulation distortion, splatter, however you want to refer to it). With the built-in QDX sound card, no level adjustment is necessary; set the volume to the max and rest assured that the QDX will never be overdriven (in fact it CANNOT be).
- Audio cables are a recipe for picking up noise, particularly in most of our lab environments where we power our equipment from grid power. You will often see 60 Hz (US) or 50 Hz (most of the world ex-US) harmonic lines on spectrum waterfalls. Ground loops can be hard to eliminate. With QDX and its built-in sound card, numeric audio sample data is transferred back and forth between the PC and QDX with zero loss, zero distortion, no hum or other noise. The quantization error due to sampling at 48ksps is minimal but is in any case matched by WSJT-X so a higher sample rate would not achieve an increase in performance. The benefit of direct digital numeric transfer between PC and QDX, without any conversion errors or noise, is enormous!

You can buy cheap USB dongles and connect them between your radio and your PC. But the dynamic range IS limited, and not just by the 6dB/bit theoretical relationship between bit depth and dynamic range, but also by the actual noise floor of the converter (the least significant bits are in other words, just noise).

In contrast, QDX uses a 24-bit stereo ADC chip with 112dB dynamic range specification. If you look at the specification of any expensive USB external sound card, and the price of getting anything like 112dB, you will appreciate the true significance of this.

All Digital Signal Processing in QDX is carried out at full floating point resolution, not limited to 16-bits as many SDR implementations do. In its communication with the PC this is rounded to 24-bits and transferred via the USB Digital Audio device class. WSJT-X only uses 16-bits so the PC sound system will automatically re-sample but still, the 24-bit USB sound is sent by QDX to support any future PC applications which use a higher resolution.

The result is a very high performance radio receiver, and equally, an excellent performance transmit side due to the zero-loss, zero-noise transfer of audio digitally from the WSJT-X synthesis straight to the QDX frequency analysis.

3.11 CAT control serial interface

QDX includes an emulated virtual COM (serial) port, all in the same STM32 processor that does everything else. The STM32 processor therefore actually includes THREE USB device classes:

1. Compound device class (a container for more than one other device classes)
2. Digital audio
3. Virtual COM (serial) port

The introduction of the compound device class makes QDX effectively, contain a virtual USB hub, to which is connected a Digital Audio USB device (the USB sound card) and a Virtual COM Serial Port. This allows a single USB cable to be used between QDX and the PC, the USB cable transfers both digital audio and serial data seamlessly between the two.

An important benefit of the CAT control interface is that it allows QDX to have a flexible tunable VFO and band switching, all without any actual physical controls. No physical controls are at all necessary because everything is done under the control of the WSJT-X software as CAT controller. Elimination of display and physical controls is not just a matter of lowering costs, it also makes the QDX extremely easy to use. Want to change bands? Simply click the drop-down in WSJT-X and QDX will automatically change bands. Want to use a different frequency (for example, change mode to WSPR, or perhaps even change software application to JS8Call)? The software application will automatically switch you to the correct frequency for the mode you select.

Another advantage of CAT control is that WSJT-X contains an option to effect the transmit/receive switch either by VOX (Voice activation, or in other words, the presence of audio) or by an actual CAT command to enable transmission. QDX also supports both methods, there is an entry in the configuration screen that allows VOX to be enabled or disabled. The default setting is “disabled”, which means a CAT command is necessary to switch from Receive to Transmit (and back).

The danger of VOX is that it is all too easy to accidentally have the QDX selected as the sound card for system noise outputs etc... then when a WhatsApp message from someone arrives, and the PC does its fancy “pling” sound, well that’ll be faithfully converted to a series of audio tones by QDX and transmitted accordingly. So disabling VOX and insisting on a proper CAT command to switch on to transmit, is the recommended modus operandi.

QDX also has a rich user interface via the Virtual COM port, by connecting a terminal emulator on a PC, to the virtual COM port. This is a whole blissful and enormous topic by itself, it allows interaction with all the built-in analysis tools in QDX as well as the configuration screen and features such as factory reset and firmware update.

3.12 Audio frequency analysis

Determination of the audio frequency arriving from the PC software (for example, WSJT-X) is key to the whole operation.

My first thought was a Fast Fourier Transform (FFT). However that quickly turns out to be a lot more difficult than it at first sounds. For the FT8 mode for example, the audio range is a 3kHz band. It isn’t so trivial to set up a FFT with 6.25Hz buckets, that wide, and would require a significant amount of processing power, such that I would need to use a more powerful (and expensive!) microcontroller than I’d really like. Furthermore WSJT-X modes are heavily optimized such that the period is the inverse of the tone spacing, so I might need to do TWO interleaved FFT analysis runs offset by half the tone spacing. Then there’s the problem of the frequency slide when

a tone changes. Furthermore, the QDX would have to know which mode was being transmitted, in order to configure the size (and hence speed) of the FFT buckets. I started to shudder and shake!

I soon realized that FFT would be the sledge hammer approach and there is a much simpler and faster way, which also offers higher accuracy.

The simple approach is to detect the zero crossings of the sinewave, and carefully time the period between zero crossings. Frequency is the reciprocal of Period, so once you have the period, a moment later you know the frequency too, and the problem is solved. It turned out to be very easy to implement this method, and the accuracy is rather impressive. Experimentally, a SINGLE CYCLE measurement of the frequency at 1500Hz audio frequency leads to frequency accuracy of around +/- 0.05 Hz. More than enough!

NOTE: 1500Hz is an unfair frequency to measure at, because each cycle fits into an exact number of audio samples; 32 audio samples at 48,000 cycles per second make up one 1500Hz audio cycle. This sets us up for an extremely low error cycle measurement. So to make things fair, I actually offset the frequency for the test, to around 1520 Hz, so that the cycle doesn't contain an exact number of samples.

In actual fact we don't really need to update the frequency of the Si5351A Synth 1500 times per second... that's excessive. QDX has configuration options that allow you to specify an averaging period, where a specified number of sound samples AND a specified number of audio cycles must both be exceeded, in order to terminate the audio cycle measurement. The default parameters are set for a minimum of one cycle, but a minimum of 480 samples. 480 samples is 0.01 seconds and since we never go as low as 100Hz, the dominant criteria is therefore a measurement of at least 0.01 seconds.

With this default configuration, we get 100 audio frequency measurements per second, and experimentally the frequency accuracy is better than +/- 0.002 Hz. Amazing.

As for the details of the analysis, study the following hypothetical sinewave:

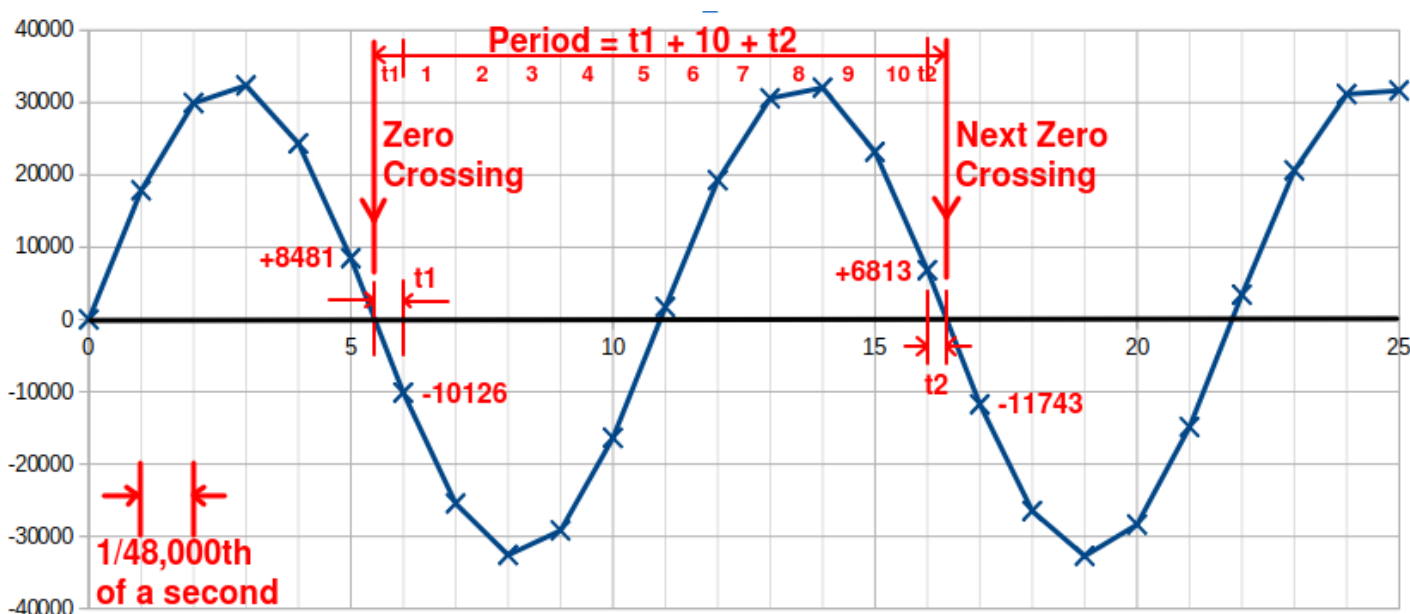

Remember that we have a built-in 24-bit 48kps stereo USB sound card. Accordingly we get 48,000 samples per second. In this example I am assuming WSJT-X is used; WSJT-X outputs 16-bit samples, so the extent of the sinewave data is from -32,768 to + 32,767. The sound samples are received from the PC via the USB cable and are absolutely FREE of any noise. It's a lossless and zero noise transfer between the WSJT-X software on the PC, and the QDX's firmware. The

sequence of sample numbers received are EXACTLY what the WSJT-X software generates in its audio software-DDS.

We also know that the sound samples arrive at exact equal intervals of one 48-thousandth of a second. This is effectively the time base of our period measurement. It is not necessary to run any kind of actual timer inside the microcontroller, because in this instance we already have the luxury of knowing we get exactly 48,000 samples per second from the PC.

In the graph, the sine wave is shown starting at sample 0, with amplitude zero. In general, except in special cases (such as 1500Hz as mentioned above), we won't have a subsequent zero crossing indicated by a sample with value zero. We will have a sample ABOVE zero, followed by a subsequent sample BELOW zero. It is easy to detect this situation in the firmware code, just by looking for two successive samples, the first one being positive and the second one negative.

In QDX the firmware detects positive-to-negative zero crossings but it could equally well be done on negative-to-positive zero crossings, it is of no importance. It would even be possible to measure the frequency of half-cycles, with half the accuracy. But this kind of extremism doesn't seem warranted, unless in future some kind of mode with very fast measurements is needed or perhaps, we need to quickly measure the frequency of very low frequency audio signals.

Once we have a positive value followed by a negative value, and we know that they are 1/48000th of a second apart, we now want to find the exact time of the zero-crossing itself. This is also quite easy with a straight-line (linear) approximation. For small angles (in radians) the well known approximation holds: $x = \sin(x)$.

The period of the measurement is then given by the fractional times calculated by interpolation, at the start and end of the sample, plus the number of complete sound samples that occur BETWEEN the zero crossings. This is a "number of samples", and we know that there are 48,000 samples per second, so now it is easy to calculate the time in actual seconds which is the Period of the audio cycle; then the frequency is 1/Period, and we're done.

An example

To give a worked example, consider again the above simulated sinewave samples (generated in a spreadsheet). For ease of viewing, there are not many samples per cycle, in other words, this is a much higher frequency than we will be dealing with in practice; but it serves to make the principles relatively easy to understand.

We see audio sample #5, which happens to have a value of +8481 (according to the spreadsheet). Now the next sample, audio sample #6, has a value of -10126. We want to know the fractional interval (in samples), that is at the start of this sinewave cycle. I have called this time t_1 in the diagram. Time t_1 (as counted in samples), is a fraction $10126 / (8481 + 10126)$. This is a straightforward linear interpolation between the values at sample #5 and sample #6. The result calculates to be 0.544203794 samples.

The next zero crossing occurs between sample #16 (value +6813) and sample #17 (value -11743). Now we want to know the time t_2 , which is the fraction of a sample that occurs between the time of sample #16 and the zero crossing. I hope that you can see that this fraction is given by, in this case, $6813 / (6813 + 11743) = 0.367158870$.

Next we can see that there are 10 complete sample periods in the cycle, between our two fractional pieces t_1 and t_2 . The complete period, measured in audio samples, is therefore $t_1 + 10 + t_2$, which is $0.544203794 + 10 + 0.367158870 = 10.911362664$.

By now, we have determined that our audio cycle being measured, has a period of 10.911362664 audio samples. We also know that there are 48,000 samples per second. Therefore the Period of the cycle in seconds, is $10.911362664 / 48000 = 0.00022732$.

The frequency of the audio tone is therefore $1 / 0.00022732 = 4399.08$ Hz.

All without anything too complex, no complicated DSP, Fast Fourier Transform, etc. Love it!

Error considerations

Now like any good scientist, we should consider the possible sources of error in this measurement technique and try to understand if it is good enough for our purposes.

Thinking about it, I could envisage three possible sources of error: audio amplitude error, timing error, and interpolation error (the straight line linear interpolation). Let's consider each of these in turn.

1) Audio amplitude error:

WSJT-X produces samples with 16-bit resolution. Other digimodes software may offer 24-bit resolution but I have not come across any popular modes or software that do this. Neither do I think there are any that provide BELOW 16-bit resolution. Since most users will use WJST-X, and other software anyway has similar facilities, I will use WSJT-X for the purposes of discussion.

A 16-bit resolution provides 65,536 amplitude values per sinewave cycle. That's a theoretical (and practically achieved, since we have the built-in USB soundcard and therefore a lossless, noiseless transfer mechanism) 96dB dynamic range in the information transfer between WSJT-X and QDX, a very accurate transfer indeed.

And yet – there are two scenarios where this can be dramatically reduced.

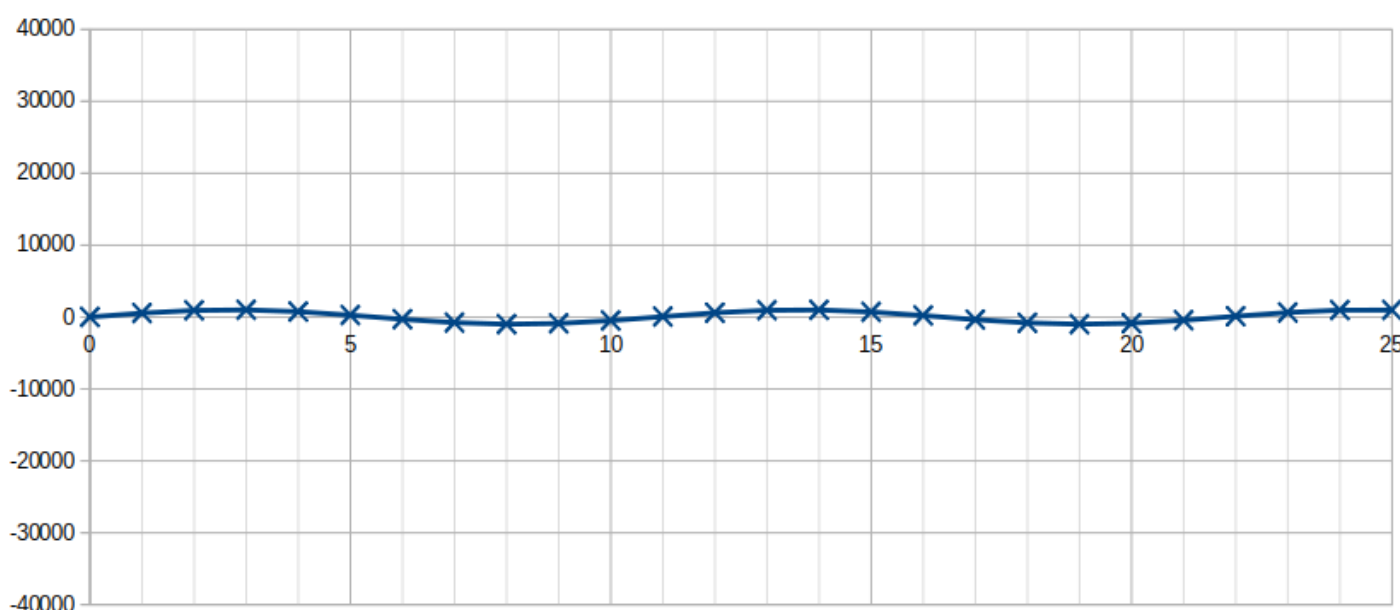

The first scenario is where the operator uses the output amplitude slider at the bottom right of the WSJT-X screen, to something less than maximum. On a more traditional digital modes station involving a SSB transceiver, this would be done in order to avoid over-driving the SSB transceiver's audio input, causing splatter. There is NO POINT to doing this on the QDX, since the QDX RF output simply cannot be overdriven. The QDX RF output simply **is**, it is the perfection of a

RF signal without any spurious residual carrier or attenuated unwanted sideband, without any audio harmonics due to over-driving and clipping.

But perhaps the operator wants to reduce the transmission output power, and uses the amplitude slider to do this? Again there is NO POINT, because QDX does not transmit at reduced output power. It's all or nothing. There is no in-between.

Therefore the operator should be advised for best accuracy, to leave the volume slider at the maximum value, as there is no point to any lower value choice anyway. I found I was able to move the slider to very low volumes anyway before the frequency measurement accuracy significantly deteriorated. So this is not a particularly serious concern. But the recommendation still remains, just leave the slider at maximum.

The second scenario where lower resolution sinewaves can be generated by WSJT-X, is during the key-down and key-up instants, where WSJT-X applies (I believe), a raised cosine amplitude envelope to the beginning and end of the transmission. For the sake of design simplicity and because it is much less critical in digital FSK modes, than on/off keyed modes such as CW, amplitude envelope shaping has been omitted from the QDX design.

So there is no point to WSJT-X sending reduced amplitude sine waves at the beginning and end of the transmission key-down, since QDX cannot implement that anyway. Of course, WSJT-X does not know this, and there is no way to turn it off, so it will happen anyway. We can't "advise" WSJT-X software in the same way as we could advise the operator to leave the slider at maximum setting, in the previous discussed scenario.

At very low amplitudes, there would be a much more significant quantization error due to the limited amplitude resolution, that has the potential to increase the frequency estimation error substantially at very low amplitudes such as when the raised cosine envelope shape starts. This could cause a frequency estimation with a significant amount of error, and the Si5351A Synthesizer to start producing RF at an incorrect frequency.

To avoid this possibility completely, the QDX has a configuration ("Rise threshold") which allows it to ignore any audio cycles until a certain percentage of full amplitude has been reached. This can be set to a high percentage value such as 80 or 90%. This will ensure that there is no initial frequency value with a high error. Transmission will not occur until the 80% threshold (for example) is reached.

As a side-benefit, this will also FORCE the operator to keep the volume slider at the maximum value, or there will be no RF output! The "advice" will become binding.

The threshold should not be set to a very high value such as 99% because at high frequencies, where the cycle is made up of a smaller number of sample values, there may be no sample value near the actual peak of the sinewave, and so it may take several cycles for perchance, a value to exceed the threshold.

There is a similar "Fall threshold" setting to switch off the transmission at a defined amplitude threshold, before the raised cosine trailing edge of the amplitude envelope generated by WSJT-X takes the amplitude to a very small number and causes a potentially inaccurate frequency measurement.

"Rise threshold" has a default value of 80% and "Fall threshold" has a default value of 60%; it is unlikely the operator would ever want or need to change these from the default values. The default values are not critical but they should be neither very small, nor very large; and furthermore the falling edge threshold should be somewhat smaller than the rising edge threshold, otherwise key-up will be effected prematurely.

When the operator uses the maximum volume setting, and thresholds are implemented to avoid the possibility of high calculation error at very low amplitudes which could occur during the raised cosine leading and trailing edges, the effects of amplitude error are practically speaking, of no consequence.

2) Timing error:

USB audio devices transfer data to and from their PC host at an agreed rate. In the case of QDX, it appears to the PC as a 48ksps (48,000 samples per second) 24-bit stereo USB sound card. However, in common with all such USB audio systems, there is no facility for synchronization between the PC USB host, and the USB device. In other words, there is no 48kHz clock signal between the two. In the Full Speed USB protocol, the host and device communicate via data packets sent 1000 times every second.

Now it can get all rather complicated... because the host may send data to the device at not exactly 48kHz, and the device may send data to the host at not exactly 48kHz either. There are specifications in the USB standards that define the worst allowable error percentage. Now both ends of the connection have to try to deal with the fact that there is ALWAYS going to be a difference between them. Even if both 48kHz crystals derive their sample rates from a quartz crystal reference, the crystals will not be at exactly the same frequency.

In the case of QDX, there is a 25MHz TCXO that operates as the CPU clock input. All signals are derived from this clock, including the 72.something CPU clock, and the 48MHz USB peripheral clock (well, CLOSE enough to 48MHz), and the I2S peripheral master clock which is at 512 times the sample rate (each sample has 512 clocks); or $48\text{kHz} \times 512 = 24.576\text{ MHz}$.

This 24.576 MHz signal is derived internally in the QDX, by a PLL multiplication factor of 117, then division factors of 17 and 7. So $25 * 117 / (7 * 17) = 24.579832\text{ MHz}$. Dividing by 512 gives an audio sample rate of 48007.5 samples per second! As well as this synthesis accuracy limitation there's also the smaller imprecision in the 25MHz TCXO oscillation value.

Luckily, this small 7.5 samples per second difference is well within the allowable percentage error in the USB sound device specification. On the PC side, the built-in USB driver has to deal with this difference, in addition to the fact that its own master clock will also not be truly at precisely 48kHz; it does so, I believe, not by digitally re-sampling to what it thinks is exactly 48ksps, but by some kind of software phase lock mechanism.

On the incoming data from the PC over the USB interface, we're also not going to be getting data samples at exactly what WE believe is 48ksps (our belief also being slightly inaccurate, itself). So what do we do... certainly I'm not going to dabble in software PLL clock recovery; an option could be do occasionally drop a sample if there are too many, or to duplicate a sample from time to time when there are, in my judgement, too few.

But in the end, after all this waffle, none of it is necessary. It is perfectly acceptable to do NOTHING about the lack of synchronization, just nothing at all! It is fine to pretend that we get exactly 48,000 samples per second, and analyze them all perfectly as though everything was exact. If there is any sample rate error, it will simply produce in the calculation result, a proportionate error in calculated frequency. Even a 1Hz error, if it happened (and frankly, I have never seen even a 0.01Hz error), would be of no consequence to operation of the transceiver, alongside much more significant errors such as the precision of the RF synthesis.

In the end therefore, the conclusion is that timing errors are of no consequence.

3) Interpolation error

Remember the approximation we have used for the zero-crossing interpolation that determines the exact moment of the zero-crossing event? Mathematically, the approximation is that for small values of x , then $\sin(x)$ equals x . Put another, less mathematical way, we can draw a straight line between the two points we want to interpolate, which makes the calculation easy.

What can cause this to generate error? Well, when we are no longer dealing with “small values of x ”. Practically speaking in our case, this occurs when there are a lower number of samples per audio cycle.

Consider an extreme example, for the sake of demonstration – here is a an 8.4kHz sinewave (much higher than we will ever be dealing with):

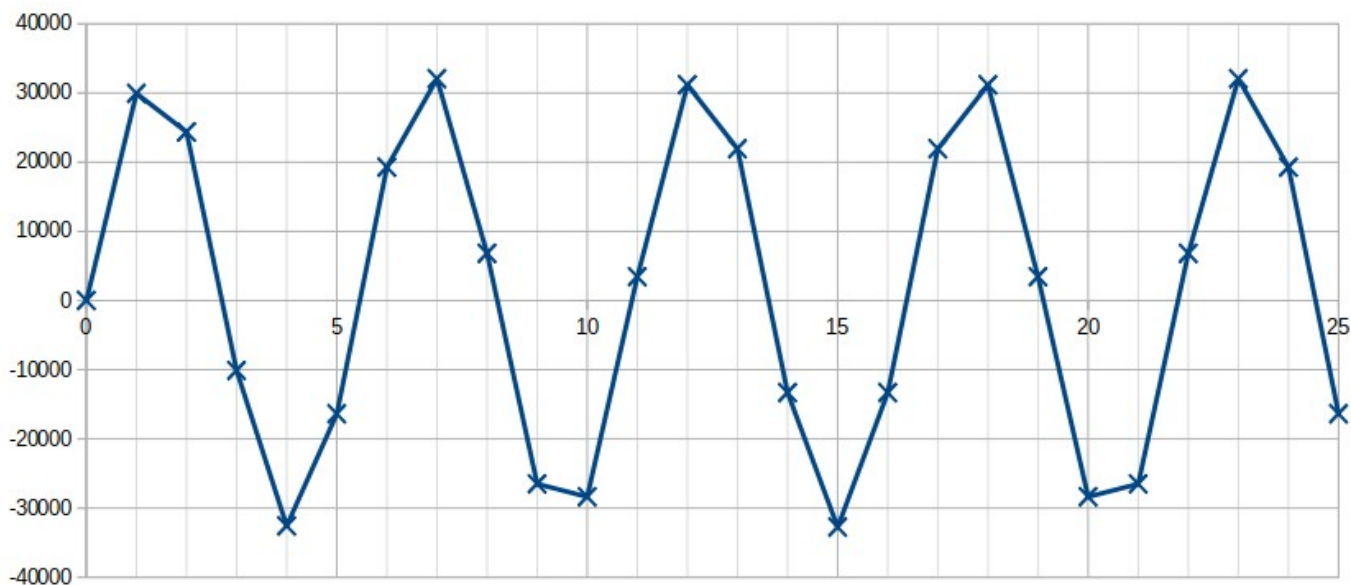

You can see that the sample points, indicated by the X's, are quite far apart. The zero-crossing time, or the time between the two samples adjacent to the zero-crossing, is a relatively large fraction of the cycle period. Our “ x ” is therefore not so small as it was before. The straight lines that previously didn't look at all bad, now look a lot less like the sinewaves that are being approximated.

Now consider this sinewave which happens to be about 1.27 kHz:

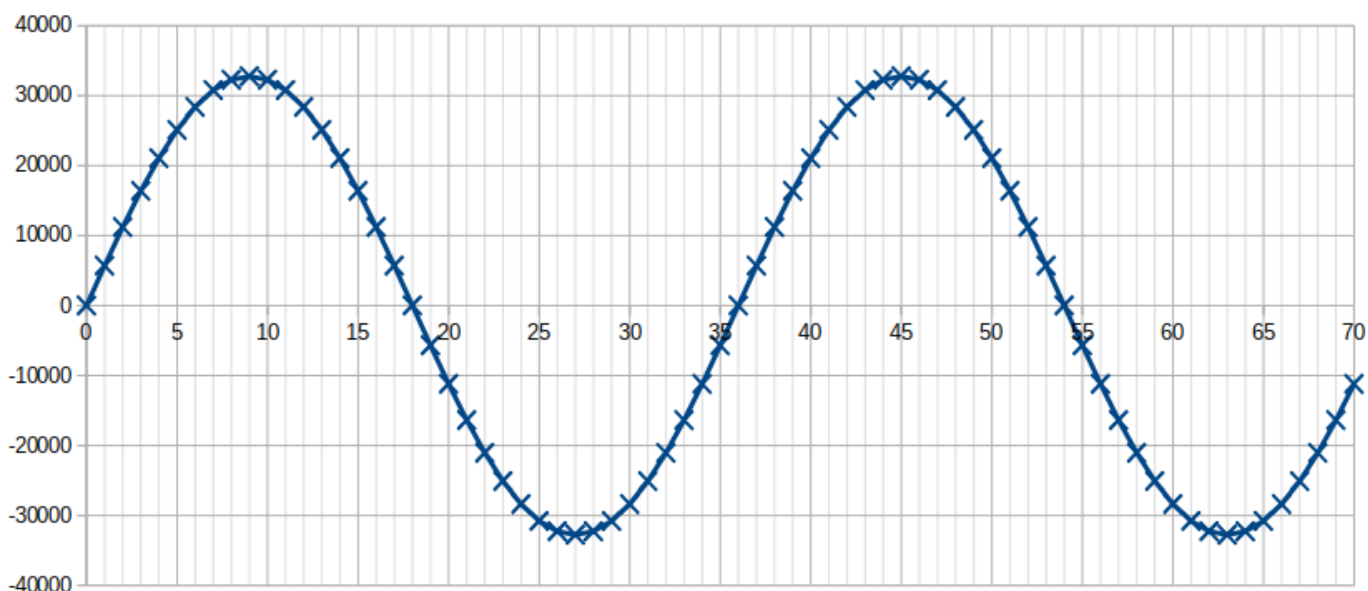

Obviously it LOOKS a lot better but we can also see that using straight lines at the zero crossing, will be a very much better approximation to the sinewave, than the high frequency case.

We can therefore say that when the sample rate is fixed at 48ksps, a low frequency audio sinewave is a lot more accurately interpolated, than a higher frequency audio sinewave. In other words, the errors get bigger, and quickly so, as we increase the audio frequency. This can also easily be seen experimentally by generating a signal in WSJT-X and then observing the measured frequencies (this can be done using QDX's own built-in tools, as described elsewhere in this manual).

The error in frequency measurement is also reduced by measuring over more than one cycle. Since we are adding a fraction of a sample at the beginning, and a fractional of a sample at the end of each cycle, and counting the number of samples in between – any error on the fractional estimations (due to linear interpolation error) will be reduced by counting multiple samples. For example, if we measure for 2 cycles, the error will be halved. If we measure for 10, the error will be reduced by a factor of 10.

As mentioned earlier, it is quite unnecessary to count the frequency so often as a SINGLE cycle. If we are measuring say, an audio signal of around 3kHz – do we really need to measure it 3000 times per second? Not practically speaking, no.

So the QDX has a configuration built in, which specifies a number of cycles that must be measured, and a number of samples that must be measured. BOTH of these parameters must be satisfied, before the measurement activity completes. The default values are 1 cycle, and 480 samples. 480 samples is a time duration of 0.01 seconds. In this configuration, a very low frequency signal, below 100Hz (0.01 seconds period) would be measured properly. And at any higher frequencies than 100Hz, the minimum samples criteria will dominate, and ensure that the averaging period is automatically increased for higher frequencies! For example at 3kHz, 480 samples will contain 15 cycles, so the error in the fractional period estimation due to interpolation inaccuracy, will be reduced by a factor of 15. In this way, high frequencies do more averaging than low frequencies; we get 100 frequency measurements per second.

Again these configuration parameters are not particularly critical, and again, the default values will suffice for all imaginable purposes and most likely the QDX operator will never want or need to change these, other than perhaps for his own curiosity of investigation.

Sinewave interpolation

As an aside – for interest only – I did investigate the possibility of more advanced interpolation methods than linear (straight line). I spent some enjoyable time experimenting with a method which measures the amplitude of the sinewave (looking at the incoming samples) and then fits the two samples either side of the zero crossing to an actual sinewave rather than a straight line.

It did provide some improvement, some observable reduction in error. However, the error reduction was not as great as I had expected, and I suspect this is due to limitations in the floating point accuracy of the arc-sin implementation, perhaps (speculation) a limitation to the number of terms of a polynomial expansion? Furthermore, although the STM32 processor used has a floating point unit, the calculations were still too slow at the 72MHz CPU clock speed used. In experimental measurements the calculations were too slow to be able to perform single cycle frequency estimation at the upper end of the frequency range, which is exactly where we most need the improved accuracy; multiple cycles were therefore necessary and it was found that the improvement in accuracy of averaging simple straight line interpolation over several cycles, was more than the improvement in accuracy of the slow sinewave interpolation!

Furthermore other inaccuracies could creep in, such as the estimation of the maximum amplitude; or we'd have to assume the maximum amplitude sinewave, which would work less well on the rising and falling keying edges.

I toyed briefly (very) with the idea of trying to implement a three (or more) point sinewave fit, but dismissed it as it would involve even more calculation and be even slower. Polynomial fits were another possibility considered.

But frankly – in the end – the simple linear interpolation is very reliable at the frequency range of interest, and is already SO good, that the idea of trying to pursue more advanced approaches, seemed, particularly after a day's worth of investigation, to constitute an unnecessarily frivolous indulgence in mathematical decadence.

Errors conclusion

The frequency estimation by cycle timing method employed in QDX is exceptionally accurate, far more precise than needed for any digi modes likely to be employed on HF bands during QDX operation (I cannot imagine any exceptions). There are a few boundary cases where accuracy could conceivably be impaired, and though this is actually still unlikely to be of any practical significance, configuration parameters are provided to mitigate and control the errors, with suitable default values that will be excellent for all conceivable use cases.

As a final word on audio frequency estimation, I want to also mention that WSJT-X is said to transition evenly between two frequency symbol tones, by implementing a raised cosine falling envelope shaping on the finishing tone, at the same time as a raised cosine envelope shape on the newly starting tone. As discussed previously, QDX just doesn't do envelope shaping. However, I believe that to all intents and purposes, that this fancy raised cosine tone envelope shaping is equivalent to a gentle "frequency slide" between the old and new tone frequencies. Perhaps it is even exactly mathematically equivalent, I don't know.

At any rate – for any mode WSJT-X generates, QDX will continuously measure the frequency and update the transmitter output frequency accordingly; at 100 updates per second (the default configuration) this is plenty sufficient to achieve smooth transitions between tones; additionally the frequency synthesis method used in the Si5351A itself causes a "slide" between frequencies not a sudden discontinuous transition, because the PLL takes a finite time to settle on the new value.

QDX contains its own test and analysis tools built-in; elsewhere in this manual is a description of how you can observe these frequency transmissions yourself, using the built-in tools.

Si5351A fine control

Historically QRP Labs products have set up the Si5351A with an integer frequency, except for the Ultimate3S QRSS/WSPR transmitter which has an algorithm during WSPR operation to optimize the frequency steps for very accurate 1.46 Hz tone spacing.

The problem with QDX is that the QDX must faithfully transmit any frequency given to it. The tone spacing may be very fine, or it may be coarse. QDX does not know. QDX knows nothing of the transmission mode. All QDX does is receive audio tones from a PC and effectively modulate them to RF. The tones may be 1.46 Hz spaced in the case of WSPR, or 6.25 Hz in the case of FT8, or many other possibilities. Therefore a fixed algorithm for WSPR such as Ultimate3S has, or an integer frequency configuration such as used in the QCX CW transceiver, will not be optimum here.

As an example, suppose we want an output frequency of 14,097,002.123 Hz and the firmware has to decide the parameters to configure the Si5351A chip. So let's say we chose a MS Synth divider of 62 (abiding obediently by the even integer MS Synth divider rule). Now that means the internal VCO must operate at 870,014,131.626 Hz. The multiplication factor from 25 MHz is therefore $870,014,131.626 / 25,000,000 = 34.960565265039996$. Now that has to be represented as $a + b / c$ where all are integers, b is in the range 0 to 1,048,575 and c is in the range 1 to 1,048,575 (b and c are 20-bit numbers – so the max value is $2^{20} - 1$).

The question therefore is the choice of b and c to get the fraction 0.960565265039996. Conventionally one may simply set c to 1,048,575 and set b to $0.960565265039996 \times 1,048,575 = 1,007,224$. Now we can calculate the output frequency:

$$25,000,000 \times (34 + 1,007,224 / 1,048,575) / 62 = 14,097,001.845 \text{ Hz}$$

The error in the output frequency is $14,097,002.123 - 14,097,001.845 = 0.228$ Hz. It's rather larger than we might like; remember also that the error will be different every time and could be better or worse than this.

Well it turns out we took the cowardly way out by choosing the denominator (c) to be $2^{20} - 1$ (1,048,575) and that there are better choices which will bring the ratio b / c very much closer to the desired fraction 0.960565265039996. In fact the choice $b = 416,333$ and $c = 433,425$ works very well... look, now the output frequency is:

$$25,000,000 \times (34 + 416,333 / 433,425) / 62 = 14,097,002.123 \text{ Hz}$$

The error, to three decimal places, is now 0.000. Bingo!

However the question is STILL, how to choose b and c to get this magical and wonderful result. The answer is "best rational approximation" which delves into an area of mathematics called "continuing fractions". Rather than spoil (and lengthen) this manual with my own garbled interpretation, allow me to just refer you to Google and Wikipedia https://en.wikipedia.org/wiki/Continued_fraction .

The implementation in QDX is a simple and fast iterative algorithm based on the information found here, which rapidly converges on values for b and c which provide a very optimal ratio.

3.13 Class-D Push-pull Power amplifier

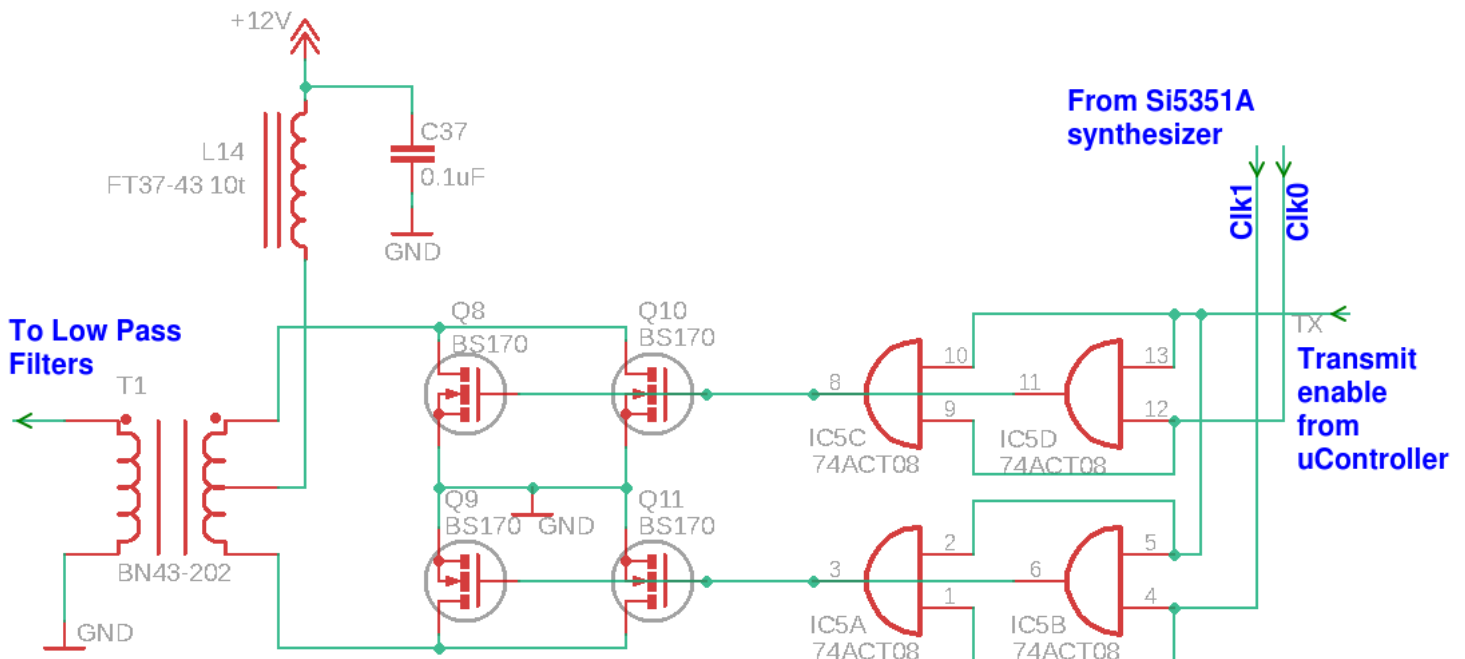

An interesting power amplifier circuit was designed specially for this transceiver. There are four BS170 transistors. Two are connected in parallel for the “push” side, and two connected in parallel for the “pull” side. Each side is driven by two AND gates of a 74ACT08 quad AND-gate IC, in parallel to ensure strong and fast drive.

The AND gate drivers are clocked from two outputs of the Si5351A Synthesizer which are arranged to have 180-degree phase shift. This provides the necessary phasing for the “push” and “pull” sides of the amplifier, without requiring an input transformer. All the 74AC08 AND gates are enabled by a “transmit” or in other words, a “key down” signal from the microcontroller; only when this signal is high, are the oscillator signals passed on to the MOSFET “gate” connections – this is the operation of the logical AND function.

The outputs of the “Push” and “Pull” sides are combined by transformer T1.

This power amplifier design provides a number of useful features:

- Class-D operation is efficient compared to Class C, or even worse, Class A/B linear which as discussed previously, is overkill for this application. Class-D is not as efficient as Class-E (as used in the QCX CW transceiver), but it better suited to a multi-band transceiver, since a Class-E amplifier has a resonant load circuit and this must be switched by band.
- Push-pull operation provides 5 W output power at a lower voltage than would be needed in a single-ended amplifier (9 V supply produces about 5 W output).
- Push-pull operation cancels even harmonics which are therefore at a very low level (due only to imperfect cancellation due to slight differences in transistor characteristics). Importantly the 2nd harmonic level is very low, which greatly simplifies the demands on the Low Pass Filters that will subsequently clean up the signal after the amplifier.
- Push-pull operation allows us to use four BS170 transistors to spread the load, but they are only connected in pairs so the driver only has to drive two paralleled gate capacitances not four.

- Using an antiphase drive (the precise 180-degree out of phase signals from the Si5351A) eliminates the need for an input transformer that is normally required in push-pull power amplifiers.
- All components are low cost and easy to replace in the unlikely event of failure.

As an example spectrum analyzer output, consider the following trace showing an 80m QDX. For this measurement, a 50-ohm dummy load was connected directly at the output of transformer T1, with no Low Pass Filtering.

The second harmonic is seen, about -70 dBc (70 dB below the fundamental) due to the cancellation effect of the Push-Pull amplifier. The subsequent even harmonics are even lower amplitude. Only the odd harmonics are problematic and require filtering.



3.14 Switched output Low Pass Filters

Every radio transmitter always requires low pass filters at its output to attenuate any out of band spurious emissions to sufficient level to comply with regulatory requirements (for example FCC in United States).

In QDX the Low Pass Filters are carefully optimized to provide excellent performance with low parts count. This can be achieved because the Class-D push-pull power amplifier design produces a very low level of even harmonics.

It is very important to reiterate that Low Pass Filter and Power Amplifier design must be considered carefully, at an overall SYSTEM LEVEL. In fact this applies to the entire transceiver design, but nowhere more importantly than the transmitter output stages, where the performance is critical to your regulatory compliance. The requirements on Low Pass Filtering are determined by the level of spurious emissions produced by the final Power Amplifier as well as levels in earlier stages feeding into the power amplifier. One cannot simply transplant a circuit block from one transceiver design to another, and expect the performance to be satisfactory. System level design is critical.

In QDX there are three Low Pass Filters. Each is made up of a 5-element filter, with a 6th element as resonant trap at the 3rd harmonic. The three filters are:

- 80m
- 40m
- 30/20m

The intrinsically low levels of 2nd harmonic is what lets us share the third filter between 30m and 20m.

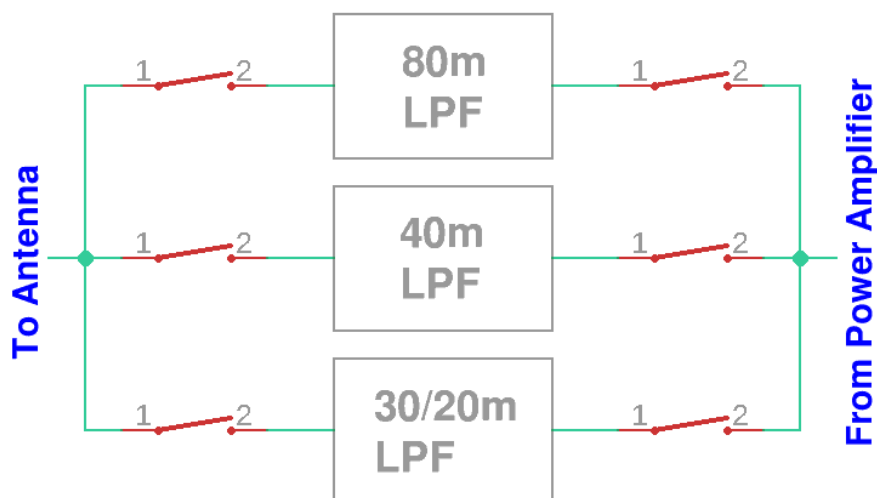

There is a PIN diode switch either side of each Low Pass Filter. So at any one moment, one pair of switches is activated, to switch the appropriate Low Pass Filter into the circuit.

The discussion of this block of the circuit divides naturally into a two parts: the LPF design, and the PIN diode switches design.

Low Pass Filters

The Low Pass Filter design was done using the Elsie program by Tonne Software. It is freeware and can be downloaded from here: <http://tonnesoftware.com/elsie.html>

80m:

For 80m this is the final schematic, having a resonant trap at the third harmonic:

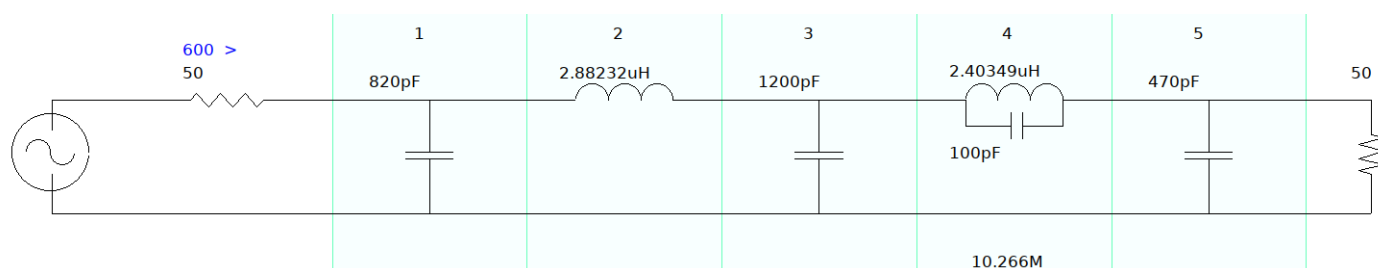

The simulation shows:

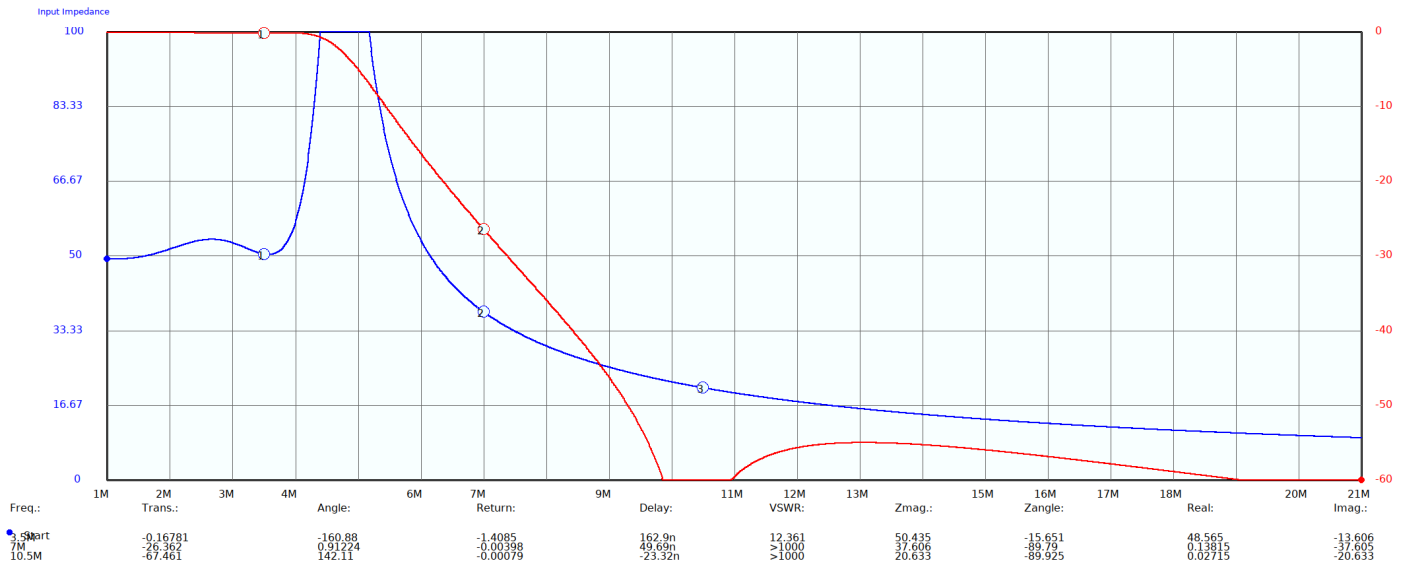

Fundamental: 3.5 MHz -0.17 dB
 Second harmonic: 7.0 MHz -26.4 dB
 Third harmonic: 10.5 MHz -67.5 dB

40m:

For 40m this is the final schematic, having a resonant trap at the third harmonic:

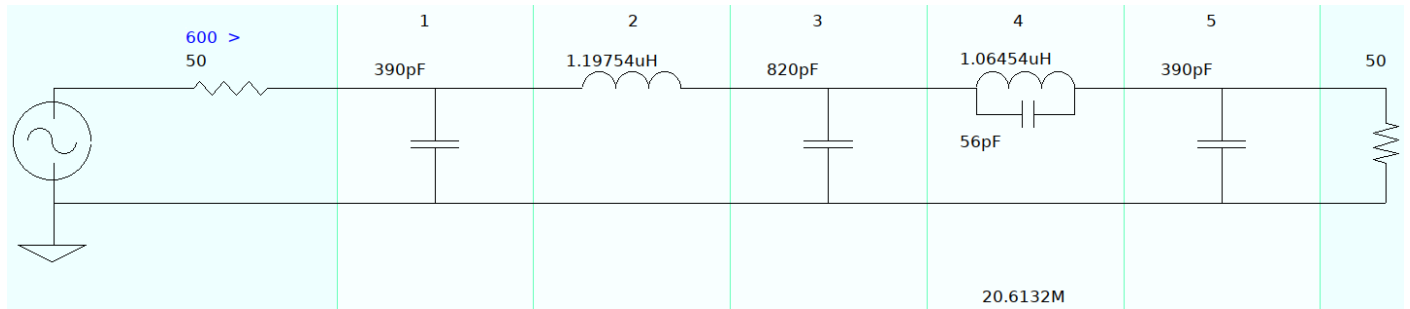

The simulation shows:

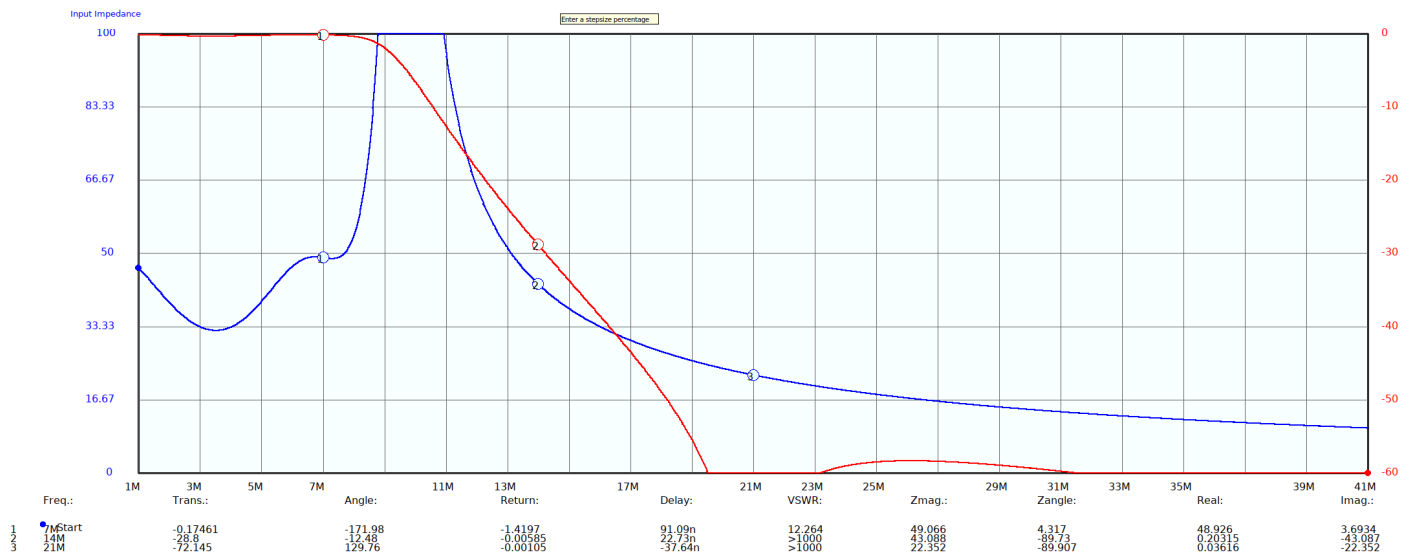

Fundamental: 7 MHz -0.17 dB
 Second harmonic: 14 MHz -28.8 dB
 Third harmonic: 21 MHz -72.1 dB

30/20m:

For 30/20m this is the final schematic, having a resonant trap at the 20m second harmonic, 28MHz. This is a departure from the 80 and 40m designs, which have the trap at the third harmonic. The reason for this is that the 20m second harmonic is close to the 30m third harmonic. This was found to represent an optimal compromise between 30m and 20m performance.

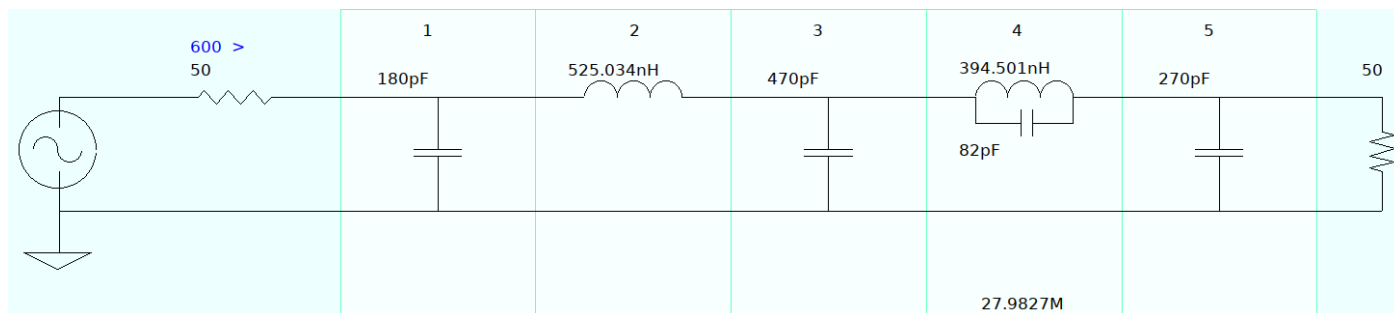

The simulation shows:

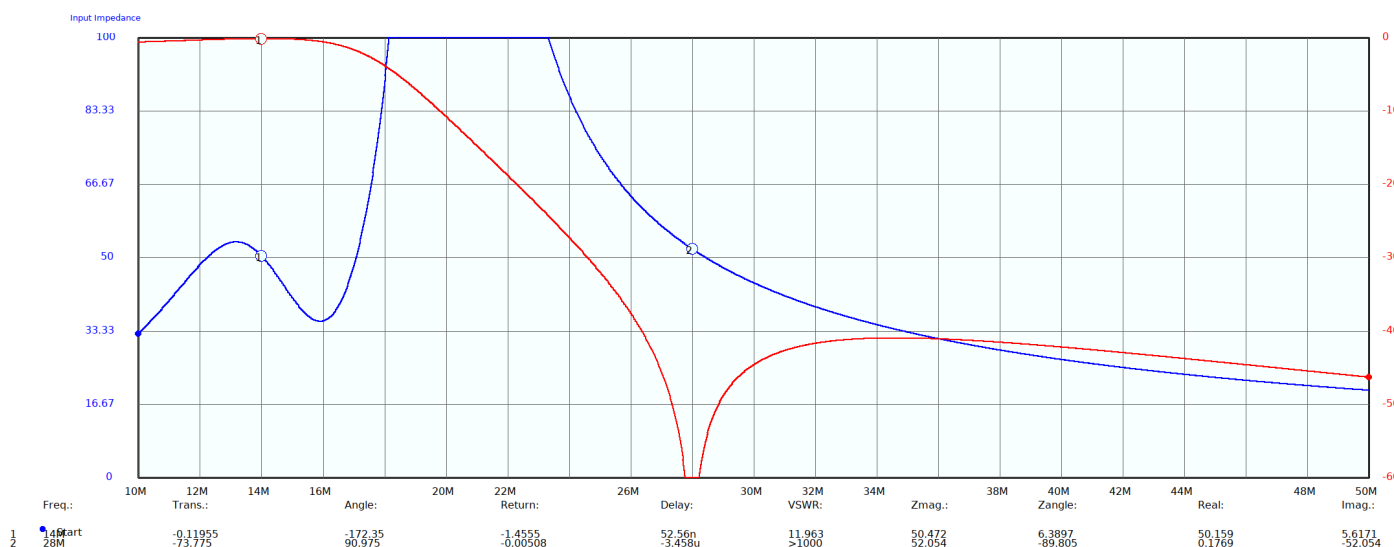

20m:

Fundamental: 14 MHz -0.12 dB
 Second harmonic: 28 MHz -73.8 dB

On 30m, while the second harmonic (20.2 MHz) attenuation is only about 12dB, the even harmonics are in any case at a very low level; the more important harmonic is the 3rd harmonic and for 30.3 MHz the attenuation is about -45 dB which is very satisfactory.

Low Pass Filter switching

The schematic of the Low Pass Filters and switching arrangements is shown below.

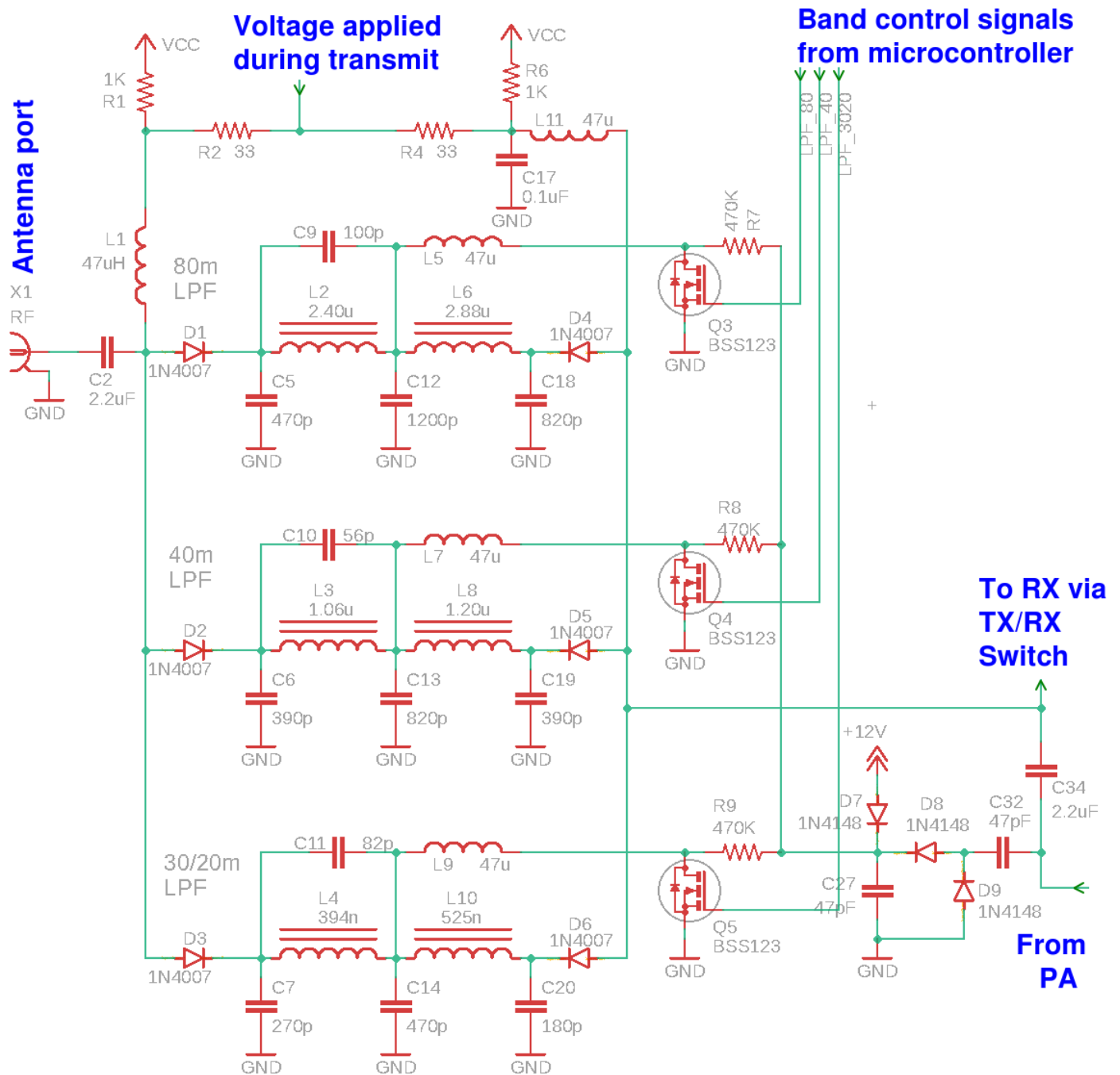

Very often relays are used for Low Pass Filter switching. However relays have several disadvantages:

- Bulky
- Noisy
- Expensive
- Potentially unreliable (mechanical moving parts)
- Poor isolation at RF, can be important in some applications (unless expensive relays used)

Cost and bulk are of critical importance here. A better solution comes in the form of diode switching. Not just any old diode, PIN diodes. This is a fascinating topic and I did a great deal of research and experiment to perfect the circuits used in the 50W PA kit <http://qrp-labs.com/50wpa> and many of those ideas are carried over to the QDX design.

Ordinary diodes cannot be used for switching because they could act as Rectifiers, switching on and off in time with the RF cycle. A PIN diode, however, is different. It is a diode with a wide undoped “intrinsic semiconductor” region between the usual P-type and N-type doped semiconductor layers of a regular diode (Wikipedia image).



The important point is that this undoped “intrinsic layer” acts like a storage reservoir. When incoming forward-biased current arrives, this “intrinsic layer” fills up with electrons. When the diode is reverse biased, it takes time for all these electrons to empty out of the intrinsic layer. At high enough frequencies, the time available is too short! So the diode never “turns off”. It remains conducting through the whole RF cycle.

PIN diodes behave like variable resistances. Their resistance is determined by the amount of DC forward bias current. They are near-perfect variable resistors which add very little distortion to the signal. In our case, we don’t care about variable resistors, all we want is either a very low resistance (On), or a very high resistance (Off).

A problem is that PIN diodes tend to be expensive, harder to find items. However, a solution comes along, the 1N4007 rectifier diode! This is the big brother of the 1N400x series of rectifier diodes, and has a reverse voltage rating of 1,000 V. By good fortune, its internal construction in order to achieve this very high PIV rating, is very similar to a “real” PIN diode. Hence the 1N4007 is often referred to as the “Poor man’s PIN diode”!



No doubt the 1N4007’s characteristics are not repeatable enough, or its resistance not linearly controllable enough, or some such other imperfection, that it is not suitable for all applications. But in our application where all we need is an On/Off switch at HF, a 1N4007 costing mere cents functions just as well as a “real” PIN diode costing 50x the price!

1N4007 functions well enough as a PIN diode switch across the whole of HF to 10m band, and even down to 500kHz.

What about dynamic range and third order intercept point IP3? A properly handled 1N4007 should not impact the dynamic range or IP3. An excellent set of measurements by Claudio IN3OTD see https://www.qsl.net/in3otd/electronics/PIN_diodes/PIN_diodes.html and https://www.qsl.net/in3otd/electronics/PIN_diodes/1N4007.html confirms the excellent characteristics of the 1N4007, which at HF in this switching application are similar to other PIN diodes. Other experimenters have determined similar results. Broad conclusions are that a properly biased 1N4007 at HF (1.8 MHz-30 MHz) has the following characteristics:

- “On” insertion loss less than 0.1 dB for 10 mA forward bias current
- “Off” isolation at least 30 dB (at worst case, 30 MHz frequency)
- IP3 > +50 dBm

Therefore the use of 1N4007 PIN diode switches should result in very little loss of transmitter output power, very little loss of sensitivity on receive, and will not degrade the excellent IP3 (and dynamic range) characteristics of the QDX transceiver with its high performance double balanced Quadrature Sampling Detector front end.

Remember that for a diode to be ON, it should be passing at least 10 mA current. In QDX, the forward current is set at 38 mA during transmit, this is determined by the bias circuit around Q1 and Q2 which will be discussed in a moment. Why so high, you may wonder? The reason for 38 mA is that the diode, if biased at lower forward currents, increases the level of even order harmonics due to its own distortion. 38 mA switches it ON so well that the distortion level is very low.

Remember also that capacitors block DC, but allow the passage of RF; whereas inductors block RF, but allow the passage of a bias current (Direct Current, DC).

In the ON state, the microcontroller I/O pin controlling the Low Pass Filter is set to high impedance, resistor R12 (10K) to +5V then pulls the potential at the gate of MOSFET Q5 to +5V, switching ON the Q5 MOSFET. The bias circuit can now drive 38 mA through each of L1 and L11, through the respective diodes D3 and D6, through L4 and L10 respectively, the sum of the currents (76 mA) through L9 and through the Q5 transistor to ground. These flows are indicated by the pink arrows on the diagram. The various capacitors block DC, only permitting the bias current to flow through the components indicated by the pink arrows.

Now that a sufficient forward bias current flows in D3 and D6, RF will see a low resistance all the way from the PA, through C34 and D6 to the Low Pass Filter; and on the other side of the filter, RF will pass easily through D3 and C2 right to the antenna. L1 and L11 block RF from escaping into the bias current circuits.

In the ON state, we think about current (forward bias current). In the OFF state, we must think about voltage (reverse bias voltage). Here's the same schematic, labeled for the OFF state.

Switch OFF state

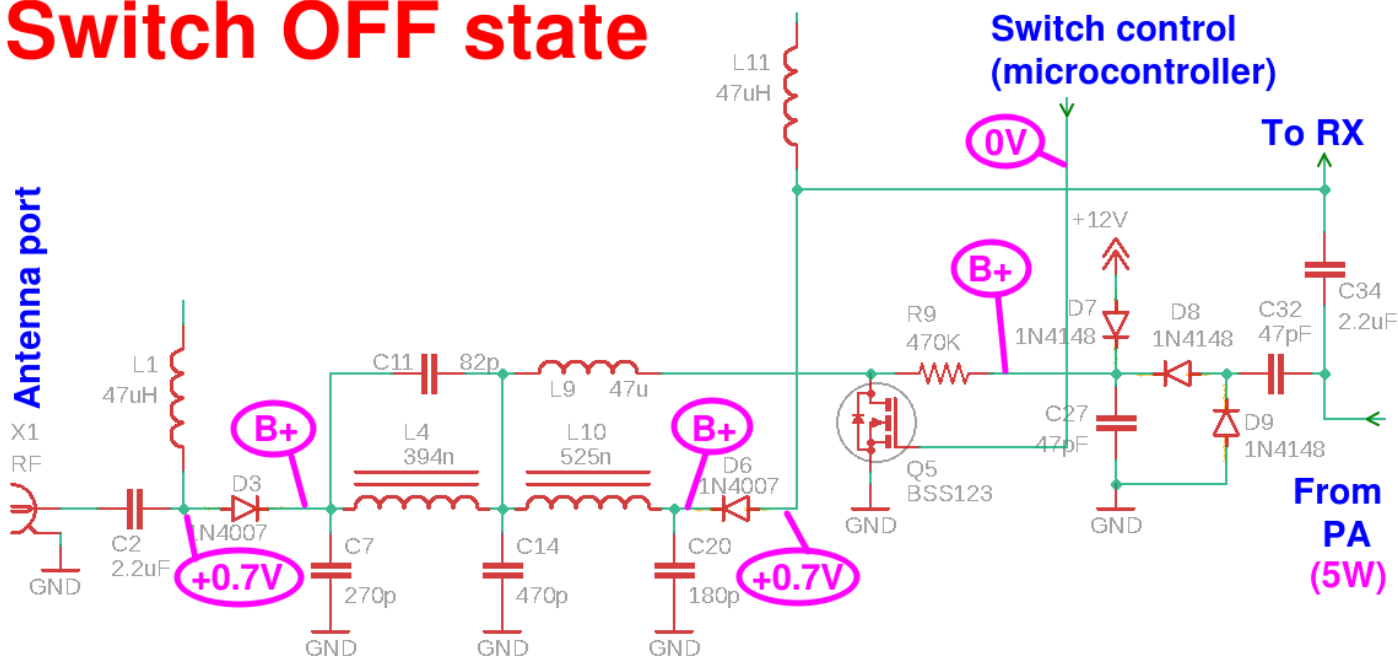

Remember the first rule of PIN diodes? "To switch a PIN diode off, apply a reverse voltage that is larger than the peak-to-peak voltage of the applied RF". Now, 5W of RF is 45V peak-to-peak (assuming 50-ohms impedance) and therefore we need more than this, as reverse bias, to switch off the diodes. Obviously this is not a voltage that is available from any supply rail! While Don W6JL had available 350V from the screen grid of the valves (tubes) in his transmitter – we have no such luxuries available here.

The very neat solution is to “borrow” a little energy from the PA output itself! Then voltage double and rectify it. The result is a nice clean DC which is always more than the peak-peak of the signal, and plenty enough to reverse bias the diodes so they are always perfectly and completely OFF.

This doubler section of the schematic is formed by D9, D8, C32 and C27. The resulting voltage, we shall call B+ in honour of valve (tube) circuits of old. Or HT if you prefer. It’s exact value will depend on the impedances and other factors but don’t worry, it is sufficient for the proper diode OFF condition.

Now this voltage passes through resistor R9, through inductor L9, and through inductors L4 and L10, right to the cathodes of diodes D3 and D6 respectively. The inductors don’t impede DC; resistor R9 would impede DC but the current involved is near zero so practically speaking there is no significant voltage drop across R9. The anodes of diodes D3 and D6 are at a potential of about +0.7 V. Why? Because whilst this Low Pass Filter is OFF, one of the other two LPFs is switched ON, and 38 mA current is flowing through each of its diodes, resulting in a voltage across the diodes of about 0.7 V.

So with B+ on the cathode and 0.7 V on the anode, the diodes see a large reverse bias voltages and satisfy the conditions for the diodes to be OFF. They present a high resistance to the RF, which cannot then flow through this Low Pass Filter. It is OFF.

The next thing to worry about is what happens when we are NOT transmitting. The signal during receive, still needs to pass through the proper Low Pass Filter for the band of operation. Its switches still need to be ON, and the other two LPFs OFF. Now there is no large 5 W (45 V peak-peak) signal to rectify and double to make a large B+ voltage. On the other hand, we also no longer need such a large B+ voltage, because now the Low Pass Filters (and their switches) are only seeing the small signals picked up by the antenna. To provide some voltage to reverse bias the PIN diodes, D7 connects +12V (the QDX supply voltage) to B+ during receive, when the doubler is not producing rectified RF (during transmit).

The other minor detail to consider, is that during Receive we aren’t handling anywhere near such a large amplitude signal so we don’t really need such a large current as 76 mA (total for two diodes) forward bias through the ON switches. A smaller current will suffice and will reduce the overall QDX receive current, making it more battery friendly.

Here’s the bias circuit used

BEFORE PCB Rev 4, that generates the appropriate forward bias currents.

When in receive mode, the TX signal from the microcontroller is at 0V; this keeps Q2 MOSFET switched off.

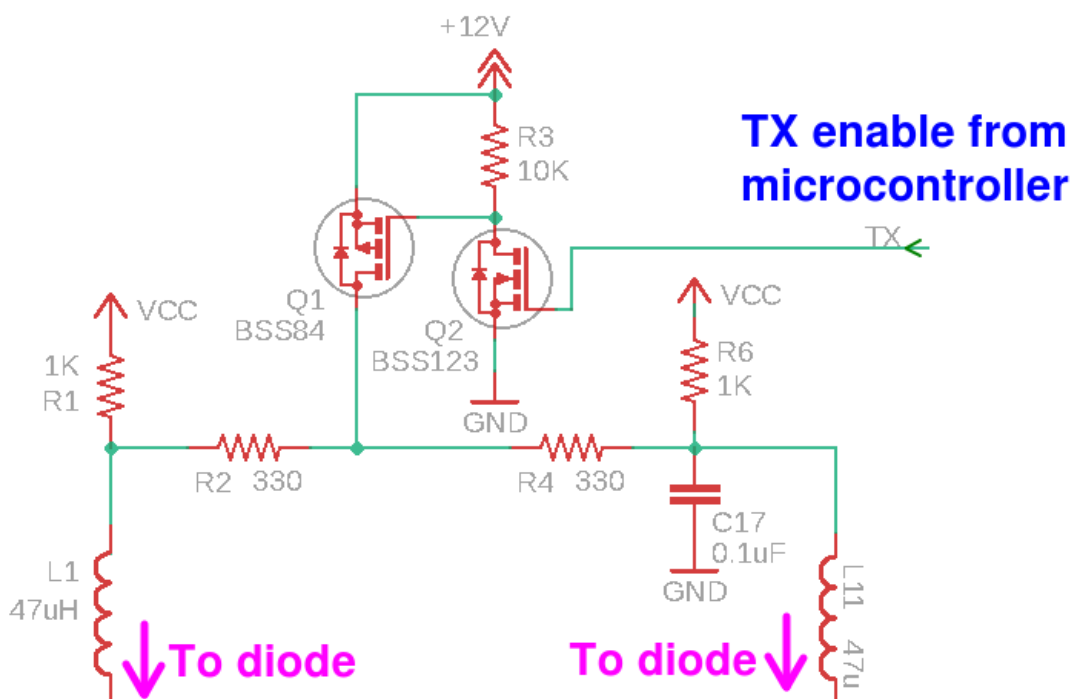

Q1 is a P-channel MOSFET and its gate is pulled to +12V when Q2 is off via 10K resistor R3, meaning that Q1 is also switched off.

In this configuration current flows from the Vcc supply rail (+5 V) through the 1 K resistors R1 and R6, and the inductors L1 and L11, to the respective two diodes. The current in each diode is given by Ohm's law $I = V / R$. The voltage across the resistor is 4.3 V because the voltage across the diode is 0.7V approximately. Therefore the current flow in each leg is $4.3 \text{ V} / 1000 \text{ ohms} = 0.0043 \text{ A}$, which is 4.3mA.

So in receive mode, the forward bias in each of two diodes in the ON Low Pass Filter, is 4.3mA for a total switch current of 8.6mA, which is not unreasonable.

When the TX signal from the microcontroller goes high, transistor Q2 switches on, pulling the gate of Q1 to near ground potential, thereby switching Q1 on. Now 12 V flows through Q1, and through each of R2 and R4, and on to the diodes. The current contribution through each resistor is given by Ohm's law $I = V / R$. The voltage across the resistor is approximately 11.3 V because the voltage across the diode is 0.7V approximately. Therefore the current flow in each leg is $11.3 \text{ V} / 330 \text{ ohms} = 0.0342 \text{ A}$, which is 34.2 mA. This sums with the current from the +5 V supply rail, to give a total of $34.2 \text{ mA} + 4.3 \text{ mA} = 38.5 \text{ mA}$.

So in summary, due to this biasing circuit:

- In Receive, total switch current is 8.6 mA approximately
- In Transmit, total switch current is 77 mA approximately

A new bias circuit for PCB Rev 4

The above mentioned transmit bias circuit worked however, it does suffer a problem: the power dissipation in each of the 330-ohm resistors (R2 and R4), when using a 12V supply, will be (in a simplified analysis) $0.038 \text{ A} * 11.3\text{V} = 429\text{mW}$. That's a large power dissipation in such a small (0603-size) SMD resistor, certainly exceeding its rating. The total effect of 858mW of additional power dissipation during transmit, is to cause significant temperature rise in that area of the board – under the output transformer – which may lead to an incorrect conclusion that the output transformer is running inefficiently and overheating.

A much better solution would be to use lower value resistors, and a much smaller voltage drop. For example, smaller resistors switched to the +5V rail, rather than 330-ohms to the +12V rail. That would work and resolve the resistor-out-of-spec problem, however really only moves the power dissipation from the resistors to the 78M05 voltage regulator. To really make the system more efficient would require a switched mode voltage regulator.

However, a switching regulator risks introducing noise into the sensitive receiver. To avoid this, the decision was taken in the Rev 4 PCB to use a 1.5V bias, using a switched mode regulator that is enabled only during Transmit. It therefore cannot interfere with the sensitive receiver.

A review of various commonly available inexpensive Switched mode regulator ICs was undertaken. A common characteristic is that the efficiency drops quite considerably when:

- 1) Low current loads are used (for example, below 100mA)
- 2) The voltage drop is a high ratio, such as 12V to 1.5V will be in this case.

Below are the efficiency curves for several common IC's reviewed. All of them exhibit this quite significant decline in efficiency.

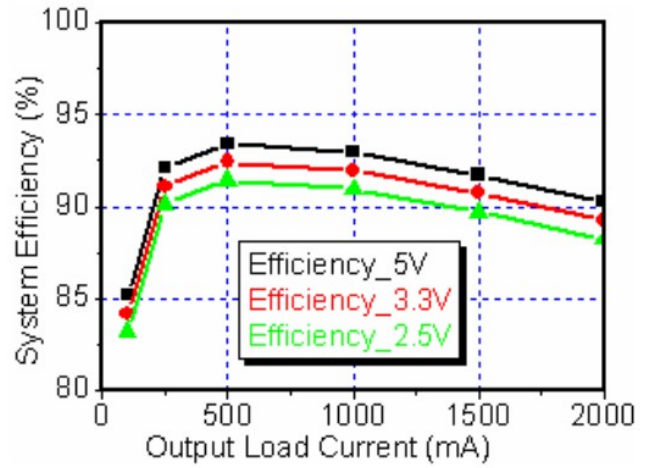
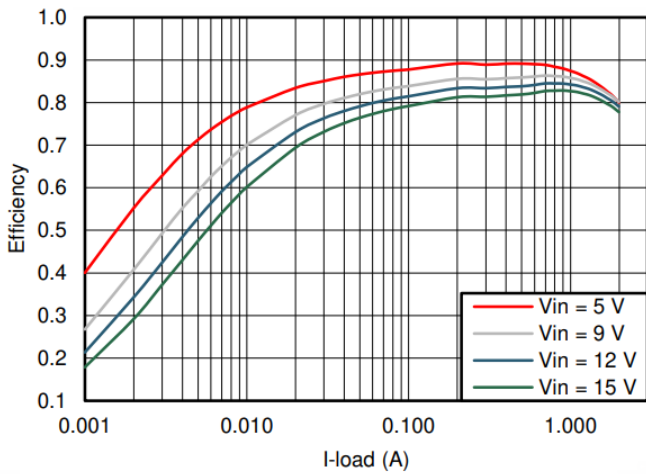

Figure 6-10. TPS562201 $V_{OUT} = 1.5\text{ V}$ Efficiency, $L = 2.2\ \mu\text{H}$

Figure 7. Efficiency vs. Load ($V_{in}=10\text{V}$)

Top left: TPS562201
 Top right: TD1410
 Bottom left: MP2315
 Bottom right: TPS562208

At first sight it's not terribly encouraging, due to efficiencies around 70%. However, when you examine the power savings it is possible to see that there will still be a massive saving in power dissipation; it is not necessary to get over 90% efficiency in order to achieve very substantial improvements in the system.

Given the current semiconductor shortage, which makes it quite unpredictable to obtain IC's at all, let alone at reasonable prices, and for the sake of the educational possibilities, I thought it would be fun to design a discrete component buck converter. I had also been inspired, some time ago, by coming across this well designed discrete 3.3V buck converter as shown at this link: <https://hw-by-design.blogspot.com/2018/08/vrm-discrete-33v-buck-converter.html>

I used the same concept for the pseudo push-pull switch transistor drive, but replaced the control loop with a firmware one. The STM32F401 as used in the QDX has plenty of spare unused I/O pins, one of which can be used to generate a PWM output, whose duty cycle is varied to achieve the desired output voltage; and one more as an Analog input to measure the output voltage and implement the control loop to regulate it at the target voltage.

The parts count to implement the buck converter circuit therefore becomes quite low. Using the microcontroller to form the control loop also has additional advantages; the SMPS can be easily shut down during receive operation when high current does not need to be pushed through the PIN switches; and the microcontroller is also able to choose the desired output voltage according to user configuration.

The actual circuit used is shown here (right).

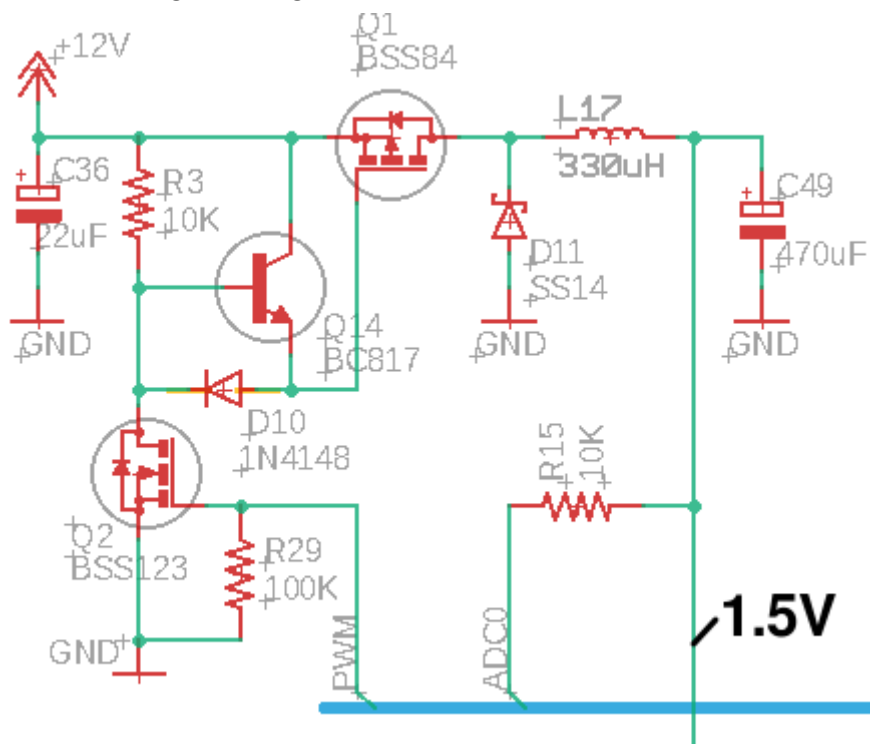

Q1 and Q2 were already part of the bias current switching circuit in the Rev 1-3 boards so the only additional components are the NPN transistor Q14, the schottky diode D11, inductor L17 and several resistors and capacitors.

1.5V is shown here as the output voltage but this is under control of the microcontroller; firmware version 1_05 and above must be used, and the voltage is set to achieve a bias current that is specified in the configuration screens (defaulting to 30mA).

Q1, D11, L17 and C49 form a quite conventional high-side switch layout common in buck converters. The more interesting aspect to this is the “pseudo push-pull” gate drive. I had to think about it for some time, to understand how this works.

When the PWM signal from the microcontroller goes high, Q2 is switched on, and this pulls the gate of Q1 low, switching on Q1 very quickly. This is the “pull”, which happens when the P-channel MOSFET Q1 (BSS84) is switched ON.

If that is as far as we took things, the buck converter would work, but it would have poor efficiency.

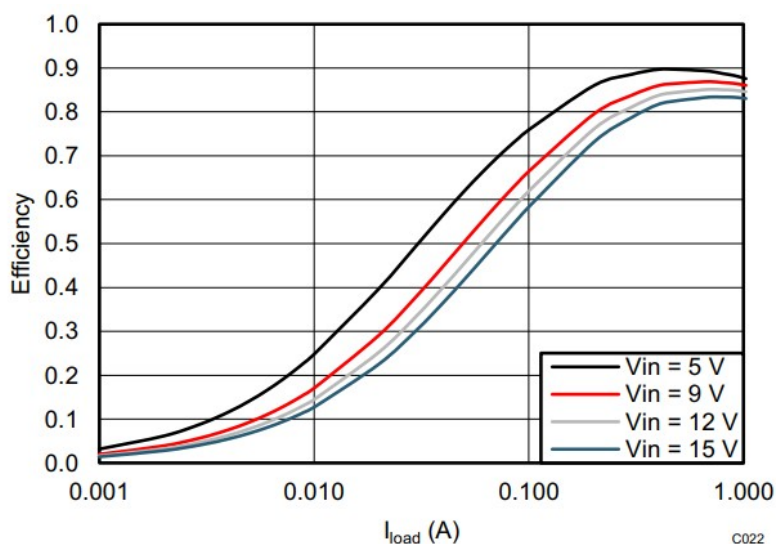
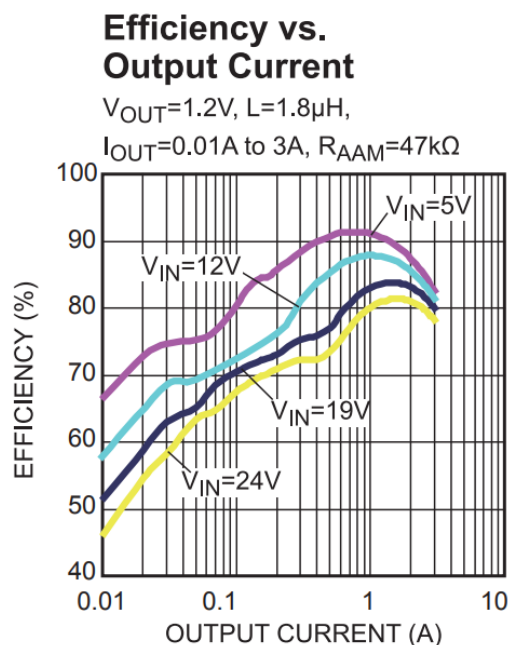

Figure 6-15. TPS562208 $V_{OUT} = 1.5 V$ Efficiency, $L = 2.2 \mu H$

The reason for this is that there is an effective gate-source capacitance which holds a gate charge on the MOSFET. When the Q2 switch is opened, removing the “pull”, the gate charge would dissipate relatively slowly through R3. The problem with a slow transition of the switch is that it is an opportunity for power loss. Ideally we want the switch to be saturated ON, with zero resistance. Zero switch resistance means zero voltage across the switch, and $P = I \times V$ with V being zero would mean no power loss. When the switch is saturated OFF, with ideally infinite resistance, then current would be zero and again, no power loss. The FASTER the switch transitions between the ON and OFF states, the less time will be spent wasting power in the non-ideal intermediate phase. This is why the slow switch-off wastes power, reducing conversion efficiency.

Adding Q14 solves this problem, it switches on and rapidly discharges the gate charge, causing Q1 to be switched off very quickly.

How this works, is interesting. Imagine the situation where Q1 is switched ON, because the PWM signal is high (3.3V), causing Q2 to be switched ON. D10's cathode is pulled to ground through Q2, and the voltage on Q2's anode is therefore something like 0.7V. This is plenty far below the Q1 P-channel MOSFET's source voltage, to turn on Q1 in saturation. At the same time, the base voltage of NPN transistor Q14 is at 0V, while its emitter is at +0.7V. The V_{be} voltage is therefore -0.7V; anything under +0.7V will ensure that Q14 is OFF, conducting no current.

Now as soon as the PWM signal goes low (0V), Q2 switches off, becoming a very high resistance. Q2 switches fast because the PWM output pin of the microcontroller is driving rail-to-rail with a low output impedance. Now the cathode of D10 is no longer pulled to ground. The anode of D10 (connected to Q1's gate) is still at 0.7, held there initially due to the gate charge on the Q1 MOSFET, hence D10 does not conduct and is effectively out of the circuit. Current flows from the +12V input through R3, and it can flow through the base-emitter junction of Q14 now that the emitter is effectively near ground.

Now with Q14 switched on, current passes through Q14 to discharge the Q1 switch MOSFET gate charge quickly. The current is limited only by the input current (through the 10K R3) multiplied by the hFE of the NPN Q14 transistor. It results in a quick discharge and switch off of the Q1 MOSFET, minimizing power loss in the on/off transition.

Q14 continues to conduct while base current can flow – which is to say, while the Vbe voltage is greater than 0.7. So it can discharge the Q1 gate capacitance right down to 0.7V from the +12V supply; by this time the gate voltage is well below the threshold voltage at which switching occurs. Then Q14 stops conducting and nothing more happens until the PWM signal goes high again, switching everything ON again.

This is why it's been called a “pseudo push-pull” drive. Really it pulls, and does not “push”; but it does “push” momentarily, enough to efficiently rapidly switch off Q1.

Various different inductors were tried during development, and switching frequencies in the range 12kHz to 900kHz. Low switching frequency harms efficiency because a large lossy inductor is required; very high switching frequency harms efficiency due to the power loss at each switch transition.

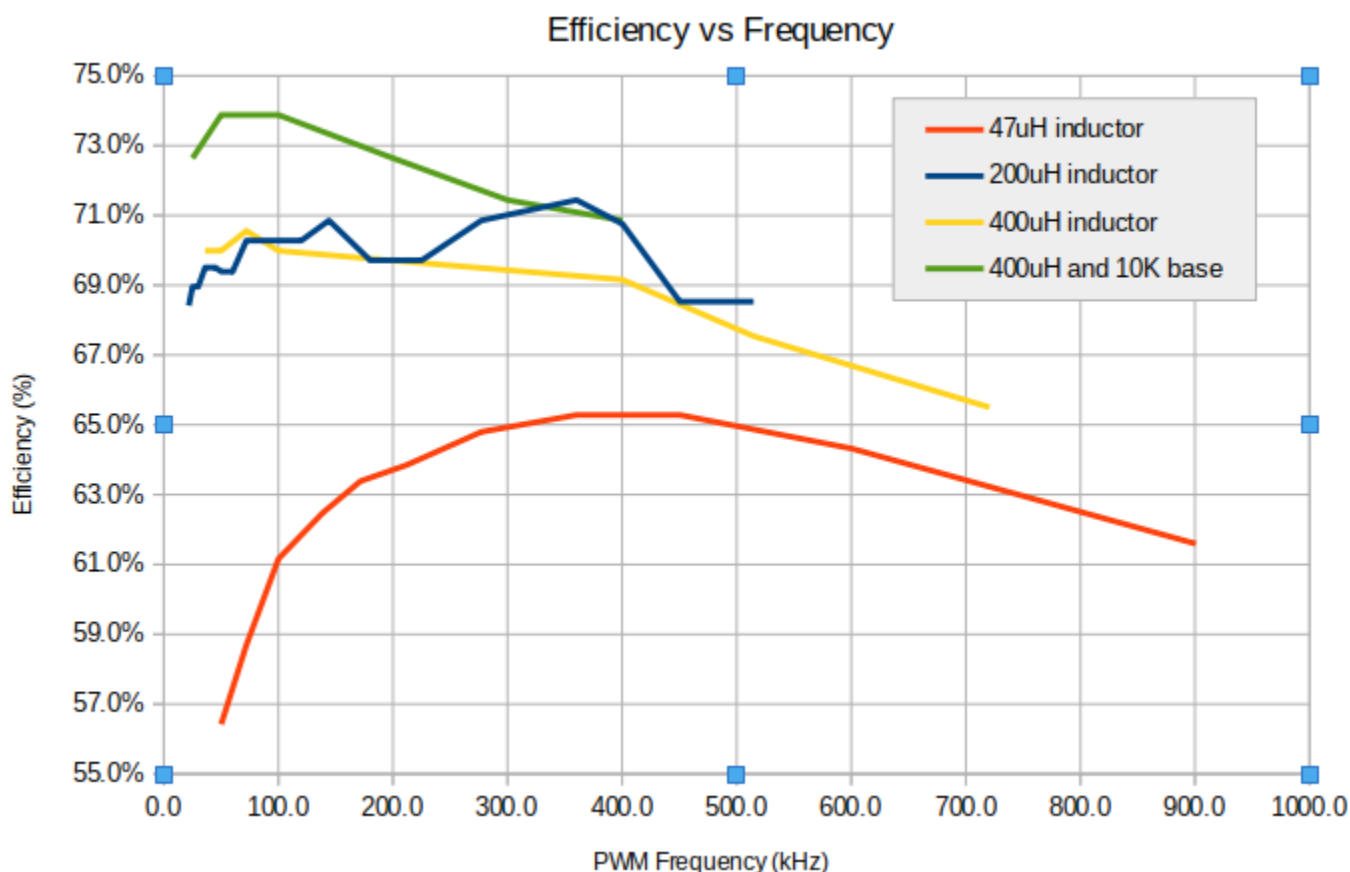

Well there are trade-offs everywhere, but fortunately it is not particularly critical. In the final implemented design, the inductor is 330uH and the switching occurs at approximately 100kHz.

The value of R3 also has an effect on efficiency. The lower R3 is, the more current will be available through Q14 to discharge the Q1 gate more rapidly on the On-to-Off transition. On the other hand, while the Q2 switch is ON, R3 is dissipating power, just wasting it; and this is minimized by using a large value for R3. The original circuit (see link above) used 2.2K but that circuit used a larger switching MOSFET and was designed for higher current loads. I found that again the value of R3 was not particularly critical but increasing it to 10K did gain a few percentage points of efficiency.

The plot of efficiency vs input voltage (right) shows the normal expected decrease in efficiency as the supply voltage is increased and the input-to-output voltage ratio is therefore increased.

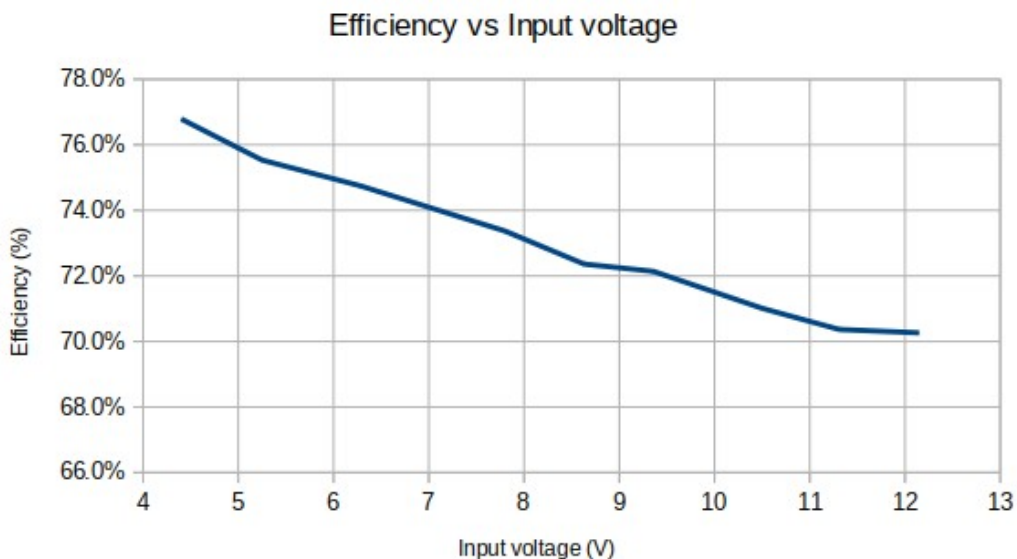

Before and after close-in spectrum analyzer sweeps were done and no interference observed from harmonics of the 100kHz switching frequency.

The harmonic attenuation was found to be several dB improved relative to the earlier circuit; I speculate that this is because the 470uF smoothing capacitor at the buck converter output further prevents the signal leakage path that exists past the low pass filters, through R2 and R4.

Performance

Analysis of the final Rev 4 manufactured PCB showed very satisfactory performance.

Firmware 1_05 and above must be used, as this firmware contains the control loop for the switched mode power supply (buck converter). In firmware 1_05 there is an additional "PIN fwd bias (mA) setting in the Band Configuration screen, allowing 5-60mA and defaulting to 30mA. This is used by the control loop to determine the necessary output voltage of the buck converter.

```

/dev/ttyACM0 - PuTTY
QDX v1_05_017
QRP Labs, 2022

+---Band configuration+-----+
| Band name (m)      | 80 | 60 | 40 | 30 | 20 | 0 |
| Audio gain (dB)   | 54 | 54 | 54 | 54 | 54 | 0 |
| Frequency min.    | 1400000 | 4000000 | 6000000 | 7500000 | 10500000 | 0 |
| Frequency center  | 3573000 | 5357000 | 7074000 | 10136000 | 14074000 | 0 |
| Frequency max.    | 4000000 | 6000000 | 7500000 | 10500000 | 14500000 | 0 |
| Sweep start       | 3200000 | 4000000 | 5000000 | 8000000 | 11000000 | 0 |
| Sweep step        | 20000 | 50000 | 50000 | 50000 | 100000 | 0 |
| BPF number (0-3) | 0 | 1 | 1 | 2 | 3 | 0 |
| LPF number (0-2) | 0 | 1 | 1 | 2 | 2 | 0 |
| PIN fwd bias (mA) | 30 | 30 | 28 | 30 | 30 | 30 |
| Transmit          | ENABLED | ENABLED | ENABLED | ENABLED | ENABLED | DISABLED |
| TX PTT +5V        | DISABLED | DISABLED | DISABLED | DISABLED | DISABLED | DISABLED |
| TX PTT grounded   | DISABLED | DISABLED | DISABLED | DISABLED | DISABLED | DISABLED |
| RX PTT +5V        | DISABLED | DISABLED | DISABLED | DISABLED | DISABLED | DISABLED |
| RX PTT grounded   | DISABLED | DISABLED | DISABLED | DISABLED | DISABLED | DISABLED |
+-----+-----+-----+-----+-----+-----+
|                               | Ctrl-Q = Quit |

```

The buck converter output voltage feeds current to the two PIN diodes via resistors R2 and R4, which are now 33-ohms. Along with the PIN diodes themselves (1N4007's in reality), the path to ground also contains two 47uH chokes, the toroidal inductors of the Low Pass Filter, and one of the BS170 switch transistors which switches on the desired LPF. The microcontroller must really strive to keep a constant current through the PIN diodes, as specified by the configuration

parameter in the Band Configuration screen. It must therefore do this by calculating the voltage drop across the 33-ohm resistors R2 and R4. However the voltage on the downstream side of R2 and R4 is not constant. It is NOT simply the relatively constant diode voltage drop; there is also a current-dependent voltage drop, due to the resistive component of the load, made up of the resistance of the two 47uH chokes, toroidal inductor, and BS170 drain-source “on” resistance.

Detailed measurements were undertaken to separate the fixed diode voltage drop and the current-dependent resistive drop (which actually also neatly includes the drop in diode voltage drop as the current changes!). A spreadsheet was used to plot the voltage vs current, and draw a linear line of best fit, determining parameters to use in the

microcontroller code. It is also necessary to include the current contribution from the 1K resistors R1 and R6, which feed current on both receive AND transmit from the +5V bus. This current contribution is in the region of 4mA but again, varies depending on the total current since the voltage drop has current dependence as per the above discussion.

There will indeed be some variation from device to device due to component tolerances but I am satisfied that the inaccuracy will be of no importance, the performance of the circuit is NOT marginal and does not depend on critical value of component choices.

Once all this was modeled in the firmware the actual bias current vs target bias current set in the Band Configuration screen was carefully measured and they were found to match very closely (the red and blue lines in the chart are practically indistinguishable).

Next after a range of detailed measurements on QDX units powered at 9V then at 12V, it became possible to calculate and plot several other graphs.

First is the efficiency, which is plotted (below right). The X-axis here represents the total current load on the SMPS, which is twice the PIN diode forward bias current since the total current is shared between two identical PIN diode circuits.

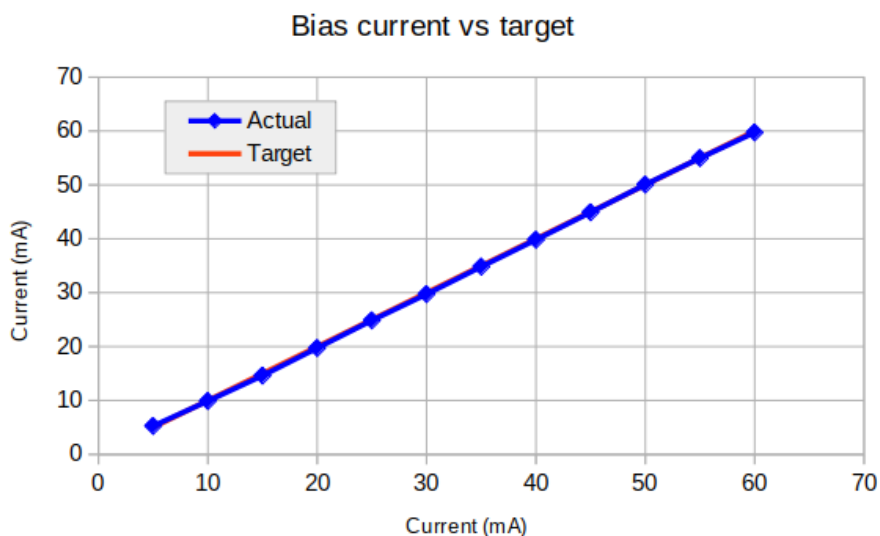
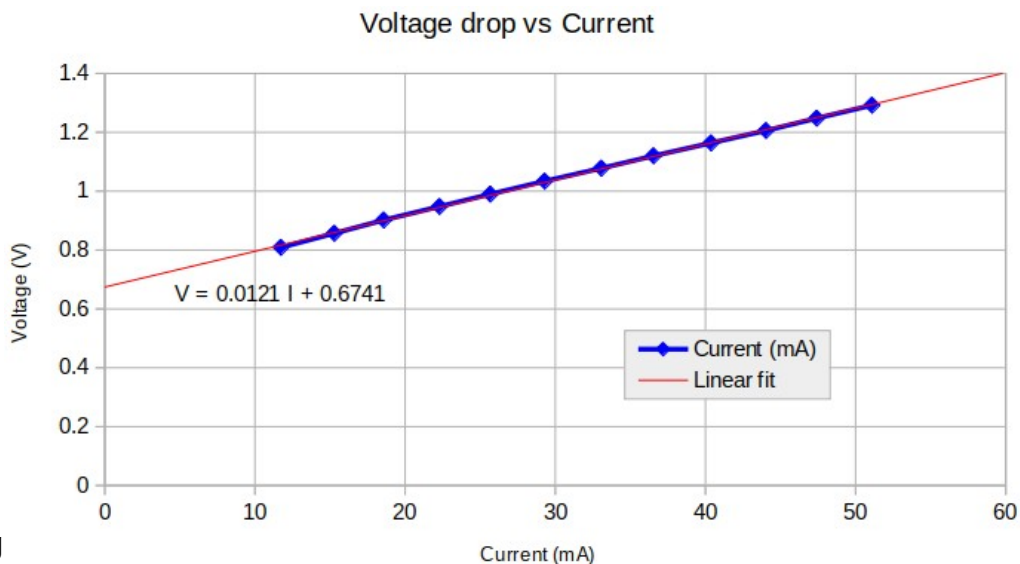

Typically we will choose a forward bias current around 30mA (which is the default setting in the Band Configuration screen). This means 60mA total load on the SMPS and the efficiency is found a little over 70%. This closely matches the values found during development and also approximates the efficiencies obtained at similar currents for several SMPS IC's studied.

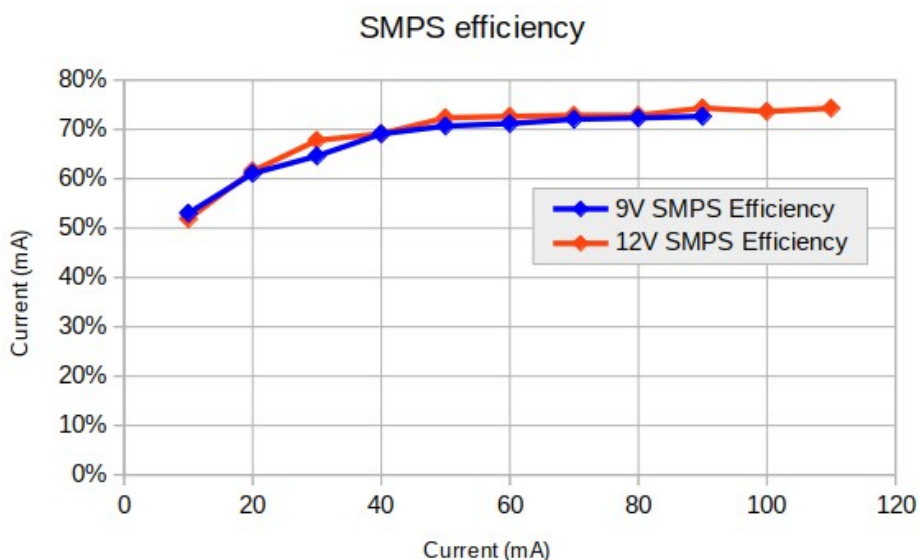

There follows a plot of the power dissipation vs bias current setting, for previous PCB revision QDXs (BLUE line) and now Rev 4 (RED line).

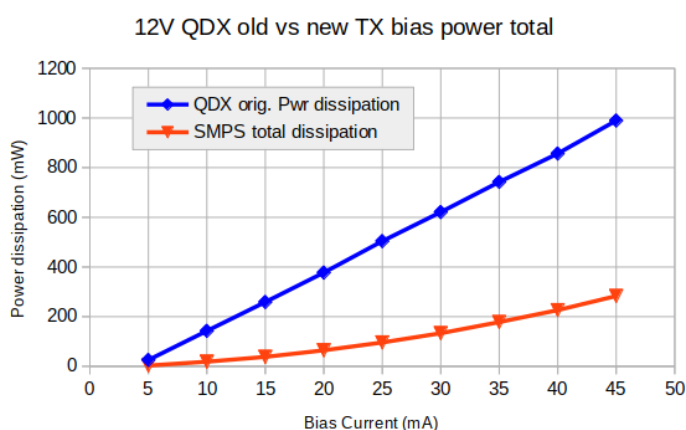
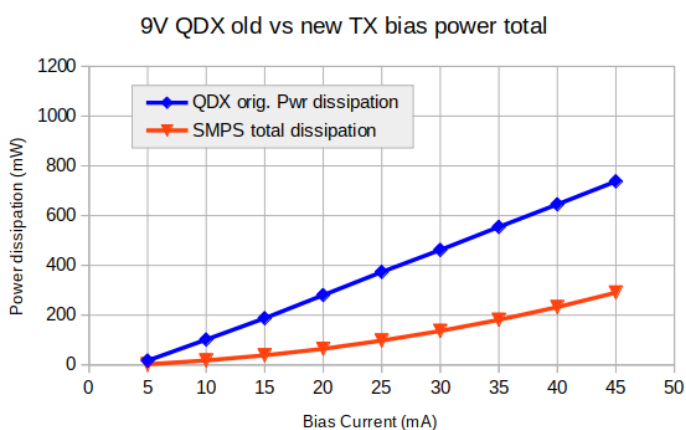

In reality on a previous PCB the bias current was not adjustable, it was fixed by the supply voltage and the value of resistors R2 and R4 (330-ohm). Since previous PCB revisions did not provide a decent constant current source, they merely provided forward bias current in a simple way via a resistor from +12V (switched on during transmit); the bias current was different depending on supply voltage. The value of R2 and R4 had to be chosen for the "worst case" and then some considerable safety margin, because very conceivably the QDX might be operated at lower supply voltages even than 9V.

On a 9V QDX, the bias current was about 30mA and on a 12V QDX, about 40mA. On the Rev 4 QDX we have effectively implemented this constant current bias supply control loop and so we can choose the lower value of 30mA. In fact, since we no longer need the safety margin (for operating voltages below 9V) we could go even lower, until the point where spectrum analysis shows harmonic performance deteriorates unacceptably, as diode distortion rises due to too-low forward bias current.

For the purposes of comparison the blue line is calculated, since the PIN diode voltage drop (including switching transistor and 47uH chokes etc) is known, and displayed as the blue line, rather than a fixed point at 40mA (12V) or 30mA (9V).

These charts show the total additional power dissipation in QDX during transmit, that is spent on the increased forward bias diode current necessary to switch 5W through the LPF without unacceptable distortion. They don't include the 4mA which is present continuously, even on receive.

Now it is possible to calculate a “before” and “after” power dissipation.

A 12V Rev1 to 3a board would run bias current per diode at about 40mA, resulting in a total additional Transmit heat dissipation of 856mW.

The Rev 4 board, run at 30mA (constant current) has a total additional Transmit heat dissipation of 134mW.

A massive saving of 722mW, almost ¾W of heating is now removed from the QDX enclosure!

Now let's examine the heat dissipation of each of the resistors R2 and R4:

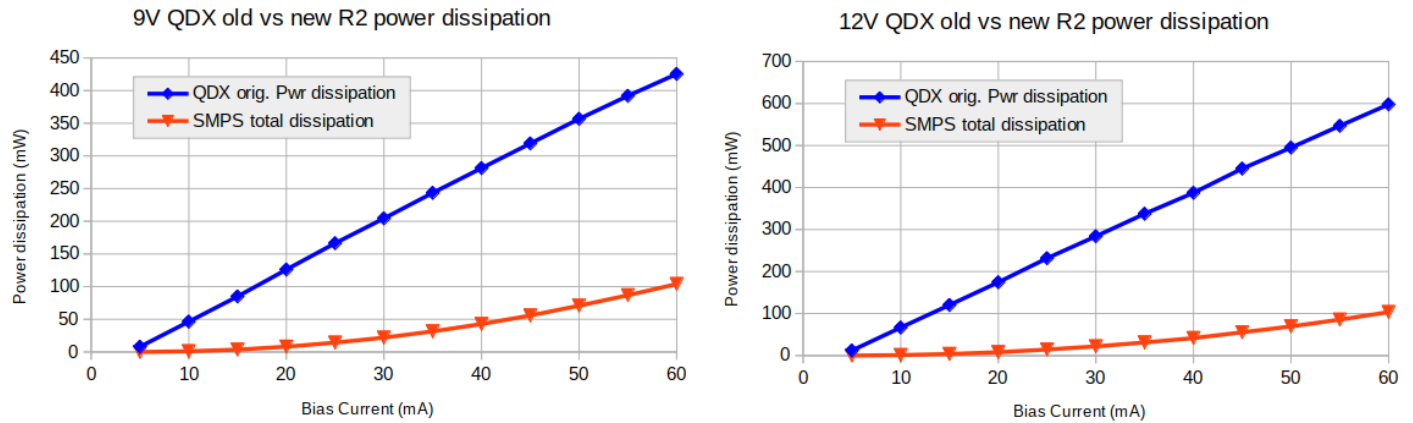

In a 12V QDX Rev 1 to 3a, according to the measurement data, R2 dissipates 387mW.

In a 12V QDX Rev 4 at 30mA constant current forward bias current, R2 dissipates just 22mW.

So we see a massive reduction in the heat dissipation in R2 and R4, which will definitely be within the specification of an 0603 sized resistor and will result in much lower temperature rise in the area of these components. This is exactly the desired result from this change to the bias circuit.

Since the SMPS will only be enabled during transmit, it is necessary to examine the performance of the SMPS as it is switched on/off on transmit/receive transitions.

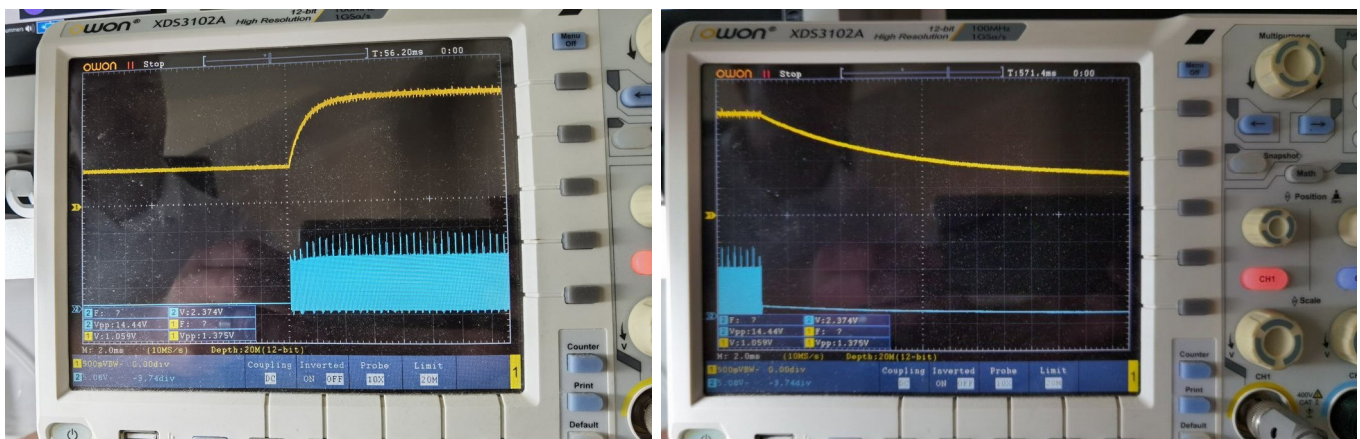

These two oscilloscope photographs show switch-on (left) and switch off (right). The top (yellow) trace has a vertical scale of 500mV/div and shows the SMPS output voltage. The lower (blue) trace is here connected to the Q1 drain at 5V/div. Since the horizontal scale is 2ms/div, very much too slow to show the 100kHz switching waveform, the blue trace just shows here as a solid block.

It is found that at switch-on, the SMPS reaches a stable desired output voltage in approximately 2ms, and the voltage decays in about 20ms at switch-off. There are no obnoxious spikes at the moment of switch on and switch off.

In this trace (right) the terminal application “Transmit Test” is used.

The yellow trace again shows the SMPS output at 500mV/div and the lower trace shows the Q1 drain again at 5/div. Horizontal scale is now 100ms/div.

A single T keypress causes a 0.5 second transmission burst. When operated from the TX Test screen, the RF burst starts almost immediately on the key-press.

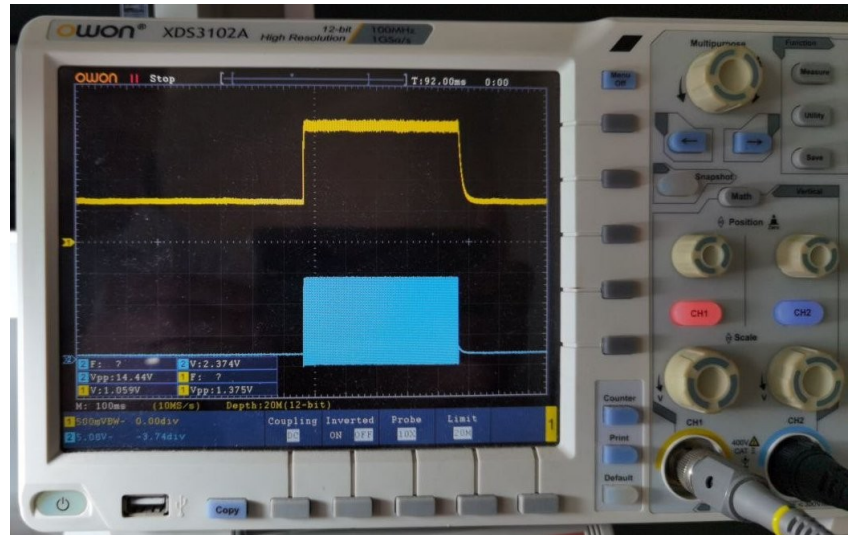

However, in a more practical scenario using WSJT-X, the result is as shown (right). In this photograph, WSJT-X’s “Tune” button is clicked on and off momentarily for a few seconds approximately.

The horizontal scale is 500ms/div and the blue channel is here connected to the RF output across a dummy load, at 10V/div. It is evident that the transmission from WSJT-X starts and ends significantly before and after the receive/transmit switchover, a time delay which dwarfs the 2ms rise time of the SMPS output voltage. In other words, the forward bias current is ready and waiting long before the RF arrives.

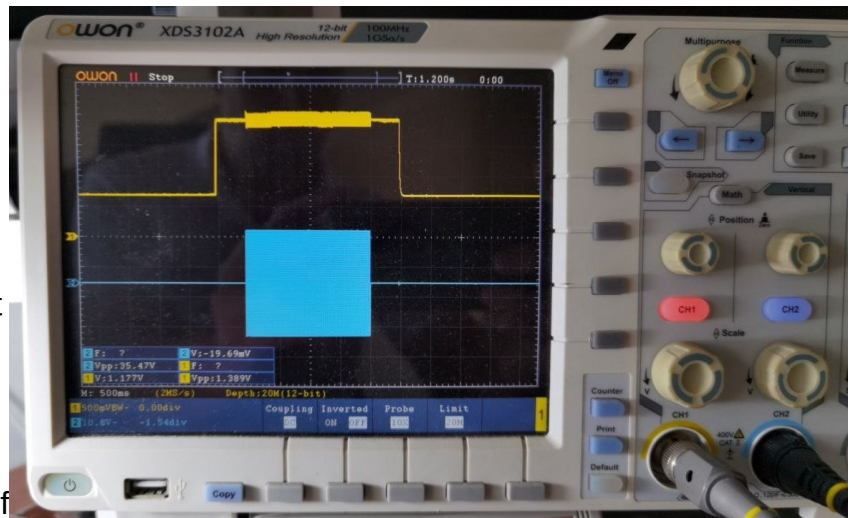

Overall it’s a very worthy modification to the QDX, providing substantial reduction in heating during transmit, and ensuring the R2 and R4 resistors are not operated out of specification.

To summarise:

- Constant current forward bias setting per band, configurable 5mA to 60mA (30mA default).
- Measured reduction in transmit heating in a 12V QDX, from 856mW to 134mW (722mW reduction, a factor of more than 6).
- Measured reduction in R2 and R4 dissipation from 387mW to 22mW, a 17-fold reduction.
- No impact on receive or transmit performance.

3.15 Configurable PTT (Push To Talk) output

The Rev 3 QDX PCB has a 3.5mm stereo jack as PTT output.

The “Tip” connection is pulled to ground during transmit, when Q13 is switched on by the microcontroller.

The “Ring” connection is pulled to +5V during transmit when Q12 is switched on by the microcontroller.

A common standard 3.5mm stereo audio cable with 3.5mm plugs at each end may be used without modification between the QDX and the QRP Labs 50W PA (which uses the positive-going +5V signal on the “ring” and makes no connection to “tip”).

During transmit, the microcontroller activates ONE of the PTT signals; you may configure which one, according to your needs.

It should be noted that:

- The QRP Labs 50W PA may not be used in high duty cycle modes such as FT8, JS8 etc at full power. It should be de-rated to half power operation at maximum, by using a 12V or 13.8V supply. Caution is advised.
- The 50W PA kit has a built-in Low Pass Filter and is designed for signal band operation only.
- Firmware 1.04 or above is required to use the PTT feature.

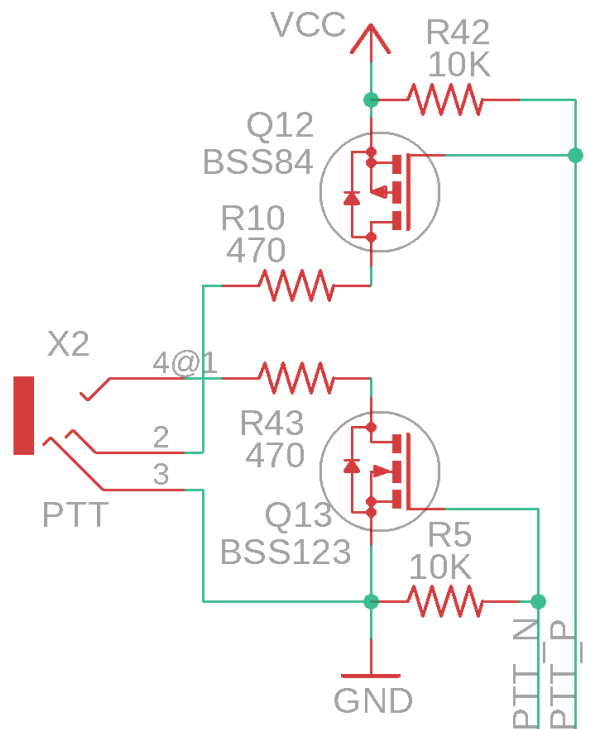

3.16 Voltage regulation and supply decoupling

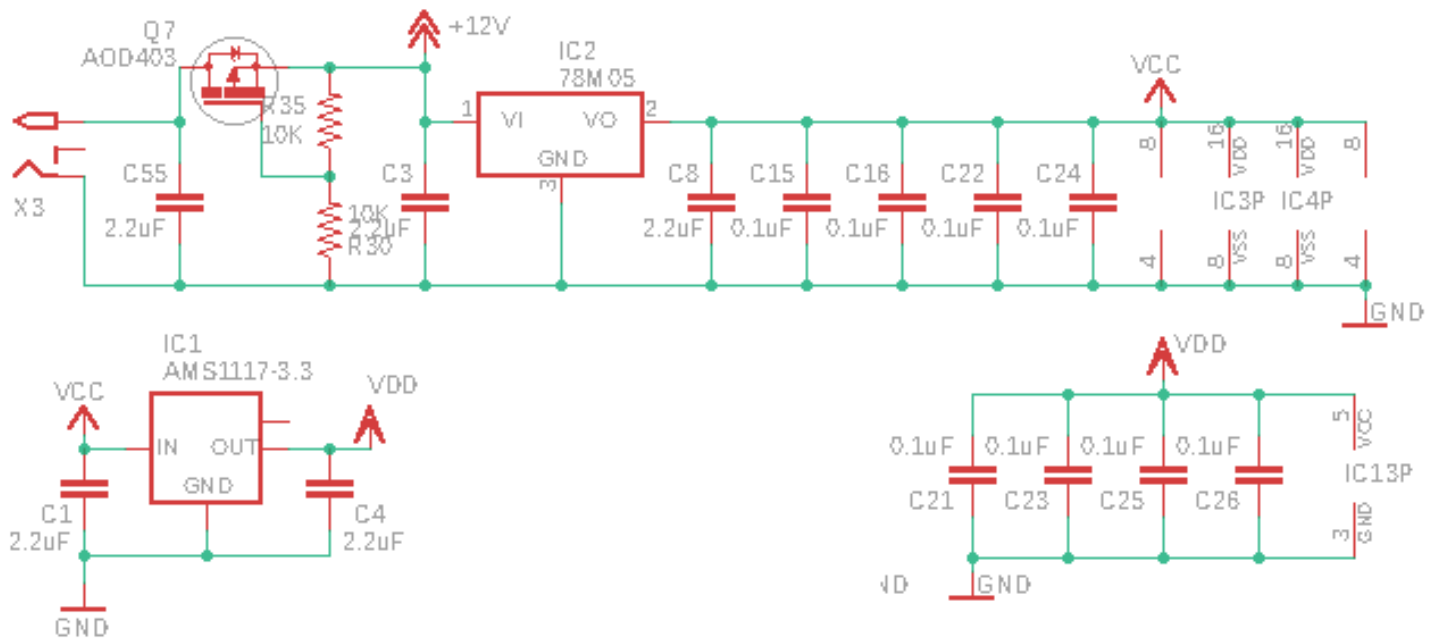

The two fixed voltage regulators in the QDX design produce +3.3V and +5.0V. The +5V voltage regulator type is 78M05 and the 3.3V type is AMS1117.

The 78M05 voltage regulator is robust, virtually indestructible. The AMS1117-3.3V regulator is a much more delicate IC, but in this application it is only regulating voltage down from +5V from the 78M05, so it is not being stressed and has a very low risk of failure. Note that this is a design change with respect to the Rev 1 QDX PCB where both voltage regulators were AMS1117, necessitating an additional 220µF capacitor at the power input; with the 78M05 used in Rev 2 and above, this 220µF capacitor is not needed.

PCB Rev 2 and above additionally have a reverse polarity protection feature provided by the P-Channel MOSFET type AO3407/AOD403. This transistor may appear, at first sight, to be connected “in reverse”, since the drain is connected to the incoming DC voltage from the DC connector, and the source is connected to the downstream circuits. However, it is in fact correct and necessary.

In normal operation, at power-up a little current will flow through the forward-biased “body diode” of the AO3407, raising the voltage at the source pin (on the right hand side of the transistor as drawn in the diagram). The gate is connected to half the supply voltage via R30/R35, hence the gate voltage is 6V (say) below the source voltage, and the transistor switches on, as desired. 2.2µF capacitor C55 provides smoothing for any small spikes that may be induced in the supply wiring or from the power supply.

If the operator should happen to accidentally connect QDX in reverse, then the gate-source voltage will be positive, which will ensure the P-channel MOSFET is switched OFF and no current flows through it. Since the transistor was connected “backwards”, if the voltage is applied in reverse, no current flows through the “body diode” either. It therefore achieves the desired reverse polarity protection function.

Despite the 4A continuous current rating being approximately 4x more than needed in the application, there were still reports of fried AO3407 MOSFETs; therefore for the Rev 4 PCB this MOSFET was changed to AOD403 which has a 15A continuous current rating, lower ON-resistance, and is packaged in a TO-252 style case that has a much higher heat dissipation capability. This should be more robust.

4 Performance measurements

Several QDX units have been measured; there are of course variations from one to another, due to component tolerances, toroid winding style, etc. The results presented here are for a sample QDX; all measured QDX were reasonably similar.

4.1 Receive current consumption

The following chart shows receive current vs supply voltage, per band. There is not much variation and it is fair to quote 100mA as the receive current. **For Rev 3 onward, 150mA is normal.**

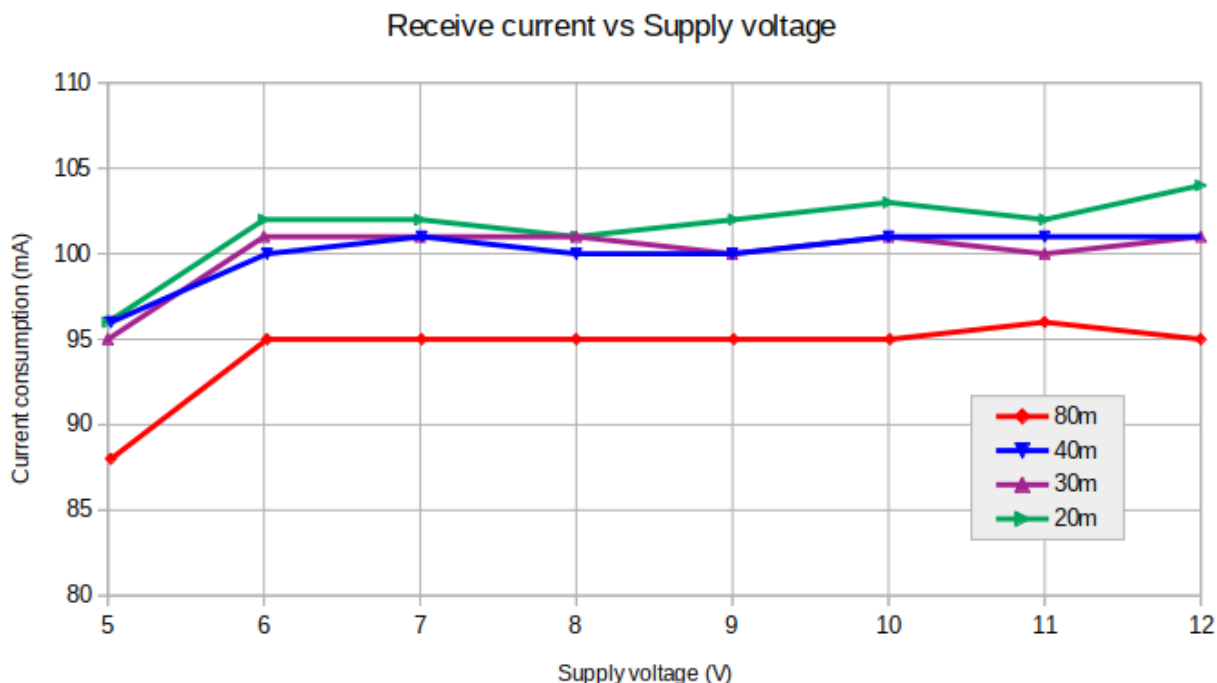

4.2 Transmit current consumption

The following chart shows transmit current vs supply voltage, per band.

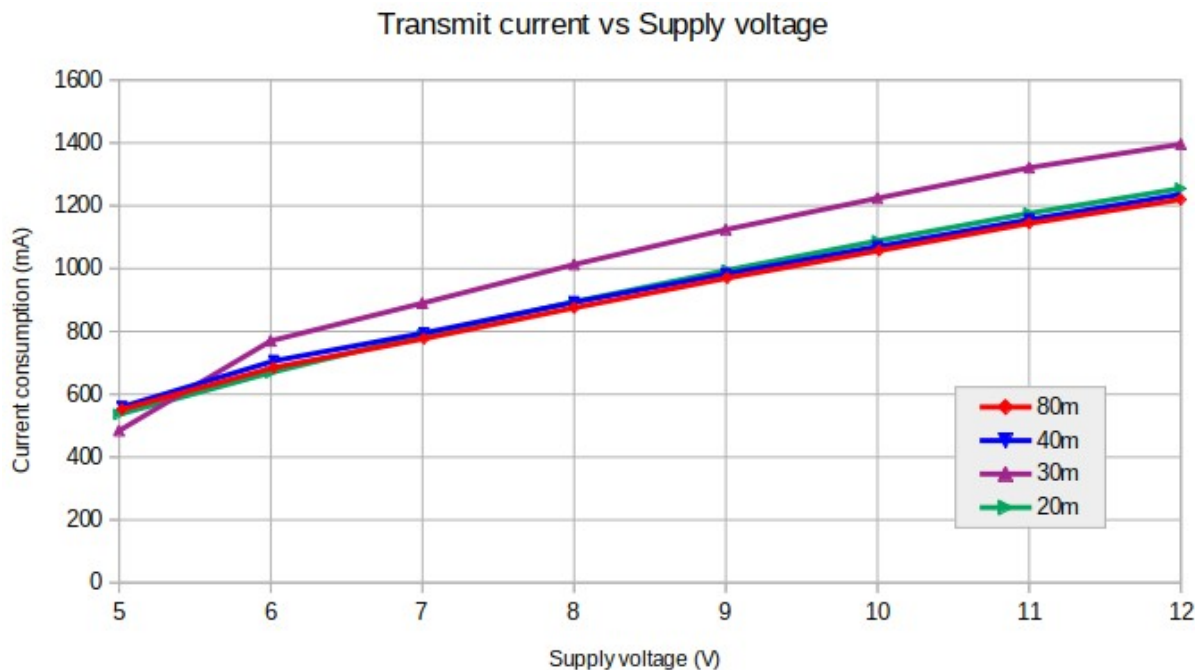

4.3 Power output vs supply voltage

Power output is consistent across bands. **Operation at more than 6W output is NOT RECOMMENDED and may destroy the power amplifier transistors.**

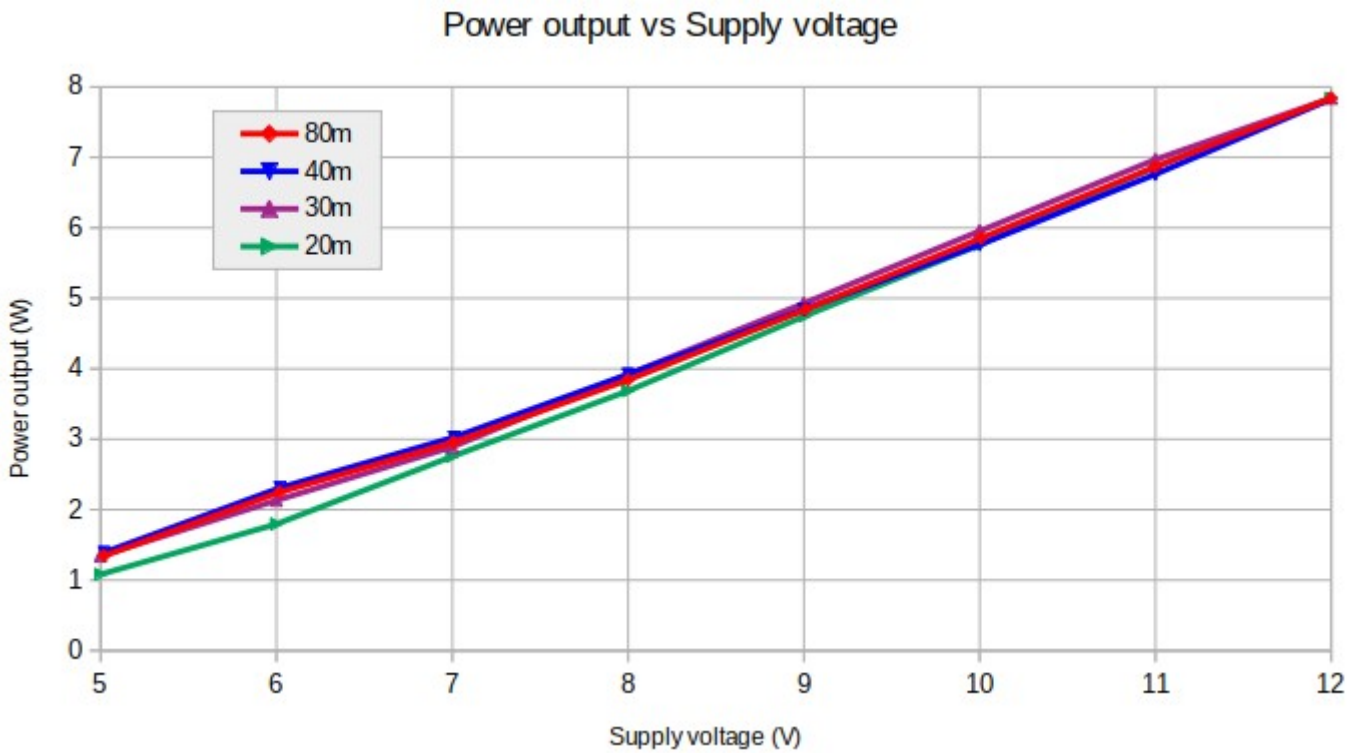

The following graph shows power output vs supply voltage for 40m operation, with the two alternative output transformer winding arrangements. 3:2 is less efficient but more suitable if you need to operate from a 12 – 13 V supply.

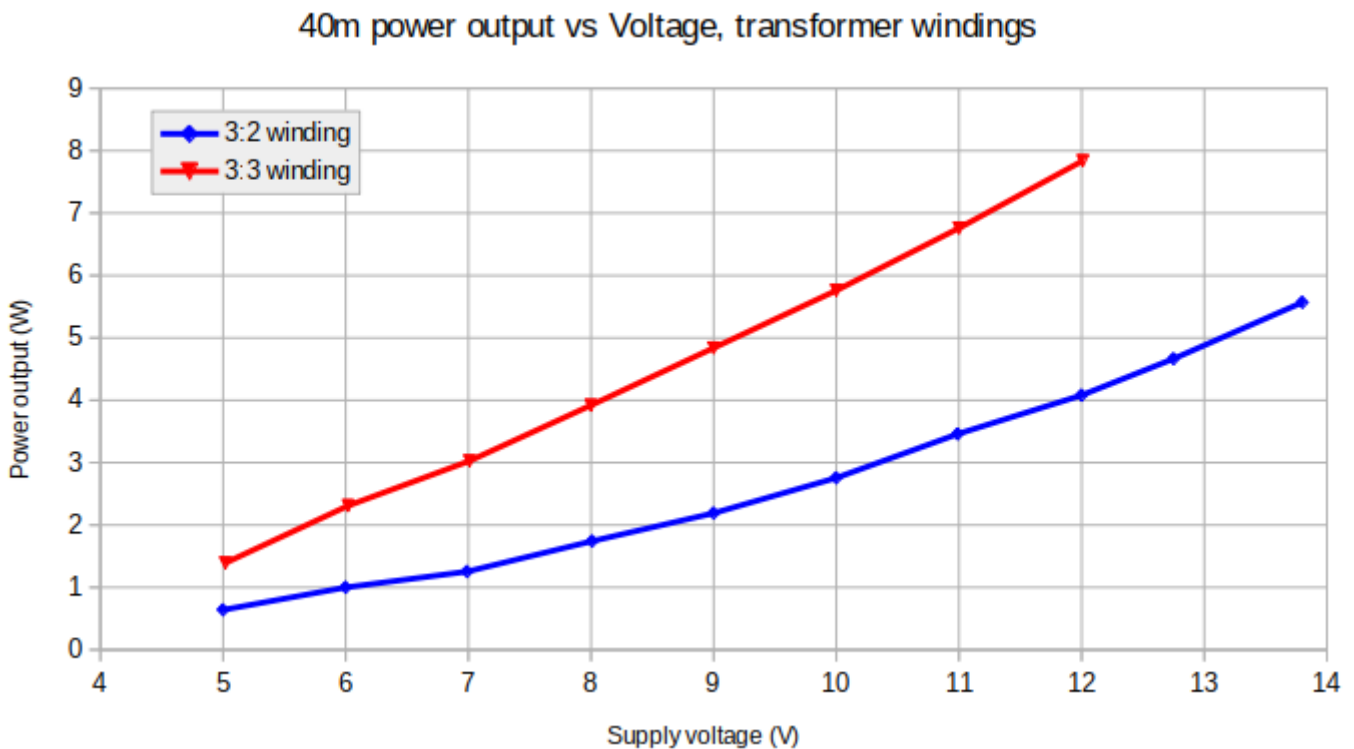

4.4 Output harmonic content

Equipment:

QDX > QRP Labs 50-ohm dummy load kit > attenuator > Advantest R3361C Spectrum Analyzer.

Band	80m	40m	30m	20m
2 nd harmonic	-53 dBc	-55 dBc	-43 dBc	-55 dBc
3 rd harmonic	-64 dBc	-71 dBc	-56 dBc	-57 dBc
4 th harmonic	-70 dBc	Undetectable	Undetectable	-70 dBc
5 th harmonic	-70 dBc	-73 dBc	-62 dBc	Undetectable

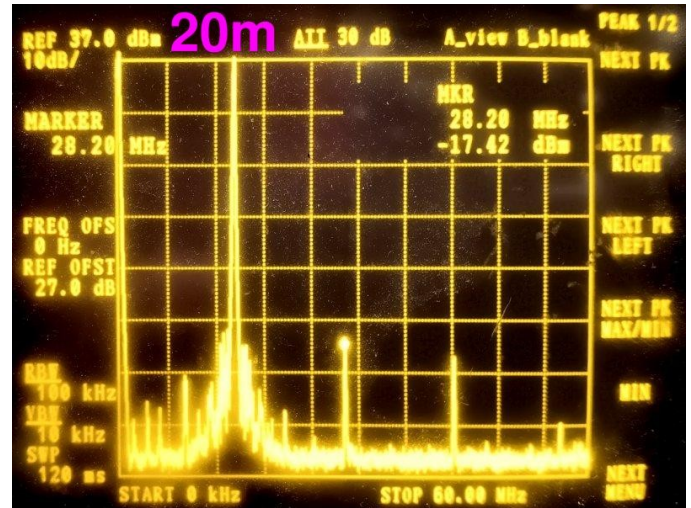
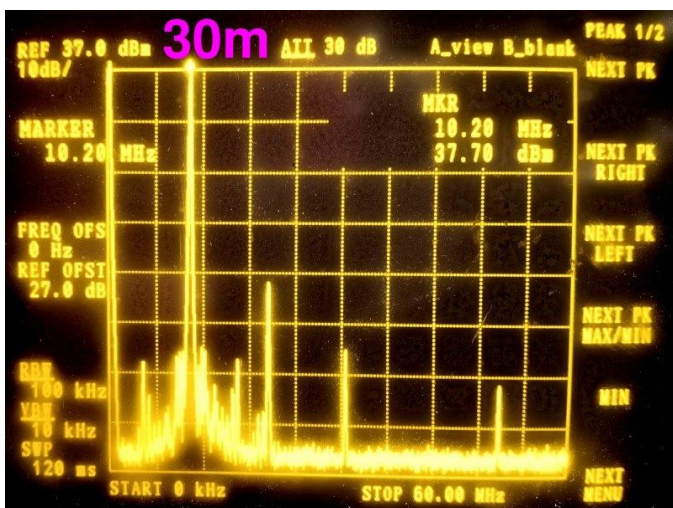
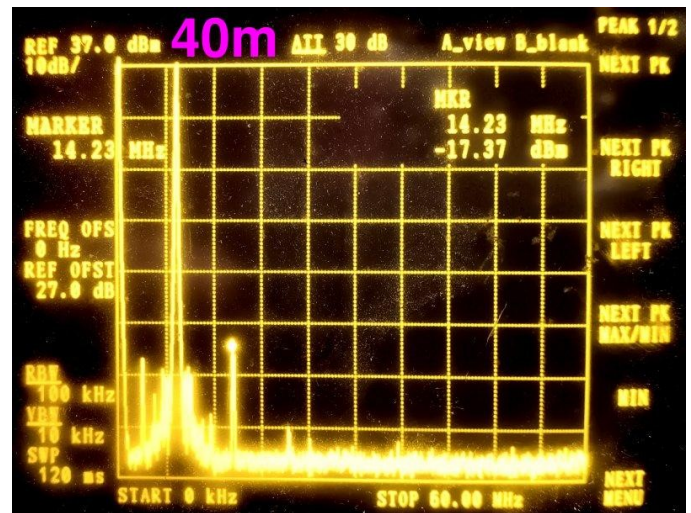
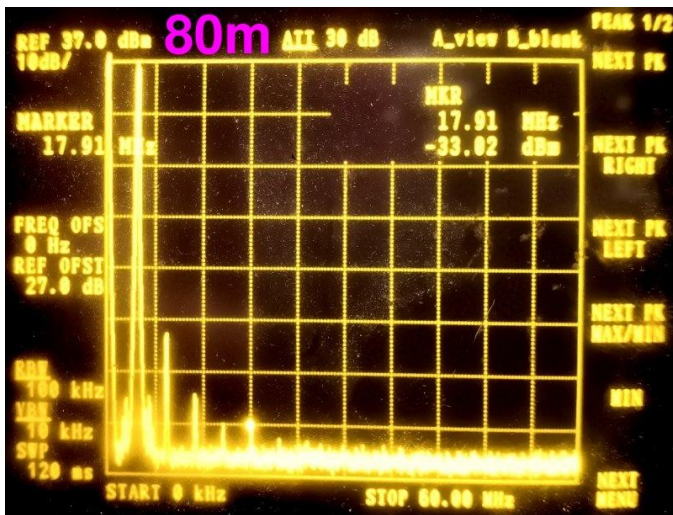

4.5 Unwanted sideband suppression

Measured using the QDX's internal signal generator; unwanted sideband is 60-70 dB down.

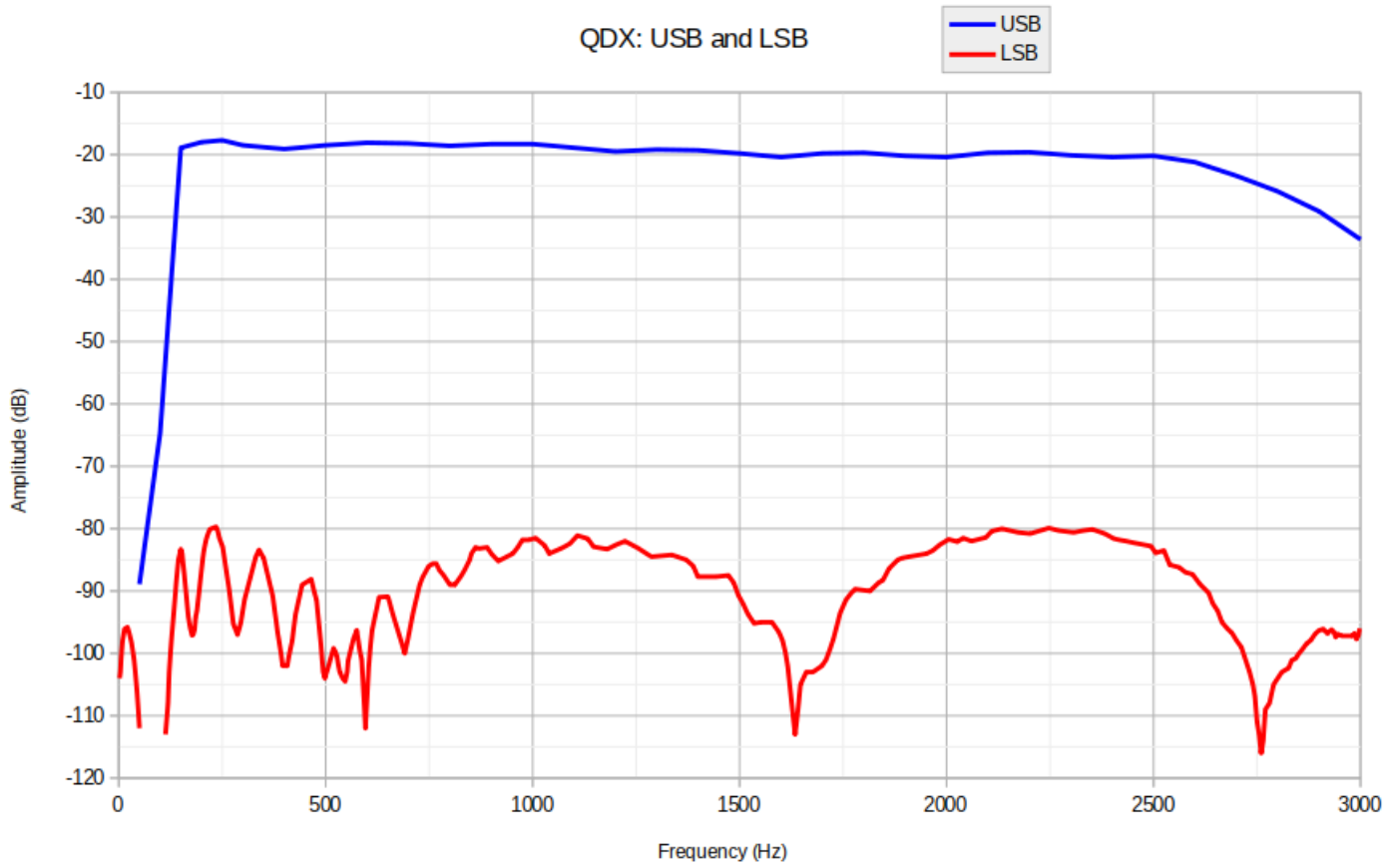

This is also seen on the QDX's own terminal application, Audio sweep tool:

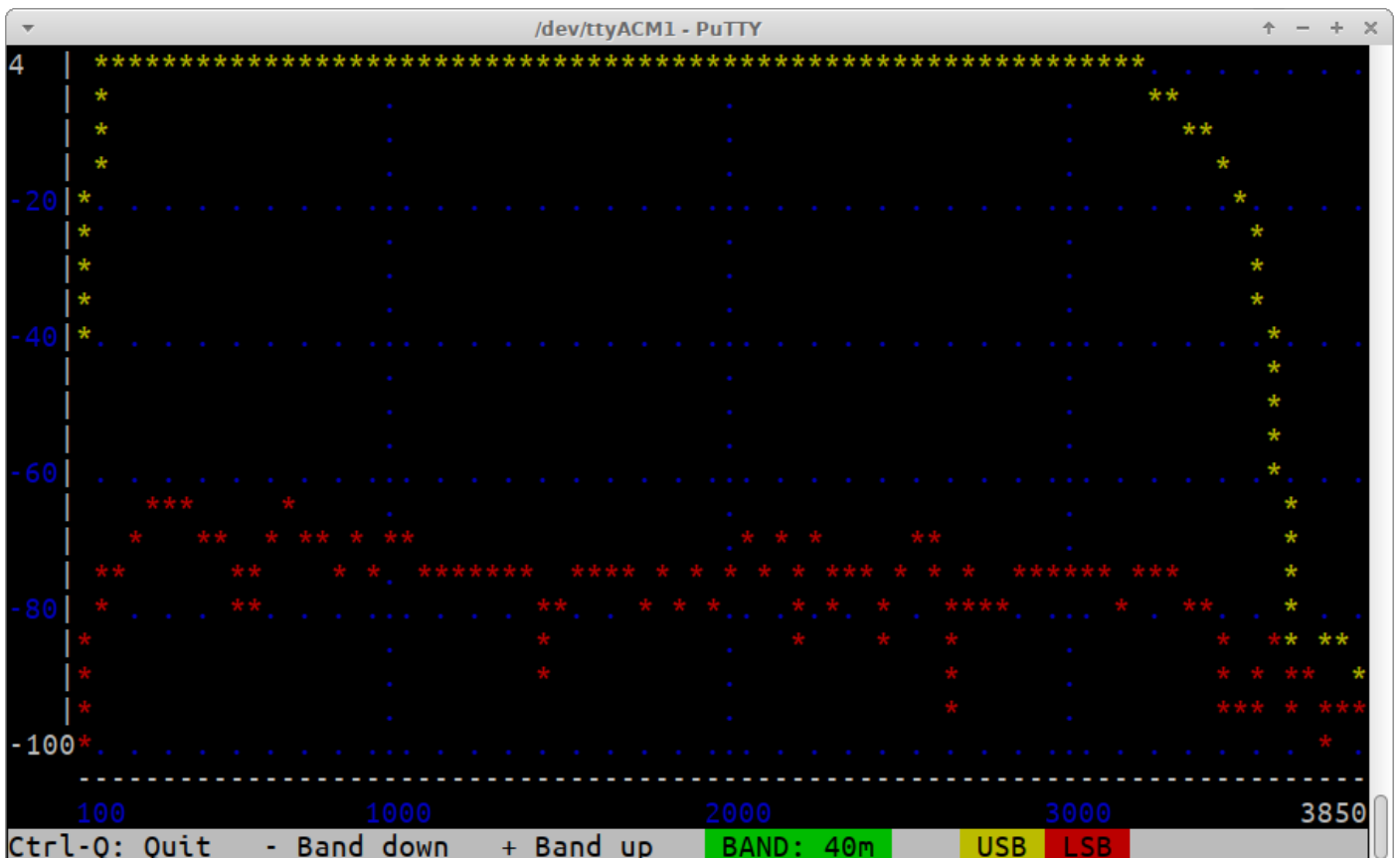

5. Resources

- For updates and tips relating to this kit please visit the QRP Labs QDX kit page <http://qrp-labs.com/qdx>
- For any questions regarding the assembly and operation of this kit please join the QRP Labs group, see <http://qrp-labs.com/group> for details

6. Document Revision History

1.00	09-Oct-2021	First draft version version 1.00
1.01	27-Oct-2021	Lots of corrections; and update for firmware 1.01
1.02	27-Oct-2021	Added note about IQ Mode not being applicable to WSJT-X and digi modes software; and that firmware update files downloaded from the QRP Labs website need to be unzipped before installation
1.03	28-Oct-2021	Added 0.33mm wire specification to sections 2.11 and 2.12
1.04	28-Oct-2021	Clarified T1 diagram 3:3 for 9V operation; and added notes to the text about remembering to wind 2 turns secondary for 12V operation.
1.05	08-Nov-2021	Minor typos corrected
1.06	10-Nov-2021	Added recommended comms port settings for Windows, which seem to make CAT communications more reliable according to some user reports.
1.07	23-Dec-2021	Revised for PCB Rev 2
1.08	29-Dec-2021	Corrected error in section 2.12, continuity checks on trifilar transformer
1.09	03-Jan-2022	Corrections to page 24 diagram, removed R34 reference, and typo on page 17 (thanks Dave M0JTS for pointing these out)
1.10	06-Jan-2022	Re-format only to correct some formatting problems
1.11	07-May-2022	Revised for PCB Rev 3
1.11a	27-Jul-2022	Corrected typo, Q7 in parts list is AO3407 (4307 was wrong)
1.12	03-Aug-2022	Revised for PCB Rev 3a (section 2.3a particularly, and no need for the insulating tape at section 2.15)
1.13	15-Sep-2022	Corrected typo, inductors are axial not radial (thanks David KC3AWJ)
1.14	30-Sep-2022	Revised for PCB Rev 4
1.15	19-Oct-2022	
1.16	23-Dec-2022	Revised for high-bands QDX version
1.17	30-Dec-2022	Revised for PCB Rev 5
1.18	09-Jan-2023	Fix typo on page 31
1.18a	07-Feb-2023	Fix 0.3mm wire length for 20-10m version in parts list

1.18b	15-Feb-2023	Added comment about D1/L3 connection in section 2.6
1.18c	20-Feb-2023	Section 2.9 typo on number of turns for longest part of winding for high bands version
1.18d	24-Feb-2023	Corrected footer
1.18e	01-Apr-2023	Added page for T37-17 version of high bands QDX
1.18f	04-Apr-2023	Corrected colour description of toroid paint, on page 32
1.19	12-Sep-2023	Moved output transformer construction to a separate document
1.20	05-Jun-2024	Corrected typo on page 30 (#228 wire should be #28 wire)